



FILE/80
Owner's Manual

HP-86/87

May 1983

82824-90001

Revision B FILE/80 Software

The discs shipped with this manual contain revision B of FILE/80 software. Revision B is the new international version of FILE/80. These capabilities are only offered with revision B FILE/80 software:

- User entry of a multi-character currency sign during file creation. The maximum length is four characters.
- Choice of unique or non-unique primary keys.
- Use of **(LIST)** and **(PLST)** keys to print any record or group of records accessed with a search.

Any files created with earlier versions of FILE/80 can be used with revision B software. Note that revision B files can be accessed with earlier versions only if they have a one-character currency sign and a unique primary key.

Table of Contents

Overview	6
Terms You Will Encounter	7
File Management—A Perspective	10
Using This Manual	11
The FILE/80 Display	12
Hard-Copy Output	13
Section 1: Getting Started	19
Introduction	19
Loading FILE/80	20
Demonstration of FILE/80	21
Section 2: Creating Master Forms	29
Introduction	29
Starting Forms Creation	30
File Names and Passwords	31
File Configuration	31
Entering Peripherals	33
The Master Form	35
Fields	36
Entering Field Names	37
Field Types	39
The Character Type	40
The Integer Type	40
The Float Type	41
The Currency Type	41
The Autodate Type	42
The Date Type	42
Field Lengths	43
Putting Fields	45
Formatted Character Fields	46
Insertion Characters	47
Moving Fields	48
Deleting Fields	49
Text	49
Key Selection	49
The Primary Key	50
Secondary Keys	51
Designating Keys	51
File Size	53
Section 3: Accessing Your Records	59
Introduction	59
File Access	59
File Name and Password	60
Verifying Peripherals	60
Adding Records	62
Instructions for Using CTRL	63
How to Use BTCT	64
Setting Defaults	64
Setting Tabs	65
Record Access	67
Locating File Records	68
Finding Records With Relation	70

Use of INCL	73
Multiple Search Conditions	74
Finding Records With Range	75
Finding Records With QUERY CUR	76
Finding Records With REPORT	78
Alternate Search Conditions	79
Updating File Records	80
Deleting File Records	84
SEARCH Screen Summary	86
Section 4: Generating Reports	91
Introduction	91
Report Definition	92
Report Layout	97
Report Fields	98
Picking Fields	98
Putting Fields	99
Computed Fields	101
Moving Fields	103
Deleting Fields	104
Entering Text	104
Headings, Body, and Footings	104
Ordering Your Report	107
Designating Break Types	109
Sort Fields, Breaks, and Subtotals	112
Report Trends	112
Storing Reports	115
Printing Reports	115
Report Defaults	117
Printing With the REPORT Screen	119
Changing Reports	122
Section 5: Generating Letters	127
Introduction	127
Letter Definition	128
Letter Layout	130
Text	132
Fields	133
Moving Fields	135
Deleting Fields	136
Ordering Letters	138
Printing Letters	140
Defaults	141
The LETTER Screen	143
Section 6: Printing Labels	149
Introduction	149
Defining Labels	151
Entering Dimensions	152
Label Layout	153
Text	154
Fields	155
How to Date Your Labels	157
How to Specify Printing Order	158
Storing Label Output Formats	158
Printing Your Labels	159
Setting Defaults	159
Choosing Records	161
How to Print Labels	161
Changing Labels	163
How to Change Text	164
How to Move Fields	164
How to Delete Fields	164

Section 7: Changing Master Forms	167
Introduction	167
Instructions	167
How to Change Text	171
How to Add Fields	171
Moving Fields	172
How to Delete Fields	173
Changing Fields	173
Changing Keys	175
Output Formats	177
How to Change File Size	177
Choosing File Size	178
Section 8: Mass Storage Commands	183
Section 9: File Backup	187
Introduction	187
Use of File Names	187
Making Backup Files	189
Using Backup Files	190
Section 10: File Recovery	193
How to Recover Files	193
Appendix A: FILE/80 Screen-Special Function Key Summary	195
Appendix B: Sorting	211
Appendix C: Default Printer Types	213
Appendix D: Hard Disc Usage	215
Index	217

Overview

FILE/80 is a file management system that is designed for the HP-86 and HP-87 computer systems. By utilizing the special function key capability of these Hewlett-Packard computers, FILE/80 becomes a friendly and responsive software solution. FILE/80 is also a powerful tool providing the user with a variety of file management operations.

From engineering to financial analysis, FILE/80 supports a broad range of applications. You can keep track of orders, sales, inventory, and a host of other items with FILE/80. If you have an application where you need to organize, examine, and modify information, then FILE/80 is the tool for you.

Two fundamental concepts of FILE/80 are **file** and **record**. A record is a collection of related data. For example, all the information about a customer constitutes a record. A file is a collection of records. All of the customer records for a company would comprise a file.

The following diagram graphically illustrates the concepts of **file** and **record**:

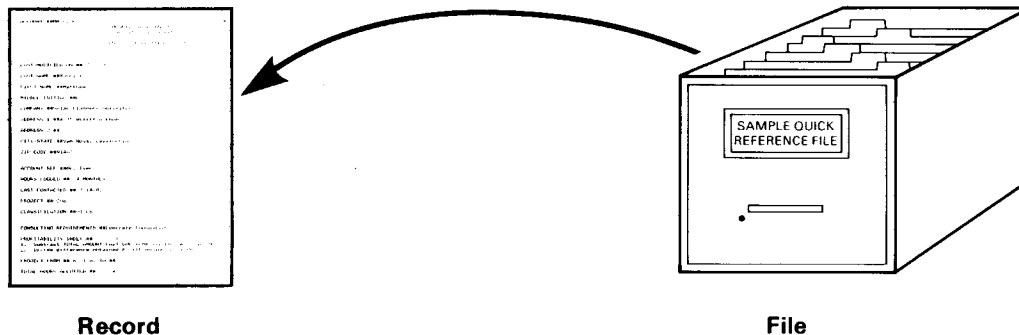

Some of the many features of FILE/80 include:

Forms—FILE/80 lets you tailor the appearance of records to match your application.

Searching—FILE/80 gives you the ability to search for either a specific record or for a number of records meeting specific criteria.

Sorting—records can be output in a variety of ordered sequences.

Output—FILE/80 can print reports, letters, or labels based upon information stored on file records.

With FILE/80, you don't have to be concerned with how records are stored to access them. The system does all the bookkeeping involved with entering and storing records in the correct locations. The ability to

automatically handle the placement of records into a file makes FILE/80 a powerful tool in managing your application.

The special function keys and screens utilized by FILE/80 guide you through each phase of file management. Whatever your application, there are three steps that apply to file management applications.

- a. **CREATE:** Define and design the master form onto which data will be recorded. Once completed, a form with data becomes a record.
- b. **QUERY:** Examine or update the individual records in your file.
- c. **OUTPUT:** Choose which records will be accessed and use them to produce reports, letters, or labels.

By combining the familiarity of a conventional filing system with the capabilities of the computer, FILE/80 offers you a system that is both easy to use and flexible. In addition to the FILE/80 Program Discs, your package includes this manual, the *FILE/80 Pocket Guide*, and the FILE/80 Demonstration Disc. This manual contains many examples that are stored on the FILE/80 Demonstration Disc. These examples enable you to see many of the capabilities of FILE/80 firsthand as you read about them in the manual. The *FILE/80 Pocket Guide* summarizes all aspects of this product and provides other general information.

Terms You Will Encounter

Character equivalents The fundamental storage unit of a computer. One character equivalent is identical to one byte of storage.

Control characters Characters obtained by holding **CTRL** and pressing another key on the HP-86/87 keyboard.

Cursor An inverse video rectangle that indicates where information can be entered on the HP-86/87 screen. To make it easy to locate, the cursor blinks if it is over an inverse video area.

Default drive A disc drive that is assigned as the default mass storage location. It can be changed by executing the `MASS STORAGE IS` command.

Field The basic unit in which FILE/80 stores information. This information can be different for each record. Each record in a file contains the same fields but the information in each field can be different.

File A collection of records that use the same master form. Each file has a name and password (optional). In addition, several output formats can be associated with a file.

Flexible disc Also called a *floppy disc*. A reusable storage medium that can be removed from a disc drive. There are four FILE/80 Program Discs and one FILE/80 Demonstration Disc. You can store files on an initialized disc with sufficient space.

Form A blank copy of the master form that information can be entered on.

Format Refer to Output format.

Hard disc *Also called a fixed disc.* A mass storage device that uses a rigid rotating surface as a storage medium. A hard disc is hermetically sealed and can normally provide several volumes of storage.

Information window The central 18 lines of any screen displayed by the FILE/80 program. Forms up to 60 lines long can be scrolled in this window with **(ROLL)**.

Leading blanks The spaces in a field to the left of the information entered.

Load The process of retrieving a program from disc and placing it into the memory of the computer.

Master form An 80-character by 60-line form the user defines. Each file has one master form. All the records in a file are identical to this form except that each field will have specific information in it. Each master form can contain up to 100 fields.

MSUS The mass storage unit specifier. Refer to your HP-86/87 operator's literature for instructions to determine the MSUS.

On-line When a peripheral device connected to your HP-86/87 can accept information sent by the computer.

Output format An output format is a file with the necessary information to output data from the records in your file to a printing device. There are three types of output formats: reports, letters, and labels. Up to 100 fields can be included on a format. Each format has a name like a file and can only be used when accessing the file for which it was defined.

Record A set of information in fields that are added to a file. Each record can contain different information. You enter or access this information with the **SEARCH** screen.

Sort string The combination of fields in the order designated on the **SORTED REPORT**, **SORTED LETTER**, or **SORTED LABEL** screens. These fields are used to arrange records when output is produced.

Special function window The set of special function keys displayed on the lower portion of any screen FILE/80 displays on your HP-86/87. Each screen has its own special function window.

Tab stop A field selected on the **TABS** screen. By pressing **(CONT)** you can move the cursor forwards to the next tab stop on the master form. You can move the cursor backwards to previous tab stops by holding down **(SHIFT)** and pressing **(CONT)**.

Text Any non-control HP-86/87 keyboard characters. These characters are entered on the master form and appear the same on each record in a file. On output formats, text also appears the same on each report, letter, or label.

Title/feedback window The upper portion of the HP-86/87 screen used by the FILE/80 program. This window contains a name that identifies each screen. Prompts, messages, counters, and assorted indicators are also displayed in the title/feedback window.

Trailing blanks Spaces in fields to the right of the information entered.

File Management—A Perspective

FILE/80 turns your personal computer into a paperless, electronic filing system. The high-resolution display makes the documents in your electronic file as easy to read as a typewritten sheet of paper. Once you've set up an application that meets your needs, FILE/80 can automatically process information in a specific file. Your file records are safely kept on discs, a reusable storage media.

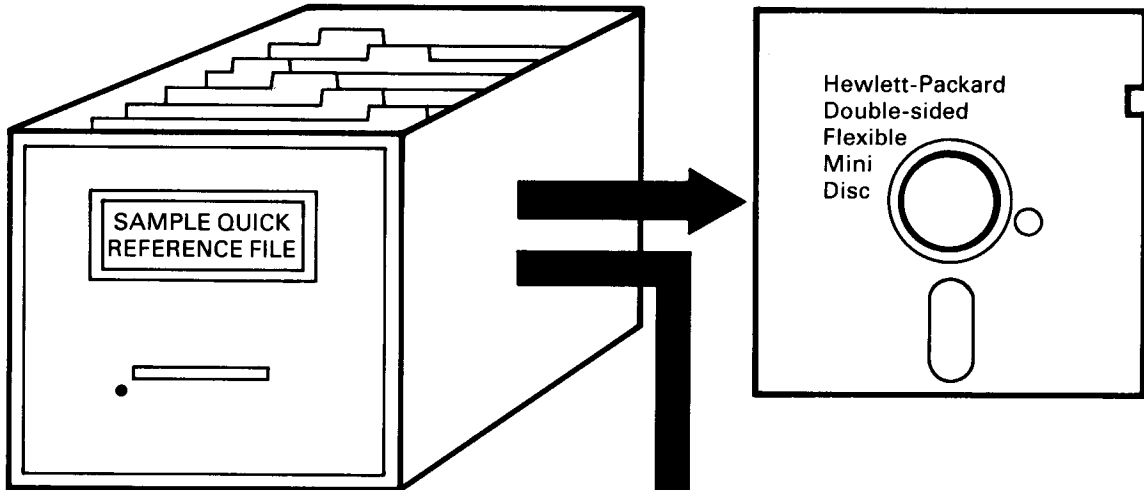

The SAMPLE QUICK REFERENCE FILE is described in section 2. Its records could be stored in this filing cabinet drawer.

Many paper documents like those stored at the left can be stored on one flexible disc. The number of documents stored depends on how much information is stored with each document.

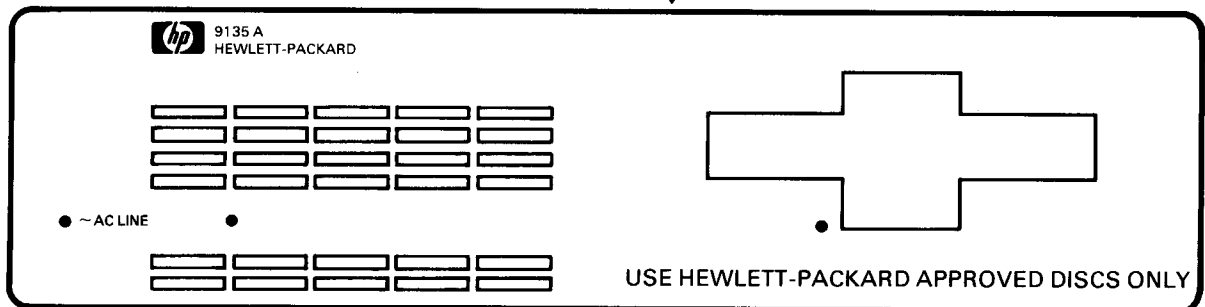

Many times the number of records stored on a flexible disc can be stored on the Winchester Disc Drives. A hermetically sealed hard disc inside these units can provide several volumes of storage. Once again, remember the number of records stored depends on the amount of information stored with each record. More master forms can be stored on flexible or hard discs when the forms have a fewer number of fields.

Using This Manual

This manual uses an integrated approach to quickly familiarize you with FILE/80. The CLIENTS file, stored on the FILE/80 Demonstration Disc, contains 30 records. All examples in this manual use the actual records, reports, letters, and labels stored in this file.

The following conventions are used to emphasize information in this manual. **Boxes** enclose information that allows you to use specific features of FILE/80. **Notes** supply additional clarifying information. The remaining text, diagrams, and screens presented in each section give you the knowledge to use FILE/80—such as instructions for using the FILE/80 Demonstration Disc.

Section 1 introduces you to the output capability of FILE/80. You can produce reports, letters, and labels from the CLIENTS file. You can also view actual records in the CLIENTS file on the screen of your HP-86/87.

In sections 2 and 3, you discover how to use FILE/80 Program Disc #1 to create and access files:

Section 2 explains how a file is created and stored on disc. The entries on the master form, the basis of the filing system used by FILE/80, are covered. You are instructed to create a file that can be stored on the FILE/80 Demonstration Disc.

Section 3 instructs you to access specific records stored on the FILE/80 Demonstration Disc. Examples show you how to add, update, and delete records. You will also become familiar with the screens and special function keys used to retrieve records.

In sections 4, 5, and 6 you learn how to create output formats with FILE/80 Program Disc #2 and how to print reports, letters, and labels with FILE/80 Program Disc #3:

Section 4 leads you through the definition and printing of reports. Each type of entry is covered. Additional entries used on the FILE/80 Demonstration Disc are listed at the end of the section.

Section 5 shows you how to define and print letters. All entries on the letter stored on the FILE/80 Demonstration Disc are listed at the end of the section.

Section 6 covers the definition and printing of labels. Entries used on the FILE/80 Demonstration Disc are listed at the end of the section.

Section 7 explains how to change files using the REDEFINE screen after records have been stored in them. FILE/80 Program Disc #4 is used.

Section 8 covers the use of *mass storage commands* with the FILE/80 program.

Section 9 explains how to protect your discs by making and using backup copies of your files. The BACKUP program, stored on FILE/80 Program Disc #4, is used.

Section 10 explains how to restore damaged files with the RECOVERY program when recent backup copies are not available. (In some cases, the entire file cannot be restored.) FILE/80 Program Disc #4 is used.

The FILE/80 Display

The following screen shows a file record that is being accessed. The record on this screen is stored in the CLIENTS file, on the FILE/80 Demonstration Disc. You will learn how to access this record before finishing section 1.

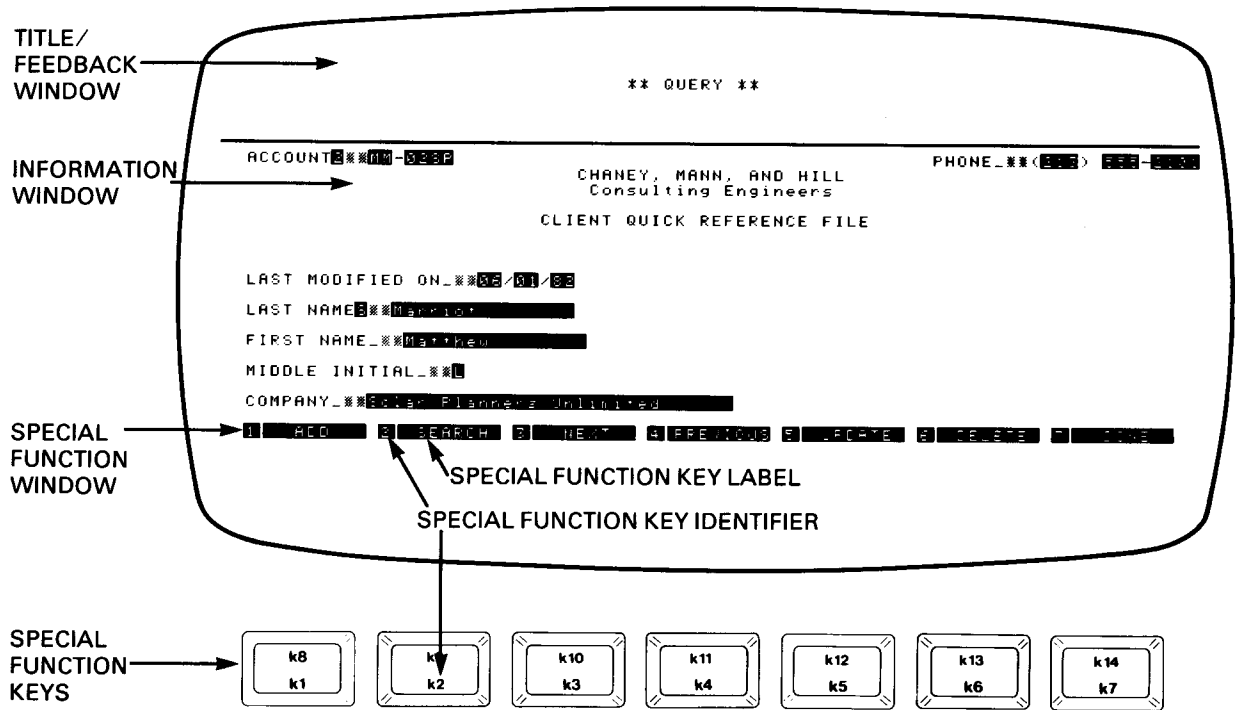

By holding down `(SHIFT)` and pressing any special function key, a help message is displayed in the title/feedback window that explains what the special function key is used for.

Notice the display is divided into three sections called windows. When the FILE/80 program is running, your personal computer always displays 24 lines on the screen. The 24 lines make up the three windows.

The title/feedback window identifies the screen you are looking at. A screen with the characters `*** QUERY ***` in the title/feedback window, for example, is identified as the `QUERY` screen. Messages, prompts, and various indicators are often displayed in the title/feedback window.

The central window on your screen is the information window. Although only 18 lines are displayed at a time, records up to 60 lines long and entire reports, letters, or labels can be viewed from the information window.

The **(ROLL)** key can be pressed to scroll the form displayed in the information window. The title/feedback window remains in place when you scroll the form. When a report output format is displayed in the information window, you can scroll it *horizontally* by pressing the **(←)** and **(→)** keys if the report exceeds 80 columns in width.

The special function window displays the labels for the special function keys. The special function key labels displayed on the screen describe the purpose of the special function keys on the computer. The special function key identifiers, **[1]** through **[7]**, correspond to the special function keys **(k1)** through **(k7)**.

The special function keys are only activated when they are useful. If a special function key is disabled, the associated special function key label is blank. Besides the special function keys, all other keys on the HP-86/87 keyboard are disabled by FILE/80 when they aren't needed. When you press a disabled key, the computer beeps.

Hard-Copy Output

In order to use the FILE/80 file management system to its greatest potential, a printer is required. Hewlett-Packard offers several models that interface with the HP-86 and HP-87. Depending on your application, the quality of printed output may or may not be important. Refer to appendix C for a listing of printers supported by FILE/80. Instructions are also provided for setting the default printer type on the **DEFAULTS** screen.

On the following pages, samples of the hard-copy output you can produce with FILE/80 are shown. Instructions for producing each of these documents from the **CLIENTS** file, stored on the FILE/80 Demonstration Disc, are provided in section 1.

ACCOUNT_##MM-02SP	CHANEY, MANN, AND HILL Consulting Engineers	PHONE_##(213) 555-2101
CLIENT QUICK REFERENCE FILE		
LAST MODIFIED ON_## 7/30/82		
LAST NAME_##Marriot		
FIRST NAME_##Matthew		
MIDDLE INITIAL_##L		
COMPANY_##Solar Planners Unlimited		
ADDRESS 1_##4275 Willis Avenue		
ADDRESS 2_##		
CITY/STATE_##Van Nuys, California		
ZIP CODE_##91403		
ACCOUNT REF_##Mr. Dyer		
HOURS LOGGED_## 4 MONTHLY		
LAST CONTACTED_## 7/14/82		
PROJECT_##0206		
CLASSIFICATION_##01-CS		
CONSULTING REQUIREMENTS_##Concrete Foundations		
PROFITABILITY INDEX_## 1		
1. Subtract TOTAL AMOUNT PAST DUE from YTD BUSINESS VOLUME.		
2. Divide difference obtained by YTD BUSINESS VOLUME.		
PROJECT FROM_## 6/ 1/82 TO_##		
TOTAL HOURS ALLOTTED_## 4		
CLIENT SINCE_## 2/14/75		
TOTAL AMOUNT PAST DUE_###	.00	YTD BUSINESS VOLUME_### 120.00
AMOUNT PAID THIS MONTH_###	120.00	YTD CONSULTING HOURS_## 4
RATE SCHEDULE 1_### 30.00		HOURS THIS MONTH 1_## 4
RATE SCHEDULE 2_### 45.00		HOURS THIS MONTH 2_## 0

Sample Form

This form is 80 columns wide by 60 lines long. You can print one of these documents for each record in your file as well as a listing of fields entered on the master form (page 56). Instructions are provided in the next section.

CHANEY, MANN, AND HILL
Consulting Engineers

2250 Camden Avenue, Los Angeles, California 90033

8/12/82

Matthew L. Marriot
Solar Planners Unlimited
4275 Willis Avenue
Van Nuys, California 91403

Dear Matthew,

Our firm is pleased to be able to offer the consulting area of Solar Engineering to our already broad range of services. Dr. David Alvord, a recent graduate of the Solar Engineering program of the University of Hawaii has recently joined the staff of CHANEY, MANN, and HILL. We know that you can benefit from the services of Dr. Alvord in any new or existing projects that you consider integrating with solar power.

Your account representative, Mr. Dyer, would be pleased to provide you with details. To schedule an appointment with Dr. Alvord, call our offices at 1-800-555-4567.

Cordially,

Bill Chaney, President

Sample Letter

One of these letters can be printed for all recently contacted clients. Letters can include fields directly from the master form, like the ACCOUNT REP field used in this letter.

MAILED 8/12/82 PRE-SORTED
 Cliff Robinson
 51 Marsh Boulevard
 Boston, Massachusetts 02178

MAILED 8/12/82 PRE-SORTED
 Howard Goodman
 Goodman Building
 2350 Alder
 Norfolk, Virginia 23563

MAILED 8/12/82 PRE-SORTED
 Robert Rutherford
 150 South Wilton Place
 Los Angeles, California 90004

MAILED 8/12/82 PRE-SORTED
 Julian Whitaker
 Suite 300, Whitaker Building
 2200 South Union Avenue
 Los Angeles, California 90007

MAILED 8/12/82 PRE-SORTED
 Paul Johns
 200 Veteran Avenue
 Los Angeles, California 90024

MAILED 8/12/82 PRE-SORTED
 Sam Berry
 1825 Prosser Avenue
 Los Angeles, California 90025

MAILED 8/12/82 PRE-SORTED
 Steve Rust
 Office A-24
 879 Athens Boulevard
 Los Angeles, California 90044

MAILED 8/12/82 PRE-SORTED
 John Marr
 8600 Aqueduct Avenue
 San Fernando, California 91343

MAILED 8/12/82 PRE-SORTED
 Matthew Marriot
 4275 Willis Avenue
 Van Nuys, California 91403

MAILED 8/12/82 PRE-SORTED
 John Marks
 10350 Peach Grove
 North Hollywood, California 91601

MAILED 8/12/82 PRE-SORTED
 John Stark
 5823 Coldwater Canyon Avenue
 Los Angeles, California 91607

MAILED 8/12/82 PRE-SORTED
 James Brady
 201 Magnolia
 Modesto, California 95354

Sample Labels

One label can be printed for each file record. You can print mailing labels in zip code order for addressing envelopes. In addition to the current date, any field on the master form can be printed on labels.

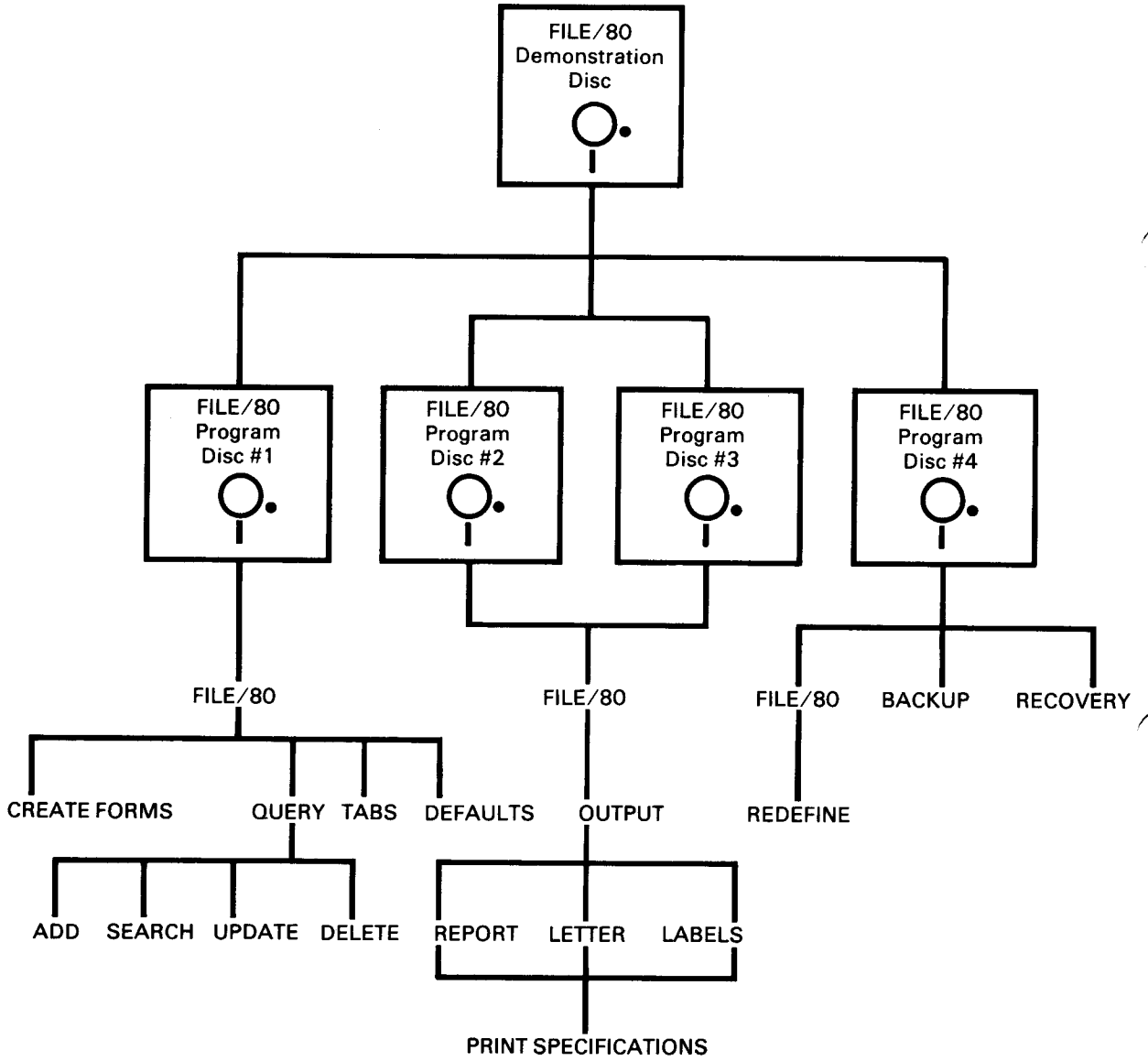

Overall FILE/80 Diagram

Getting Started

Introduction

This section explains how to use FILE/80 with your HP-86/87. You will learn how to display individual records. Later in this section, the FILE/80 Demonstration Disc is used to print reports, letters, and labels.

To operate FILE/80 properly, you will need the following hardware:

- An HP-86 or HP-87.
- A minimum of 96K bytes of user memory (RAM).
- One dual flexible disc drive, two single disc drives, or a hard disc drive with flexible disc access.
- Printer to produce hard-copy output, if desired.
- Interconnect cables.

Additional memory beyond 96K bytes is not necessary but does shorten the processing time when sorting records for output or reorganizing files.

Note: For more information about connecting disc drives, printers, and other peripheral devices to your computer, refer to the owner's manual or other literature supplied with each device.

It is recommended you make and use working copies of all the discs supplied with this package. These include the FILE/80 Program Discs and the FILE/80 Demonstration Disc. Place write-protect tabs on the copies of the program discs. Keep the original discs for archive purposes. Refer to your HP-86/87 owner's literature for instructions on copying discs.

WARNING

It can be necessary to change the program media (flexible discs) while the FILE/80 program is running. FILE/80 will prompt you whenever a media change is required. **DO NOT CHANGE MEDIA WITHOUT BEING INSTRUCTED TO DO SO.** Changing media, opening disc drive doors, or turning a disc drive off without being prompted can result in corruption of your files and possible loss of data. Pressing **RESET** twice while the program is running can have the same consequences.

Not all the program segments stored on the FILE/80 Program Discs are loaded into your HP-86/87 simultaneously. When the FILE/80 program is running, different program segments are automatically loaded when they are needed. When this occurs, a message is displayed on the screen explaining that the system is busy. Wait until the loading process is finished. If the FILE/80 Program Disc containing the needed segment is not on-line, then a message instructs you to insert a specific FILE/80 Program disc by its number (1, 2, 3, or 4). The name of the program segment is also provided.

Loading FILE/80

The following instructions are for flexible disc drives. A default mass storage unit specifier (MSUS) of :D700 is assumed. An MSUS of :D701 is also assumed. Your system might not have these exact MSUSs. If you have a different MSUS, simply substitute your own MSUS for the one used in this manual. Refer to your HP-86/87 owner's documentation for instructions on determining the correct MSUS for devices connected to your computer. The MASS STORAGE IS command can be used to change the default MSUS.

- a. Connect disc drives to your computer in the proper manner.
- b. If hard-copy output is to be produced, connect your printer with paper at proper top of form.

Note: It is recommended different addresses be used for your disc drives and printer.

- c. Apply power to all devices connected to your computer.
- d. Turn your computer on.
- e. Insert FILE/80 Program Disc #1 into the default MSUS of :D700 and the FILE/80 Demonstration Disc into MSUS :D701. Make sure the disc drive doors are closed.
- f. Enter the following command and press **(END LINE)**.
LOAD "FILE/80"
- g. Press the **(RUN)** key.

When the screen with the WELCOME TO FILE/80 message appears on your display, FILE/80 has been properly loaded. The POWER light on your computer should be blinking to indicate a program is being executed. Some plug-in ROM modules can reduce the amount of user memory FILE/80 can access. If sufficient memory is not available when **(RUN)** is pressed, then a message is displayed.

Demonstration of FILE/80

Follow the previous instructions for loading FILE/80. After the WELCOME TO FILE/80 message is displayed, you are ready to begin.

Press the **OLD FILE** special function key and enter the file name CLIENTS followed by **END LINE**. When the password is requested, enter HP and press **END LINE**. This gives you access to a file on the FILE/80 Demonstration Disc. Later on, you can store some of your own files on this disc.

After entering the file name and password, this screen is displayed. Just follow the instructions in the title/feedback window. For example, if the current date is August 12, 1982:

Press **0 8 1 2 8 2** **END LINE**

The screenshot shows a terminal window with the following text:

```

FILE NAME: CLIENTS          ** FILE/80 **
ENTER TODAYS DATE (MM/DD/YY) 08/12/82
:
1 _____ 2 _____ 3 _____ 4 _____ 5 _____ 6 ACCEPT 7 _____

```

FILE/80 Display

FILE/80 asks you to verify the device address of the printer and the MSUS of each disc drive attached to your personal computer. It is important you make sure this data is complete and correct. To change the printer address displayed in the title/feedback window, press **PRINTER**, enter the correct address, and press **END LINE**. The **SPACE BAR**, **BACK SPACE**, **←**, and **→** keys can be used to edit an entry before pressing **END LINE**.

The MSUSs of the drives where the FILE/80 Program Disc #1 and the FILE/80 Demonstration Disc are located need to be present. At least two MSUSs are required unless a hard disc is on-line. To enter an MSUS, press **NEW**, enter the digits, and then press **END LINE**. To remove an MSUS recorded as being on-line, press **DELETE**, enter the digits on the screen, and press **END LINE**.

When the printer address and the table of drives on-line are correct, press **ACCEPT**. When the next screen is displayed, press **QUERY** to view the individual records in the CLIENTS file.

Press **QUERY**

```

FILE NAME: CLIENTS          ** FILE/80 **          TODAY'S DATE 08 13 88
Please select a special function key.
:
1 QUERY  2 OUTPUT  3 REDEFINE  4 TABS  5 DEFAULTS  6 EXIT  7 DONE

```

FILE/80 Display

You should now have three special function keys on your screen— **ADD** , **SEARCH** , and **DONE** . Press the **SEARCH** special function key. The **SEARCH** screen is displayed. You are looking at a blank copy of the master form used to store each record in the **CLIENTS** file. (In section 2 you will learn how to create master forms.) **FILE/80** requires records to be unique. To access records, you make an entry on the blank form displayed. For example, to retrieve records in the **CLIENTS** file for account number **MM-02SP**, you look for the **ACCOUNT** field on the master form and enter **(M)(M)(O)(2)(S)(P)** in it.

Notice the **ACCOUNT** field is located in the upper left of the information window. Also notice it is displayed with inverse video. This means the cursor is currently on the **ACCOUNT** field and you can enter information into it. The cursor is automatically positioned on the first field of a record when it is accessed.

You can press **(END LINE)** to move the cursor to the next field. Or, you can hold down **(SHIFT)** while pressing **(END LINE)** to move the cursor to the previous field. Try pressing **(END LINE)** . The name of the next field, **PHONE**, is now displayed with inverse video. Move the cursor back to the **ACCOUNT** field by pressing **(SHIFT) (END LINE)** . Then press the keys indicated to retrieve a record for **ACCOUNT MM-02SP** from the **CLIENTS** file:

Press (M) (M) (O) (2) (S) (P) ACCEPT

** SEARCH **

ACCOUNT#MM-02SP

CHANEY, MANN, AND HILL
Consulting Engineers

PHONE_##(< >) -

CLIENT QUICK REFERENCE FILE

LAST MODIFIED ON_##/##/##

LAST NAME_#

FIRST NAME_#

MIDDLE INITIAL_#

COMPANY_#

1 RELATION 2 RANGE 3 PANY CHR 4 #MATCH 5 FORM 2 6 ABORT 7 ACCEPT

FILE/80 Display

The record for account number MM-02SP is displayed on the QUERY screen. You can press the special function key **NEXT** to see if any other records in the CLIENTS file also have this account number. Actually, there are three separate records in the CLIENTS file for account number MM-02SP. These records are distinguishable by entries in the PROJECT field: 0206, 0207, and 0208. To display the PROJECT field, press **CONT** twice. You can view each of these records in succession by pressing **NEXT**. Many times, it is advantageous to access groups of records that satisfy certain conditions. You will learn how to do this in section 3.

The record you see on the QUERY screen (next page) is just part of a 60-line record that stores information for each project of the Consulting Engineering firm CHANEY, MANN, and HILL. By pressing **CONT** or **SHIFT ROLL**, you can move forwards through the file record for account number MM-02SP, Solar Planners Unlimited. Press **SHIFT CONT** or **ROLL** to move in the opposite direction. You can view the 60-line record through the information window of the QUERY screen.

Whenever a file record is displayed on the QUERY screen as a result of a search, you can press **LIST** to obtain a hard copy of it. To print copies of all records accessed with a search, press **PLST**. With the current search conditions, records for projects 0206, 0207, and 0208 can be printed by pressing **PLST**.

In the next part of the FILE/80 demonstration, you can produce additional hard-copy output from the CLIENTS file. To continue with the FILE/80 demonstration, press **DONE** on the QUERY screen.

Press **DONE**

```

** QUERY **

Please select a special function key.
-----
ACCOUNT#***MM-028P                                PHONE_***(<213> 555-2101
                                CHANEY, MANN, AND HILL
                                Consulting Engineers
                                CLIENT QUICK REFERENCE FILE

LAST MODIFIED ON_**06/01/82
LAST NAME#***Marriot
FIRST NAME_**Matthew
MIDDLE INITIAL_**
COMPANY_***Solar Planners Unlimited

1. ADD      2. SEARCH  3. NEXT  4. _____  5. UPDATE  6. DELETE  7. DONE

```

FILE/80 Display

When the FILE/80 screen is displayed, do the following:

Press **OUTPUT**

```

** FILE/80 **

:
:
:
1. QUERY  2. OUTPUT  3. REDEFINE  4. TABS  5. DEFAULTS  6. EXIT  7. DONE

```

FILE/80 Display

Whenever output is produced, the name of an *output format* is entered. This name tells FILE/80 which report, letter, or label format you want. To print a report just like the one shown in the overview, do the following:

Press **R E P O R T** **ENDLINE**

```

** OUTPUT **
FORMAT NAME? REPORT

```

1 **COMP ALL** **2** **_____** **3** **_____** **4** **_____** **5** **_____** **6** **RESET** **7** **_____**

FILE/80 Display

FILE/80 will prompt you to insert FILE/80 Program Disc #3. Replace FILE/80 Program Disc #1 with FILE/80 Program Disc #3. Do not remove the FILE/80 Demonstration Disc. After you have inserted the new program disc, press **CONTINUE**.

The **PROJECT SUMMARY REPORT** is printed from the records stored in the **CLIENTS** file. This report summarizes each record stored on the FILE/80 Demonstration Disc. If you were to update any record in the **CLIENTS** file, then the **PROJECT SUMMARY REPORT** would reflect this change. (You will learn how to update records in section 3.) Press the **DEFAULTS** special function key on the **PRINT SPECIFICATIONS** screen:

Press **DEFAULTS**

```

** PRINT SPECIFICATIONS **           Format: REPORT
Please select a special function key.

```

1 **EDIT** **2** **DEFAULTS** **3** **SEARCH** **4** **_____** **5** **_____** **6** **ABORT** **7** **PRINT**

FILE/80 Display

Check the list displayed in the information window of the DEFAULTS screen. Make sure the Printer address and Printer type settings are compatible with your own computer system. The Form size (Lines) setting should also be checked.

- **Printer address:** This should be set to the address of your printer. You can refer to the owner's literature supplied with your HP-86/87 or printer for instructions to determine your printer's address.
- **Printer type:** Refer to appendix C to determine the correct setting.
- **Form size (Lines):** This is preset to 66—the number of lines on standard paper forms. If the forms you are using are non-standard, enter the number of lines that can be printed on a single page.

To change items on the default list:

- a. Press **END LINE** or **SHIFT END LINE** to move the cursor over the number of the item you wish to change.
- b. Press **CHANGE**.
- c. FILE/80 displays instructions for entering the changes from the keyboard. Make the requested entry and press **END LINE**.
- d. Repeat steps a through c until all items in the list have the settings you want.
- e. Press **ACCEPT**.
- f. The **PRINT SPECIFICATIONS** screen should now be displayed.

After you press **ACCEPT** on the DEFAULTS screen, the **PRINT SPECIFICATIONS** screen is displayed. You can begin printing the **PROJECT SUMMARY REPORT** shown in the overview by pressing **PRINT**. While your report is being printed the **REPORT** screen is displayed. Each page of your report is also displayed in the information window as it is printed.

```

Printing record #4
Printing Format: REPORT
** REPORT **
Printing is ON
Display is ON
-----
                CHANEY, MANN, AND HILL                8/12/82
                Consulting Engineers

                PROJECT SUMMARY REPORT

CLASS  PROJECT      HOURS      VOLUME      PAST DUE  PROFIT INDEX
01-CS  1202            320      $10200.00      $.00          1
        0206            4        $120.00        $.00          1
        0207            7        $210.00      $135.00  .35714285714
        0307            13       $465.00      $96.00  .79354838709
1 PAUSE  2 3 4 5 6 REPORT 7

```

FILE/80 Display

When your report has finished printing, a new special function window is displayed on the REPORT screen. You can press **EXIT** to end the demonstration. To continue with the demonstration, follow these instructions:

- a. Press **OUTPUT**.
- b. Select one of these options:
 1. To print 30 file records with a master form summary, press **DUMP ALL**.
 2. To print 12 sample letters, enter the format name **LETTER** and press **ENDLINE**.
 3. To print 12 sample labels, enter the format name **LABEL** and press **ENDLINE**.
- c. The **PRINT SPECIFICATIONS** screen is displayed.
- d. Press **DEFAULTS** to check the current defaults. Use the procedure on page 26 for changing defaults.
- e. Press **ACCEPT** on the **DEFAULTS** screen.
- f. Verify that paper is at proper top-of-form.
- g. Press **PRINT** on the **PRINT SPECIFICATIONS** screen to begin printing.
- h. After the output has completed printing, press **EXIT** to end the demonstration or repeat steps a through g for additional output.

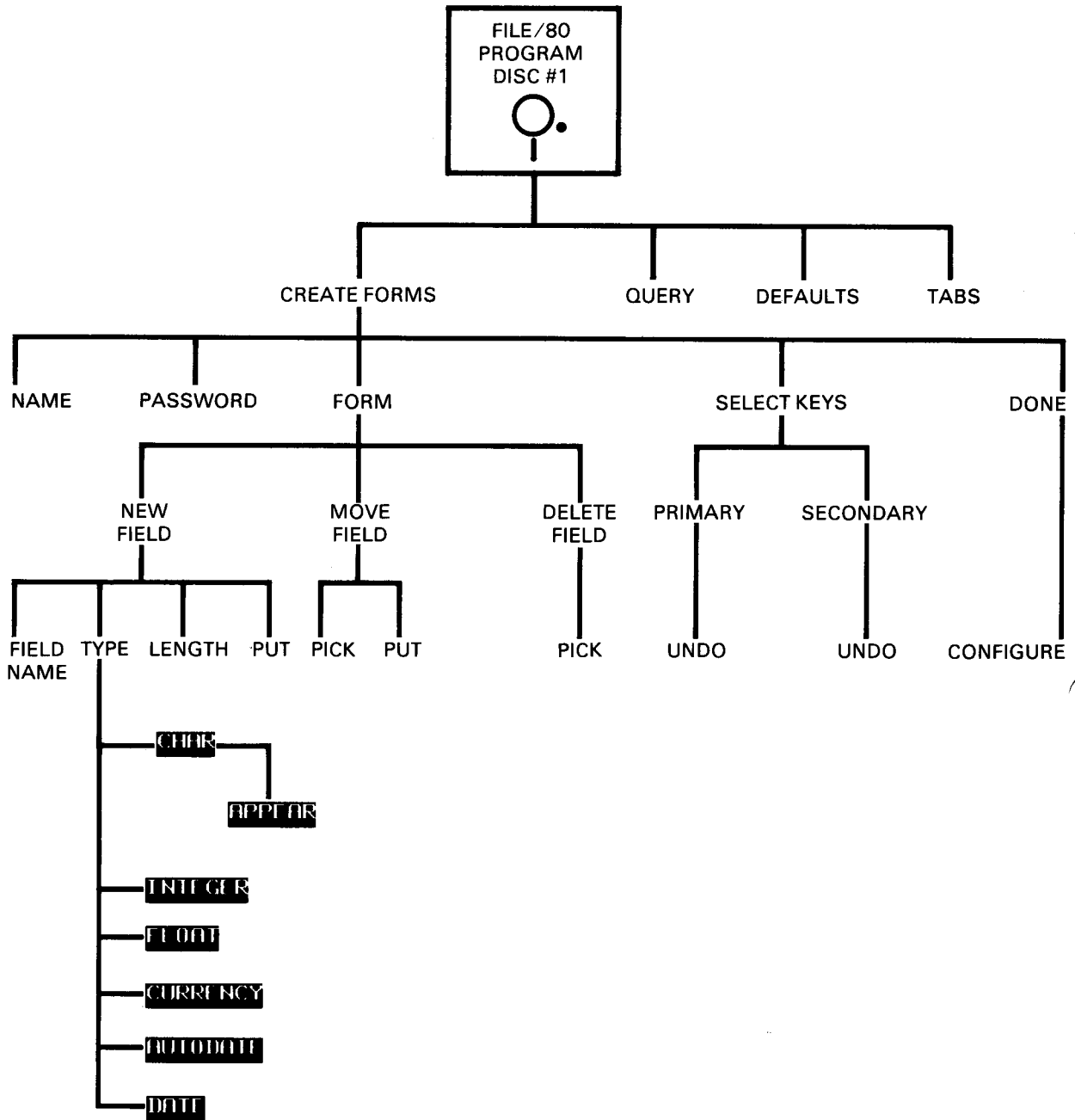

CREATE FORMS Diagram

Creating Master Forms

The master form, which is the basis of the filing system used by FILE/80, is created in this section. Sections 3 through 6 of this manual explain how to access and process individual records stored with the master form.

Records in a file are like the paper documents and forms that can be stored in filing cabinets. Examples throughout this section show you how each record in a file is created. Each record in your file is formatted according to the master form. With the `CREATE FORMS` special function keys, you and FILE/80 create the master form.

You are instructed to create a master form identical to the master form used on the FILE/80 Demonstration Disc in this section. The master form you will be creating is pictured in the overview. Instead of being for the `CLIENTS` file, which is stored on the FILE/80 Demonstration Disc, the master form you create in this section will be for the `SAMPLE` file. The operations in this section can be performed with any of these discs:

- The FILE/80 Demonstration Disc.
- Any flexible or hard disc with some extra space. Other files can already be stored on this disc.
- An empty disc that has been initialized.

All discs you intend to use for storing data must be on-line before creating the file.

Introduction

FILE/80 always displays the master form you're designing on the screen of your HP-86/87. It appears the same as it would on a sheet of paper and yet you can change it. This enables you to design the master form as you create it. The `CREATE FORMS` screen aids you in the design of the master form by only providing special function keys that are useful. The master form is 80 characters wide. This matches the width of the HP-86/87 display screen. It can contain up to 60 lines of information. The diagram on the facing page shows the organization of the special function keys used to create a master form.

After the master form has been created and stored on disc it can still be changed. However, changing a master form already stored on disc requires several steps not necessary during the initial creation. These additional steps are necessary because data can already be stored in the forms of the original file.

Starting Forms Creation

Follow these instructions for loading FILE/80:

- a. Connect disc drives to your computer in the proper manner.
- b. Apply power to all devices connected to your computer.
- c. Turn your computer on.
- d. Insert the FILE/80 Program Disc #1 into the default MSUS of :D700 and the FILE/80 Demonstration Disc into MSUS :D701. Make sure the disc drive doors are closed.
- e. Enter the following command and press **ENDLINE**.
LOAD "FILE/80"
- f. Press the **RUN** key.

This screen is displayed. To begin the creation of a master form, do the following:

Press **NEW FILE**

```

** FILE/80 **
WELCOME TO FILE/80.
:
:
1 NEW FILE 2 OLD FILE 3 _____ 4 _____ 5 _____ 6 EXIT 7 _____

```

FILE/80 Display

These special function keys are provided:

NEW FILE Press this special function key to begin the creation of a new master form. You are requested to enter the name and password of the new file. You choose both of these.

OLD FILE Press this special function key to access a file already stored on disc. FILE/80 prompts you for the name of the file and then the password (if one has been designated).

[X] I Press this special function key to exit FILE/80. Your HP-86/87 returns to calculator mode. To access or create files, you must reload the FILE/80 program and press **(RUN)**. Any information entered in the current session, such as the file name, password, or date must be entered again.

File Names and Passwords

Each master form you create is associated with a single file. Whenever you access a file, you must supply the file name and, if applicable, a password. You are prompted to enter the file name after pressing **NEW FILE** on the FILE/80 screen.

File names can contain any upper or lower case letter or digit and have a maximum length of eight characters. Do not use the characters period, comma, or semicolon in the file name. It is also important not to use the name of any file currently on-line. Passwords can contain up to 10 characters.

After you press **NEW FILE**, the prompt `ENTER THE FILE NAME` is displayed. To enter the file name SAMPLE, for instance, press the following keys:

(S) (A) (M) (P) (L) (E) (END LINE)

The name SAMPLE is displayed in the title/feedback window. This file name must be supplied when accessing this file in the future.

PASSWORDS: When the prompt `ENTER THE PASSWORD` appears, you can enter a password (10 characters or less) and press **(END LINE)** or just press **(END LINE)** to override the password option. If you do enter a password, record it on a sheet of paper for future reference. After the file has been created, it will be impossible to access it again without the password.

File Configuration

After entering the file name and password, FILE/80 asks you three questions for configuring your file. These parameters are only entered once. They cannot be changed after your file has been stored on disc.

- Ordering of month, day, and year when dates are displayed or printed.
- Characters used to separate the month, day, and year when dates are displayed or printed.
- A character to be used as the currency sign. This character appears immediately to the left of monetary amounts when they are printed.

After you enter the file name and password, this screen is displayed for configuring your file.

```

FILE NAME: SAMPLE                ** FILE/80 **                DATES: MM-DD-YY
Please select a key to indicate how dates are to be displayed.

1 MM-DD-YY  2 DD-MM-YY  3 YY-MM-DD  4 _____  5 _____  6 _____  7 _____

```

FILE/80 Display

Press a special function key to choose how dates in your file will be displayed. If you press **MM DD YY**, for example, dates will be displayed in a *month day year* format. After you select the format, this screen is displayed:

```

FILE NAME: SAMPLE                ** FILE/80 **                DATES: MM-DD-YY
Please select the insertion character you want in the date.

1 MM-DD/YY  2 MM-DD.YY  3 MM-DD-YY  4 _____  5 _____  6 ABORT  7 _____

```

FILE/80 Display

You can choose the slash (/), the period (.), or the hyphen (-) to separate the month, day, and year. Press the appropriate special function key to indicate your choice. To change the *ordering* of the month, day, and year, you can press **ABORT**. After you choose the slash, period, or hyphen, this screen is displayed:

```

FILE NAME: SAMPLE          ** FILE/80 **          DATE: MM DD YY
CURRENCY SIGN $
Please enter the currency sign.
-----
1 _____ 2 _____ 3 _____ 4 _____ 5 _____ 6 ABORT 7 _____

```

FILE/80 Display

You can enter up to four characters for the currency sign. Type in the currency sign of your choice and press **END LINE**. The characters displayed beside the CURRENCY SIGN prompt determine what currency sign is used for your file. The dollar sign (\$) is already displayed in the field. Press **END LINE** to select the dollar sign.

In this manual, all files have the following configuration:

- MM DD YY format.
- / insertion character for dates.
- \$ currency sign.

After these items have been specified for your file, FILE/80 prompts you to enter the current date.

Entering Peripherals

The printer address needs to be entered. FILE/80 displays the default address of **701** in the printer address prompt. To enter the default address of **701**, press **END LINE**. Next, the MSUS of each drive that contains a disc to be used by FILE/80 needs to be entered. Unless a hard disc is on-line, at least two MSUSs must be entered.

If the file you are creating is large, it can span several volumes. The MSUSs for all volumes on which a file is to be stored must be entered. All these volumes must be on-line whenever the file is accessed. In addition, the MSUSs of the FILE/80 Program Discs need to be entered. A dual flexible disc drive normally has the MSUSs :0700 and :0701. To enter these, do the following:

Press (7)(0)(0) (ENDLINE) **NEW** (7)(0)(1) (ENDLINE) **ACCEPT**

The screenshot shows a terminal window titled "FILE/80 Display". At the top left, it says "FILE NAME SAMPLE". In the center, it says "** FILE/80 **". On the right, there is a header for a table: "TABLE OF DISC DRIVES". Below this, a horizontal line separates the header from the table content. The table has two columns, both labeled "DRIVES ONLINE". The first column contains the text ":D700" and the second column contains ":D701". At the bottom of the screen, there is a menu of special function keys: 1. NEW, 2. [blank], 3. [blank], 4. DELETE, 5. PRINTER, 6. [blank], 7. ACCEPT.

FILE/80 Display

The special function keys on this screen are used for changing the printer address and adding or removing MSUSs from the table displayed in the information window. To enter the first MSUS, type in the digits and press (ENDLINE). For each additional MSUS you enter, the **NEW** special function key must be pressed once.

NEW When you press this key the prompt ENTER THE MSUS OF THE NEW DISC DRIVE ":D []" is displayed. Press **NEW** once to enter an MSUS. After entering the digits, press (ENDLINE).

DELETE Press this key to remove any MSUS already displayed on the screen. When pressed, the prompt ENTER THE DISC DRIVE MSUS YOU WANT TO DELETE ":D []" is displayed. You enter the digits and press (ENDLINE). The MSUS you entered is removed from the table.

PRINTER Press this key to change the printer address currently displayed in the title/feedback window. When the prompt appears, enter the digits and press (ENDLINE).

ACCEPT When each MSUS on the screen is correct, you press this special function key to continue creating the master form.

After each MSUS has been entered, check over the table to verify that all MSUSs are correct and that the table is complete. Then press **ACCEPT**. This completes the process of entering MSUSs. FILE/80 gives you the option of updating this table during future sessions.

The Master Form

Whenever you create a master form, there are two basic types of entries that are made on the form, *fields* and *text*. Use fields for information that can change from one record to the next. Text appears the same on each file record. Instructions for defining, moving, and deleting fields follow.

A maximum of 100 fields, with a combined length of 1,020 character equivalents, can be placed on the master form. In addition, you can enter up to 4,800 characters of text. The dimensions of the master form are 60 lines by 80 columns. The FILE/80 program does not allow you to create a master form that exceeds these limits. A table of character equivalents is provided on page 55. Text entry instructions are provided later in this section.

The master form used on the FILE/80 Demonstration Disc consists of fields and text. A list of the entries is provided at the end of this section. By following the instructions for defining fields, you can “recreate” the same master form that was used for the sample report, letter, and mailing label shown in the overview. To place fields or text on a master form, you must press **FORM** on this screen.

Press **FORM**

```

FILE NAME: SAMPLE          ** CREATE FORMS **          PASSWORD:
:
:
1 NAME  2 PASSWORD  3 FORM  4 _____  5 _____  6 EXIT  7 _____
  
```

FILE/80 Display

If necessary, you can change the name of your file or its password by pressing the **NAME** or **PASSWORD** keys, respectively. Or, you can press **EXIT** to return to calculator mode. When **FORM** is pressed, this screen is displayed:

```

          ** CREATE FORMS **
form line 1 column 1
:
:
1 NEW  2 _____  3 _____  4 _____  5 COUNT  6 SPACE  7 ACCEPT
  
```

FILE/80 Display

The following special function keys are provided:

NEW Press this key to define an individual field to be placed on the master form.

COUNT Press **COUNT** to display a message indicating the total number of fields currently on the master form.

SPACE Press this key to display the number of character equivalents currently being used by the fields on the master form. This relates to the 1,020-character equivalent maximum of storage available on a master form.

ACCEPT Press **ACCEPT** when all field and text entries have been made on the master form. The **CREATE FORMS** screen with the **FORM** special function key is displayed.

Note the line and column counters in the title/feedback window. These continuously display the location of the cursor on the master form. To move the cursor across the surface of the master form, the cursor keys can be used. When the cursor is on the first or last line displayed, the master form is scrolled automatically with **↑** or **↓**. The cursor stays in the same column. These keys can also be used:

END LINE Press this key to move the cursor to column 1 of the next line on the master form.

CONT Press this key to display the next 15 lines of the master form. Successive 18-line segments of the master form are displayed with a 3-line overlap.

ROLL Press this key to scroll the master form.

With these keys, you can also hold **SHIFT** down and press the key to move the cursor or scroll the master form in the reverse direction. Even if the master form is blank, you can verify the location of the cursor with the line and column counters.

Fields

Fields allow you to enter information which can be different for each individual record. To begin the definition of a field you press **NEW** on the **CREATE FORMS** screen. **FILE/80** prompts you to do the following:

- Enter the field name.
- Select the type of the field.
- Enter the field length.
- Put the field on the master form.

After completing these steps, the new field becomes part of the master form. The field is displayed in the information window after entering the length or selecting the type of the field. If a field has a predefined length, it appears on the screen after the type is selected. When displayed in the information window, each field has the following configuration:

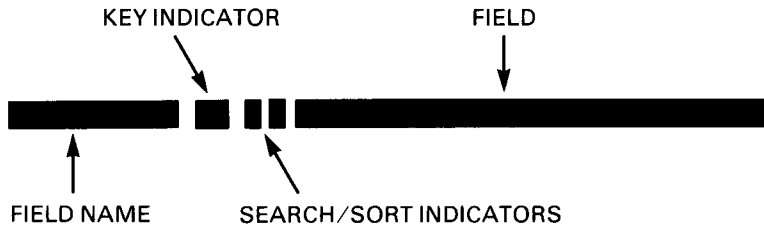

The characters you enter for the *field name* are displayed in the field name segment. In addition to appearing on the master form, field names can be used for automatic column headings on a report.

The *key indicator* is blank now. Fields designated for the primary key display the digits 1, 2, 3, or 4, denoting their order in the primary key. If you designate a field as a secondary key an S is displayed. A field designated as both a primary and secondary key only indicates the primary key field number. Both types of keys are covered under **Key Selection** on page 49.

The *search/sort indicators* perform dual functions. They can be used for specifying conditions on the SEARCH screen. This screen locates records in your file based on information you enter into any field on the master form and is covered in section 3. These indicators are used on the SORTED REPORT, SORTED LETTER, and SORTED LABEL screens also. You can choose the order that file records are accessed for printing reports, letters, or labels with these screens. Use of the search/sort indicators for producing output is covered in sections 4 through 6.

Entering Field Names

Entering the field name is the first step in defining a field. When **NEW** is pressed, this prompt is displayed in the title/feedback window:

ENTER THE NEW FIELD NAME

The cursor is located in the first character position of an inverse video strip. Field names can include any alphanumeric characters and have a maximum length of 27. Only blanks that are embedded in the field name are used—both leading and trailing blanks are removed.

If you don't want to give the field you're defining a name, just press **END LINE**. The **SPACE BAR**, **BACK SPACE**, **←**, and **→** keys can be used to edit the field name before pressing **END LINE**. To enter the field name **LAST NAME**, for example, do the following:

Press **L A S T SPACE BAR N A M E END LINE**

```

** NEW FIELD **
ENTER THE NEW FIELD NAME LAST NAME
_____

1 _____ 2 _____ 3 _____ 4 _____ 5 _____ 6 ABORT 7 _____

```

FILE/80 Display

After you press **END LINE**, the labels in the special function window change to allow you to select a field type for the **LAST NAME** field. These are shown on the next screen.

Field Types

FILE/80 gives you a choice of six field types: character (formatted or unformatted), integer, float, currency, autodate, and date. Different field types give you a variety of ways to use the information stored in each field. Field types are chosen with special function keys. You just press the special function key corresponding to the type of field you want.

If you enter a field name of LAST NAME, the following screen is displayed when **END LINE** is pressed. To select the character field type, you merely press the **CHAR** special function key. After pressing **CHAR**, a prompt is displayed in the title/feedback window requesting you to enter the length of the field.

Press **CHAR**

```

LAST NAME                ** NEW FIELD **

Select a field type from the special function keys.

1 CHAR  2 INTEGER  3 FLOAT  4 CURRENCY  5 AUTODATE  6 DATE  7 ABORT
  
```

FILE/80 Display

You can select any of six different field types by pressing the appropriate special function key:

CHAR Press this special function key to select a character field. You can then press **APPEAR** to enter a formatted character field.

INTEGER Press this special function key to choose an integer field. Computation can be performed with integer fields although no fractional numbers are allowed.

FLOAT Press this special function key to select a numeric field that can be stored with a variable number of decimal places. Only non-zero decimal places are displayed.

CURRENCY Press this special function key to select a numeric field with a currency sign and two decimal places.

AUTO DATE Press this special function key to select a date field that automatically registers the last date when file records were updated or added.

DATE Press this special function key to select a date field that can store any date you enter.

ABORT Press this special function key to display the NEW FIELD screen with the prompt ENTER THE NEW FIELD NAME in the title/feedback window. You can change the name of the field by entering a different name and pressing **END LINE**.

The Character Type

Character type fields can contain the letters A through Z (upper or lower case), the digits 0 through 9, or any non-control characters on the HP-86/87 keyboard. On the CLIENTS master form, the LAST NAME field has a length of 15. Any combination of 15 characters can be stored in this field. The name "Marriot" would be a good example. Since this name is seven characters long, there are eight trailing blanks in the LAST NAME field when the name Marriot is stored in it. The length of character fields can range from 1 to 50 characters.

FIELD
↓

LAST NAME S *** Marriot

↑
FIELD NAME

The use of character fields offers you the most versatility for items that don't require computation. Notice that character fields cannot be used for calculations, even though digits can be stored in them. Instructions for using the **APPEAR** special function key, which is displayed after **CHAR** is pressed, are provided under **Formatted Character Fields**, page 46.

The Integer Type

Integer type fields are numeric fields that have no decimal places. Computations are performed with integer type fields, so only the digits 0 to 9 can be entered in them. Both positive and negative values can be stored in these fields. The YTD CONSULTING HOURS field on the CLIENTS master form has a length of 9. If the number 4 is stored in this field, it appears on the right-hand side. The eight leading blanks are treated as zeros. Integer type fields can range in length from 1 to 12 digits.

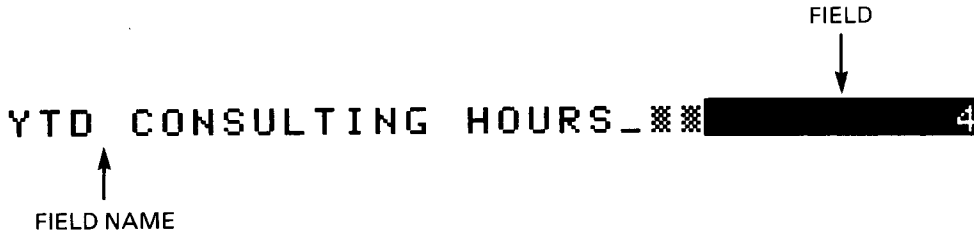

Integer fields are useful for storing values that don't have a decimal point. The minimum and maximum values that can be stored in an integer field are dependent upon the length of the field. An integer field with length 12 can store any number ranging from -99999999999 to 99999999999. When present, the minus sign is displayed immediately to the left of the number.

The Float Type

The float field is the most versatile numeric field offered by FILE/80. Any number that can be stored in your HP-86/87 can be stored in a float type field. You can enter numbers into a float type field with a decimal point and a power of 10 (preceded by the letter E). FILE/80 then displays the number with one digit to the left of the decimal point and adjusts the power of 10 accordingly. The PROFITABILITY INDEX on the CLIENTS master form is a float type field. It is eight digits long:



Because the number entered in this field is less than eight digits long, it isn't displayed as a power of 10. A decimal point is only displayed when the value stored is fractional or is displayed as a power of 10. The number of decimal places that can be stored in a float field depends on the length of the field. Float type fields can range from 8 to 19 digits.

The Currency Type

Currency type fields are used when monetary amounts are being stored. FILE/80 provides a decimal point and the currency sign entered when the file was configured. Calculations can be performed with numbers that are stored in currency fields. The YTD BUSINESS VOLUME field on the CLIENTS master form is a currency field. It has a length of 12:

FIELD
↓

YTD BUSINESS VOLUME_ ##\$ 120 . 00

↑
FIELD NAME

Currency fields can range in length from 3 to 12 digits. The maximum amount that can be stored in a currency field is 999999999.99. The minimum amount is -999999999.99. The range of values depends on the field length. With currency type fields, the minus sign always appears on the left side of the decimal point. On printed reports, letters, and labels, the currency sign is placed immediately to the left of the leftmost digit in the field or the minus sign, if present.

The Autodate Type

Autodate fields have a fixed length of eight characters. The date entered at the beginning of a session is automatically entered in autodate fields when records are added or updated in your file. The autodate field has the format selected during configuration such as MM/DD/YY. The M's, D's, and Y's, stand for the month, day, and year. The LAST MODIFIED ON field on the CLIENTS master form is an autodate field:

FIELD
↓

LAST MODIFIED ON_ ## 07 / 30 / 82

↑
FIELD NAME

It is recommended an autodate type field be included on each master form you create. This allows you to monitor when each file record was last updated. The LAST MODIFIED ON field was last updated during a session when the user entered the date 07/30/82.

The Date Type

The date field has a fixed length of eight characters. Any digits 0 through 9 and the blank character can be entered into a date type field. The date you enter in the field has the format you selected (such as MM/DD/YY). Date type fields can contain a different entry for each record in a file. The LAST CONTACTED field on the CLIENTS master form is a date type field:

FIELD
↓

LAST CONTACTED_ ## 07 / 14 / 82

↑
FIELD NAME

Two slashes, decimals, or hyphens (selected during configuration) are provided with each date type field so you don't need to enter them. Only the digits 0 to 9 and the blank character can be entered into a date type field. A single digit for a month or day can be entered where either of the two M's or D's are placed in date type fields. Also, blanks can be used in place of zeros.

Note: When date or autodate fields are printed, blanks replace leading zeros in the month or day positions. If all positions are blank, nothing is printed.

Field Lengths

FILE/80 prompts for the field length only after you have pressed **NEW**, entered a field name (optional), and pressed either **CHAR**, **INTEGER**, **FLOAT**, or **CURRENCY**. When prompted to enter the length of a field, you simply enter the length (as a number) and press **ENDLINE**. If the length you enter is not permitted, a message is displayed giving you the range of acceptable lengths. These lengths are summarized in the **Field Length Table**, page 44. If you're entering the length for an integer, float, or currency field, refer to **Numeric Field Lengths** on page 44.

Note: With long character type fields (formatted or unformatted), it is possible the field itself won't fit on labels you design. Refer to **Converting Dimensions**, page 153, for specific column widths.

If you entered the field name **LAST NAME** and pressed **CHAR**, this screen is displayed. To enter a length of 15, do the following:

Press **1** **5** **ENDLINE**

The screenshot shows a terminal window with the following text:

```

LAST NAME                ** NEW FIELD **                FIELD TYPE: CHARACTER
ENTER THE LENGTH OF THE FIELD 15
  
```

At the bottom of the screen, there is a row of function keys: **F1** APPEAR, **F2** [underline], **F3** [underline], **F4** [underline], **F5** [underline], **F6** ABORT, **F7** [underline].

The following special function keys can be used:

FORM Press this special function key to enter a formatted character field. Instructions are provided under **Formatted Character Fields** on page 46. This special function key is only shown when a character type field is selected.

ABORT By pressing **ABORT**, you can change the type of the field you are defining. When pressed, the screen with the field types in the special function window is displayed.

Numeric Field Lengths

It is recommended you overestimate each numeric field you define by several digits if you plan to take subtotals or grand totals of the field for a report. FILE/80 automatically allows two extra digits. Unless your field with two extra digits is large enough to accommodate the total being accumulated, the result printed on your report will not be correct.

FILE/80 does give you the capability to increase the length of fields on any master form after it has been stored on disc. However, because data may have already been entered into the separate file records this modification can be time-consuming. By choosing field lengths large enough to hold any totals you can anticipate, you avoid the need to modify the length of numeric fields. Details on taking grand totals and subtotals are provided in section 4.

A wide range of field lengths are available for most field types. These lengths are entered as numbers from your HP-86/87 keyboard or numeric keypad. A table of the field types and lengths of FILE/80 follows.

Field Length Table

Field Type	Field Length	Notes
CHARACTER	1 to 50 characters.	Formatting optional.
INTEGER	1 to 12 digits.	—
FLOAT	8 to 19 digits.	Floating, fixed point, exponential.
CURRENCY	3 to 12 digits.	Currency sign, decimal point.
AUTODATE	8 characters, fixed.	Date of last change.
DATE	8 characters, fixed.	—

Note: For more detailed information concerning specific field types, refer to **Field Types** on page 39.

Putting Fields

After selecting a field name, type, and length, the new field appears in the information window of the `NEW FIELD` screen. You use the cursor keys to move the field over the surface of the master form to the desired location. Then you press the `PUT` special function key to place the field on the master form. The line and column counters in the title/feedback window indicate the position of the leftmost character in the field name of the field you are moving.

Fields can be positioned anywhere on the master form except over text or other fields already entered on the master form. If you attempt to put a field over another field or text, the following message is displayed:

```
A new field cannot be put over text or an
already existing field.
```

When this message is displayed, you must use the cursor keys to move the field to another location on the master form or press `ABORT`. Instructions for moving or deleting fields already on the master form are provided later in this section. Instructions for changing text entries are also provided.

To position the field on a portion of the master form that isn't on the screen you move the field to the correct column with `←` or `→`. Then press `↑` or `↓` until the field is on the correct line of the master form. When the field reaches either the first or last line of the information window, the master form scrolls automatically.

This screen is displayed after entering the field length for an unformatted character, integer, float, or currency field. It is also displayed after pressing `AUTODATE` or `DATE`. In this case, the length of 15 for an unformatted character type field has just been entered. The line and column counters indicate that the `L` of `LAST NAME` is on line 11, column 3. This is the location of the `LAST NAME` field on the `CLIENTS` master form. To put the `LAST NAME` field in this location, press `PUT`:

Press `PUT`

The screenshot shows a terminal window titled "NEW FIELD" with the following content:

```

LAST NAME                ** NEW FIELD **                FIELD TYPE: CHARACTER
                        Form line 11 column 3
-----
LAST NAME **
-----
1 PUT  2 _____ 3 _____ 4 _____ 5 _____ 6 ABORT 7 _____

```

The screen is framed by a thick black border. The top line shows the field name "LAST NAME", the title "** NEW FIELD **", and the field type "FIELD TYPE: CHARACTER". The second line shows the current position "Form line 11 column 3". A horizontal line separates the header from the main area. Below the line, the field name "LAST NAME" is followed by "**". At the bottom, a keyboard layout is shown with keys 1 through 7, where key 1 is labeled "PUT" and key 6 is labeled "ABORT".

The following special function keys are provided:

PUT Press this key to place the field on the master form.

ABORT Press this key to change the length of the field selected.

Pressing **PUT** is the final step in defining any field. After **PUT** is pressed, the **CREATE FORMS** screen is displayed. You can add another field to the master form by pressing **NEW** again. Fields already on the master form can be moved or deleted. When the master form is complete, **ACCEPT** can be pressed.

Formatted Character Fields

The choice of a formatted character field is recommended for fields that must contain the digits 0 to 9 in certain positions but aren't needed for calculations. The **ZIP CODE** field on the **CLIENTS** master form is an example of a formatted character field. The **ZIP CODE** field contains numbers in each position. Since formatted character fields are defined character-by-character, different combinations of character and numeric positions can be selected.

When individual records are added to your file, each character entered into a formatted character field is compared with the pattern defined on the following screen. Only the digits 0 through 9 and the blank character can be entered into a numeric position in a formatted character field. If you attempt to enter any other characters, a message is displayed.

After **NEW** is pressed on the **CREATE FORMS** screen, you enter a field name and select a type for the field. When you select the character type, **FILE/80** gives you the option of entering a formatted character field by pressing **APPEAR**. If you press this special function key, the following screen is displayed. The following keys are pressed to enter the appearance of the **ZIP CODE** field on the **CLIENTS** master form:

Press **NUMERIC NUMERIC NUMERIC NUMERIC NUMERIC** **ENDLINE**

```

  ZIP CODE                ** NEW FIELD **                FIELD TYPE: CHARACTER
  ENTER THE APPEARANCE  NNNNN
  :
  :
  1 CHAR  2 NUMERIC  3 _____  4 _____  5 _____  6 ABORT  7 _____
  
```

The following special function keys can be used:

CHAR can be pressed to specify a position in the field that letters, numbers, or other non-control HP-86/87 keyboard characters can be entered into.

NUMERIC can be pressed to specify numeric positions. Only the digits 0 to 9 and the blank character can be entered into a numeric field position.

BLANK can be pressed to clear the formatted character field. The prompt to enter the length of the field is displayed.

After entering the appearance of a formatted character field, press **ENDLINE**. The field can then be put on the master form with the **PUT** special function key.

Note: It is possible that long formatted character fields will not be able to be placed on labels you design. Refer to **Converting Dimensions** on page 153 for the column widths of labels.

Insertion Characters

Formatted character fields can also contain *insertion characters*. These characters are entered directly from the HP-86/87 keyboard and appear the same on each file record. Insertion characters are included in the 50-character maximum length for character type fields.

When individual records are being added to your file, insertion characters are automatically entered into formatted character fields. They do not need to be re-entered when individual records are updated. The following diagram shows the organization of the **ACCOUNT** field on the **CLIENTS** master form.

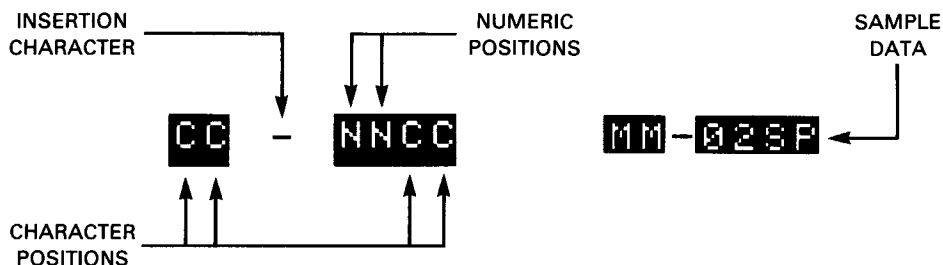

ACCOUNT Field

To enter the appearance for this field, the **NEW** key must first be pressed. After entering the field name **ACCOUNT**, press the **CHAR** special function key. When prompted to enter the field length, press **APPEAR**. Then do the following:

Press **CHAR** **CHAR** **⊖** **NUMERIC** **NUMERIC** **CHAR** **CHAR** **ENDLINE**

```

ACCOUNT                                ** NEW FIELD **                        FIELD TYPE: CHARACTER
ENTER THE APPEARANCE 00-NNNN
ZIP CODE #####
1 CHAR  2 NUMERIC  3      4      5      6 REPORT  7

```

FILE/80 Display

Notice that the insertion character, **-**, is not displayed with inverse video. This is how you can tell insertion characters from the character and numeric positions you specify in a formatted character field. After pressing **ENDLINE**, FILE/80 prompts you to position the field on the master form. After pressing **PUT**, the **CREATE FORMS** screen is displayed.

Moving Fields

Moving fields already entered on the master form is simple. You move the field over the surface of the master form with the cursor keys. First, you press **MOVE** on the **CREATE FORMS** screen. This special function key is displayed when at least one field has been placed on the master form.

Next, you press **ENDLINE** to move the cursor over the field you want to move. The field name the cursor is over is displayed in the title/feedback window of the **MOVE FIELD** screen. The name of the field the cursor is on is also displayed with inverse video in the information window. The cursor moves to the next field each time **ENDLINE** is pressed. If you hold **SHIFT** down and press **ENDLINE**, the cursor moves to the previous field.

When the field you wish to move is not displayed in the information window, you can press **CONT** to scroll the master form 15 lines forward. By holding **SHIFT** and pressing **CONT** the master form scrolls in the reverse direction.

When the cursor is over the field you want to move, press **PICK**. If you accidentally press **PICK** when the cursor is over a field you don't wish to move, immediately press **PUT**—the field will remain in the same location.

After picking the field, use the cursor keys to move the field to the desired location on the master form. When the field is in the correct location, press **PUT**. The field you choose to move can be put anywhere on the master form except where other fields or text have already been placed.

Deleting Fields

After placing several fields on the master form, you might want to remove one. To remove a field, press the **DELETE** special function key on the **CREATE FORMS** screen. Next, position the cursor over the field you want to delete. The cursor moves to the next field each time you press **END LINE**. Hold down **SHIFT** and press **END LINE** to move the cursor to the previous field. After you have positioned the cursor over the field you want to remove, press **PICK**. The field you selected is removed from the master form.

Text

You can enter text on the master form whenever the **CREATE FORMS** screen with the **NEW** special function key is displayed. Any alphanumeric character can be entered from your HP-86/87 keyboard. Text can also be removed when the **CREATE FORMS** screen is displayed. All characters entered as text are treated separately. You cannot move text entries with the cursor keys. To be moved, text must be removed and then re-entered.

- To enter text, simply position the cursor over the location text is to be entered. Type in the characters from the keyboard. This text appears exactly the same for each record in your file.
- To remove text, position the cursor over the characters you wish to remove. Then press **SPACE BAR** or **BACK SPACE** until it has all been erased.

A maximum of 4,800 characters of text can be placed on the master form.

Key Selection

Keys are fields used for organizing file records in an addressable order. The information you enter in key fields provides a means of accessing records quickly. Files are organized alphabetically, numerically, or chronologically depending on the field type. The use of key fields enables the ordering of letters, labels, or records in a report without sorting. This saves time when producing output.

There are two types of keys: primary and secondary. FILE/80 requires a primary key for each file. The primary key can consist of up to four separate fields. The speed of record access depends on the combined length of these fields. The shorter the primary key, the more quickly records can be accessed.

Up to four fields on the master form can be designated as secondary keys. Although these keys are optional, they allow you to access records very quickly. Any field on the master form can be used to retrieve a record, but those fields you anticipate using frequently for accessing records are good candidates for secondary keys.

The Primary Key

FILE/80 offers you the choice of unique or non-unique primary keys. With a non-unique primary key, records with duplicate primary keys can be added to a file. A unique primary key requires that the information entered into it will be unique for each file record. The combined lengths of the primary key fields cannot exceed 50 character equivalents. Refer to page 55 for converting field lengths to character equivalents.

The primary key for the CLIENTS file, stored on the FILE/80 Demonstration Disc, is designated as unique and consists of three fields. These are the **CLASSIFICATION**, **ACCOUNT**, and **PROJECT** fields. For many records, entries in the **CLASSIFICATION** and **ACCOUNT** fields are the same. Since the **PROJECT** field is different for each file record, the combined data in the primary key fields is unique.

	CLASSIFICATION	ACCOUNT	PROJECT
Unique Keys	01-CS	MM-02SP	0206
	01-CS	MM-02SP	0207
Duplicate Keys	03-GI	JS-09SM	0902
	03-GI	JS-09SM	0902

With a primary key that is designated as unique, you cannot add a record with primary key field entries that duplicate the primary key field entries of a record already in the file. The record cannot be added because it does not have a unique primary key. Refer to section 7, **Changing Master Forms**, to change primary key designations after a file has been created.

Secondary Keys

Secondary keys are optional. The CLIENTS file uses the ZIP CODE and LAST NAME fields as secondary keys. This allows quick access and displaying of records when a client's last name is entered. When the sample letters and mailing labels for the CLIENTS file (shown in the overview) are printed, they are arranged by the ZIP CODE field. Because this field is a secondary key for the CLIENTS file, no sorting is actually required when this output is produced.

Designating Keys

To designate either primary or secondary key fields, press **KEYS** on the CREATE FORMS screen. This special function key only appears after at least one field has been defined on the master form and **ACCEPT** has been pressed.

Press **KEYS**

```

FILE NAME: SAMPLE          ** CREATE FORMS **          PASSWORD:
-----
ACCOUNT ***-**-NNNN          CHANEY, MANN, AND HILL          PHONE ***(<NNN>) NNN-NNNN
                               Consulting Engineers
CLIENT QUICK REFERENCE FILE

LAST MODIFIED ON ***/**/**
LAST NAME ***
FIRST NAME ***
MIDDLE INITIAL ***
COMPANY ***

1 NAME  2 PASSWORD 3 FORM  4 KEYS  5 _____ 6 EXIT  7 _____

```

FILE/80 Display

The next screen is used to select keys for your file. To designate the primary key as unique, press **UNIQUE**. With the cursor on the ACCOUNT field, **PRIMARY** can be pressed to select it as a primary key field. Numbers are displayed in the key indicators of any fields designated for the primary key. These numbers indicate the ordering of the fields—up to four can be designated. Depending on the order of fields in the primary key, a **1**, **2**, **3**, or **4** is displayed.

Press **UNIQUE PRIMARY ACCEPT**

```

ACCOUNT          ** SELECT KEYS **          UNIQUE PRIMARY KEY
PRIMARY 1 ACCOUNT

-----
ACCOUNT: 1234-5678          PHONE: 999 (604) 555-1234
                                CHANEY, MANN, AND HILL
                                Consulting Engineers
                                CLIENT QUICK REFERENCE FILE

LAST MODIFIED ON: 12/12/88
LAST NAME:  ██████████
FIRST NAME:  ██████████
MIDDLE INITIAL:  ████
COMPANY:  ████████████████████████████████████████

1 PRIMARY  2 SECOND  3 UNDO  4 _____  5 UNIQUE  6 _____  7 ACCEPT

```

FILE/80 Display

To select keys, just move the cursor over the desired field by pressing **ENDLINE** or **SHIFT ENDLINE**. Then designate the keys for your file by pressing the appropriate special function key:

PRIMARY Press this key to add the field the cursor is currently over to the list of primary key fields displayed in the title/feedback window.

SECOND Press this key to designate the field the cursor is over as a secondary key. Secondary key fields are identified by an **S** in the key indicator unless the field is designated as a primary key.

UNDO Press this key to clear primary or secondary key fields. The location of the cursor determines the field that keys are removed from. If the field cleared is a primary key, the order of the remaining primary keys is shown in the title/feedback window.

UNIQUE Press this key to designate the primary key as unique or non-unique. The designation displayed in the title/feedback window when **ACCEPT** is pressed will be used for your file.

ACCEPT Press **ACCEPT** to use the primary and secondary key fields indicated for your file. The **CREATE FORMS** screen is then displayed.

After designating your primary and secondary key fields, press **ACCEPT**. When the **CREATE FORMS** screen is displayed, note the **DONE** special function key.

File Size

The last step in creating a master form is entering the number of records needed for your application. This is the maximum number of records you'll be able to add to the file after it is stored on disc. It is recommended that you overestimate the size of your file by at least 10 percent. FILE/80 does let you change the size of a file after it has been stored on disc, however. So if you anticipate a file being at all dynamic, it is recommended that you not use the disc(s) it is stored on for any other files. The maximum file size that can be entered is 65,000 records.

To enter the file size, you must first press **DONE** on the CREATE FORMS screen. Before pressing **DONE**, verify that all the discs for storing the created file are in drives on-line. When **DONE** is pressed, the following screen is displayed. To enter a file size of 33 records, press the following keys:

Press (3) (3) (END LINE)

```

** CREATE FORMS **
ENTER THE MAXIMUM NUMBER OF RECORDS IN THE FILE 33
1 _____ 2 _____ 3 _____ 4 _____ 5 _____ 6 ABORT 7 CONFIGURE

```

FILE/80 Display

After the file size has been entered, FILE/80 displays a tentative arrangement of necessary disc files (shown on the next screen). Before files are stored, FILE/80 automatically packs the discs that files are to be stored on. If the disc space on-line is not sufficient for storing the needed files, a message is displayed giving the maximum records that can be stored.

To reduce the size of files needed for an application, several steps can be taken. The maximum number of records can be reduced. The (SPACE BAR), (^{BACK}SPACE), (←), and (→) keys can be used to change the number. By pressing **ABORT**, you can remove fields from the master form. Or, you can press **CONFIGURE** to execute mass storage commands—you could purge unneeded files or initialize another disc, for example. Refer to section 8 for more information.

The files shown on the next screen are needed to support your application and should not be tampered with. All of these disc files need to be on-line whenever accessing your file. Press **ACCEPT** on this screen to store the master form on disc.

Press **ACCEPT**

```

                ** CREATE FORMS **                FILE SIZE: 33 RECORDS
Please select a special function key.
-----
FILE NAME      VOLUME NUMBER  VOLUME NAME  NUMBER OF RECORDS
SAMPLE_R      :0701          _____
SAMPLE_A      :0701          _____
SAMPLE_1      :0701          _____
                33
-----
1 _____ 2 _____ 3 _____ 4 _____ 5 _____ 6 ABORT 7 ACCEPT

```

FILE/80 Display

You can press **ABORT** if you don't like the arrangement of files shown or want to change the file size. The screen with the prompt to enter the file size is displayed. An explanation of the files on this screen is presented in section 9. With large files, the last files (ending with _1, _2, ...) are stored on several volumes. These files are used for storing the entries you make on file records.

After all the files are stored on disc, this screen is displayed. You can press **EXIT** to end the session and return your HP-86/87 to calculator mode. The use of the **FILE/80** screen is covered in remaining sections of this manual.

Press **EXIT**

```

                ** FILE/80 **                FILE SIZE: 33 RECORDS
Please select a special function key.
:
:
1 QUERY  2 OUTPUT  3 REDEFINE  4 TABS  5 DEFAULTS  6 EXIT  7 DONE

```

FILE/80 Display

Character Length Equivalents

Field Type	Conditions	Character Equivalents (Bytes)
AUTODATE	—	6, fixed.
CHARACTER	APPEARANCE not pressed.	Same as field length.
	APPEARANCE pressed.	Number of C s + S s.
DATE	—	6, fixed.
CURRENCY	Length entered:	
	3	2
	4	2
	5	3
	6	3
	7	4
	8	4
	9	4
	10	5
	11	5
12	6	
INTEGER	—	8, fixed.
INTEGER	Length entered:	
	1	1
	2	1
	3	2
	4	2
	5	3
	6	3
	7	4
	8	4
	9	4
	10	5
	11	5
12	6	

CLIENTS Master Form Entries

The following fields and text are present on the CLIENTS master form, stored on the FILE/80 Demonstration Disc. You can make these entries on your own SAMPLE master form. The primary and secondary keys, as well as the file size are also indicated.

The following listing of fields is printed when **DUMP FILE** is pressed on the **OUTPUT** screen when the **CLIENTS** file is being accessed.

Master Form Summary for: CLIENTS					
Current Number of Recs: 30			Maximum Number of Recs: 33		
KEY	FIELD NAME	TYPE	LENGTH/APPEARANCE	LINE	COL.
25	ACCOUNT	Formatted	CC-NNCC	1	3
	PHONE	Formatted	(NNN) NNN-NNNN	1	59
	LAST MODIFIED ON	Autodate	8 characters	9	3
S	LAST NAME	Character	15 characters	11	3
	FIRST NAME	Character	15 characters	13	3
	MIDDLE INITIAL	Character	1 character	15	3
	COMPANY	Character	30 characters	17	3
	ADDRESS 1	Character	30 characters	19	3
	ADDRESS 2	Character	30 characters	21	3
	CITY/STATE	Character	30 characters	23	3
S	ZIP CODE	Formatted	NNNNN	25	3
	ACCOUNT REP	Character	10 characters	28	3
	HOURS LOGGED	Integer	3 digits	30	3
	LAST CONTACTED	Date	8 characters	32	3
3	PROJECT	Formatted	NNNN	34	3
1	CLASSIFICATION	Formatted	NN-CC	36	3
	CONSULTING REQUIREMENTS	Character	42 characters	39	3
	PROFITABILITY INDEX	Float	8 digits	41	3
	PROJECT FROM	Date	8 characters	45	3
	TO	Date	8 characters	45	27
	TOTAL HOURS ALLOTTED	Integer	6 digits	47	3
	CLIENT SINCE	Date	8 characters	49	3
	TOTAL AMOUNT PAST DUE	Currency	10 digits	52	3
	YTD BUSINESS VOLUME	Currency	12 digits	52	43
	AMOUNT PAID THIS MONTH	Currency	10 digits	54	3
	YTD CONSULTING HOURS	Integer	9 digits	54	43
	RATE SCHEDULE 1	Currency	5 digits	57	3
	HOURS THIS MONTH 1	Integer	3 digits	57	43
	RATE SCHEDULE 2	Currency	5 digits	59	3
	HOURS THIS MONTH 2	Integer	3 digits	59	43

The text entries on the CLIENTS master form are listed with the position of the leftmost character:

Text	Line	Col.
CHANEY, MANN, AND HILL	2	30
Consulting Engineers	3	31
CLIENT QUICK REFERENCE FILE	5	27
MONTHLY	30	22
1. Subtract TOTAL AMOUNT PAST DUE from YTD BUSINESS VOLUME.	42	3
2. Divide difference obtained by YTD BUSINESS VOLUME.	43	3

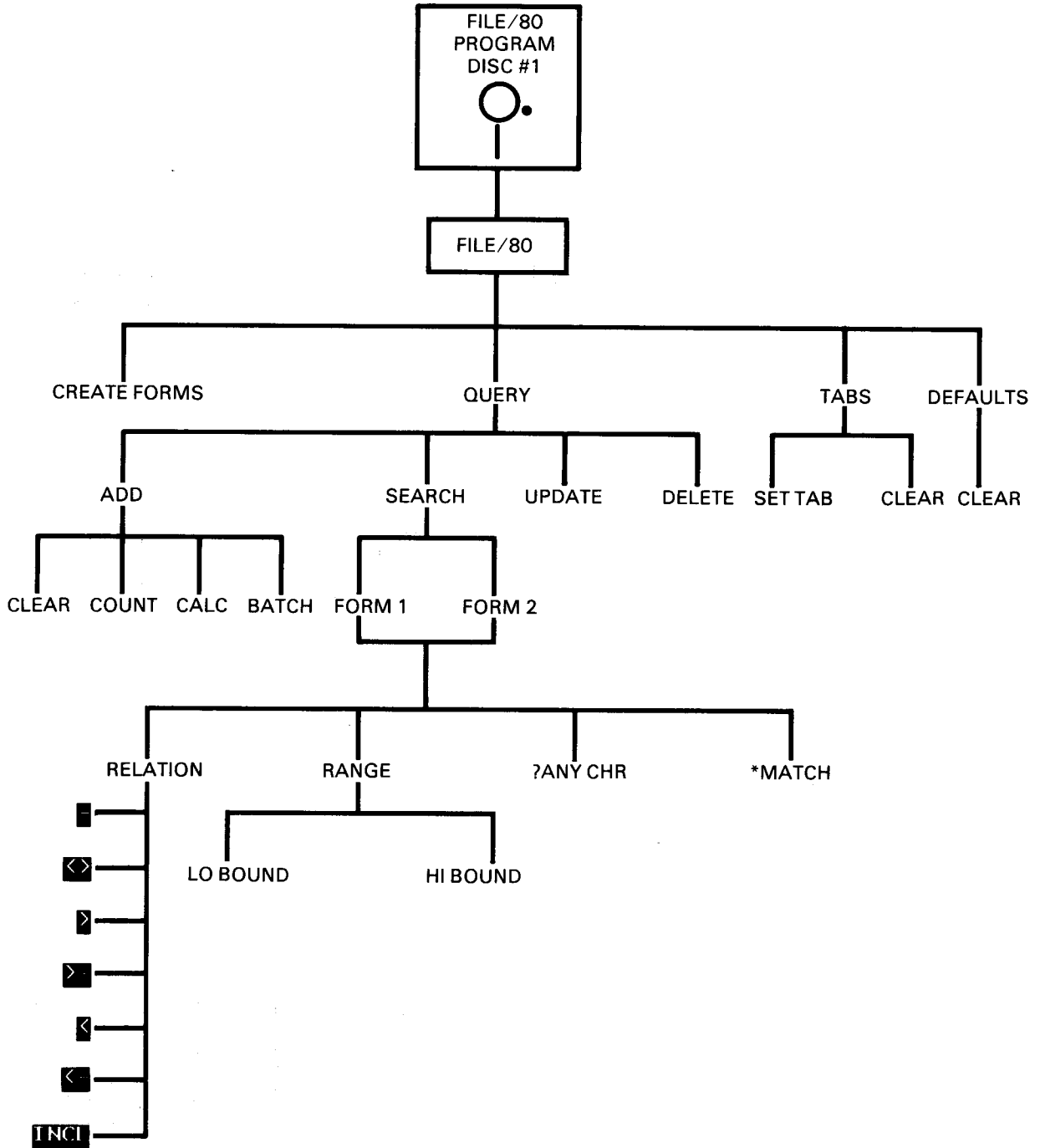

QUERY Diagram

Accessing Your Records

Introduction

In this section, the use of the `QUERY` screen is covered. This screen is used to access individual records in your file and to add, update, or delete records. Before records can be changed, you access them with the `SEARCH` screen.

`FILE/80` offers a choice of several methods for retrieving records in your file. In each case you supply data in fields of the master form and then access records with similar information. You can retrieve single records or groups of records for updating or displaying on the screen.

Note: The examples in this section require the use of `FILE/80` Program Disc #1 and the `FILE/80` Demonstration Disc.

WARNING

It can be necessary to change the program media (flexible discs) while the `FILE/80` program is running. `FILE/80` will prompt you whenever a media change is required. **DO NOT CHANGE MEDIA WITHOUT BEING INSTRUCTED TO DO SO.** Changing media, opening disc drive doors, or turning a disc drive off without being prompted to can result in corruption of your files and possible loss of data. Pressing `RESET` twice while the program is running can have the same consequences.

Not all the program segments stored on the `FILE/80` Program Discs are loaded into your `HP-86/87` simultaneously. When the `FILE/80` program is running, different program segments are automatically loaded when they are needed. When this occurs, a message is displayed on the screen explaining that the system is busy. Wait until the loading process is finished. If the `FILE/80` Program Disc containing the needed segment is not on-line, then a message instructs you to insert a specific `FILE/80` Program Disc by its number (1, 2, 3, or 4). The name of the program segment is also provided.

File Access

To access a file already stored on disc, load the `FILE/80` program according to these instructions:

- a. Connect disc drives to your computer in the proper manner.
- b. Apply power to all devices connected to your computer.
- c. Turn your computer on.
- d. Insert `FILE/80` Program Disc #1 into the default MSUS of `:0700` and the `FILE/80` Demonstration Disc into MSUS `:0701`. Make sure the disc drive doors are closed.

- e. Enter the following command and press **END LINE**.

```
LOAD "FILE/80"
```

- f. Press the **RUN** key.
- g. When the **WELCOME TO FILE/80** message appears, press **OLD FILE**.

File Name and Password

After pressing **OLD FILE**, FILE/80 asks you for the name of your file. If you're accessing the file **CLIENTS**, for example, simply enter the file name **CLIENTS** and press **END LINE**.

FILE/80 now checks to see that a disc file with the characters **_R** appended to the file name you entered is in a drive connected to your HP-86/87. If this file isn't on-line, the following message will be displayed:

```
ENTER THE MSUS OF THE DISC WHERE CLIENTS_R
IS LOCATED ":D[REDACTED]"
```

If your file has a password, you are requested to enter it. To access the **CLIENTS** file, the password is **HP**. Press **END LINE** after entering the password.

After your file has been accessed, FILE/80 requests the current date. Enter it and press **END LINE**.

Verifying Peripherals

After the current date has been entered, FILE/80 displays the following screen. Check the printer address and each MSUS to verify the data is correct. The MSUS of each drive where the FILE/80 program discs and your file discs are located need to be included. If the data is correct and complete, press **ACCEPT**.

Press **ACCEPT**

```
FILE NAME: CLIENTS          ** FILE/80 **          TODAY'S DATE: 02-13-88
                                                                    PRINTER IS: 734
```

Please make corrections to the list of mass storage unit specifiers.

```

001 EE ON-LINE          002 EE ON-LINE
      ":D700"          " :D701"

```

```

1. NEW      2. _____  3. _____  4. DELETE  5. PRINTER  6. _____  7. ACCEPT

```

FILE/80 Display

If the data is not correct, you can change the printer address or update the MSUS table.

- Press **DELETE** to remove incorrect MSUSs from the table. When pressed, FILE/80 prompts you for the MSUS you wish to remove. Enter the digits on the screen and press **(END LINE)**.
- To add an MSUS to the table, press **NEW**. FILE/80 prompts you to enter the digits of the new MSUS. Enter them and press **(END LINE)**.
- Press **PRINTER** to change the printer address. When the prompt appears, enter the correct address and press **(END LINE)**.
- When the data is complete and correct, press **ACCEPT**.

After **ACCEPT** is pressed, the following screen is displayed. This screen enables you to add records to or retrieve records from your file. After they are displayed, records already in your file can be updated or deleted.

```

FILE NAME: CLIENTS          ** FILE/80 **          TODAY'S DATE: 03 13 83
Please select a special function key.

1 QUERY  2 OUTPUT  3 RECEIVING  4 TABS  5 DEFAULTS  6 EXIT  7 DONE

```

FILE/80 Display

The following special function keys can be used when accessing your file records:

QUERY Press this key to add or retrieve records in your file.

TABS Press this key to set or clear tab stops on fields of the master form.

DEFAULTS Press this key to automatically enter values into blank fields on records that are being added to your file.

EXIT Press this key to exit the FILE/80 program.

DONE Press this key to access another file—the screen with the **NEW FILE** and **OLD FILE** special function keys is displayed.

Adding Records

Records are added to your file with the **ADD** screen. To display this screen, press **QUERY**. When the **QUERY** screen is displayed, press **ADD**. This screen is displayed:

```

** ADD **

ACCOUNT# ***-
                                CHANEY, MANN, AND HILL
                                Consulting Engineers
                                CLIENT QUICK REFERENCE FILE

                                PHONE_#< > -

LAST MODIFIED ON_ ##/##/##
LAST NAME_#*#
FIRST NAME_#*#
MIDDLE INITIAL_#*#
COMPANY_#*#

1 CLEAR  2 COUNT  3 _____  4 BATCH  5 _____  6 ABORT  7 ACCEPT

```

FILE/80 Display

The following special function keys provide features to help you add records both easily and accurately. After **ACCEPT** is pressed, the **QUERY** screen is displayed. You can press **SEARCH** to retrieve the record you just added.

CLEAR Press this key to “blank out” all the fields on the file record you are adding. Information is removed from all fields except those that are autodate.

COUNT Press this key to check the number of records currently in your file. This is the number of records out of the maximum available that are being used to store file records.

CALC Press this key to perform calculations on numbers you enter in numeric fields. This key is only displayed when the cursor is over a numeric field. Instructions for doing these calculations are provided shortly.

BATCH Press this key to add another record to your file. The record currently on the screen is stored in your file and then a blank form is provided so another record can be added. Instructions for adding multiple records follow.

ABORT Press this key to throw away any information you just entered in the record currently displayed on the **ADD** screen. The **QUERY** screen is then displayed.

ACCEPT Press this key to add the form currently displayed in the information window to your file. The **QUERY** screen is then displayed.

To add a record, you just enter information in the fields on the blank copy of the master form. After you enter the information in each field, press **END LINE**. You can't move the cursor off a field until valid information has been entered in it. Only the digits 0 through 9 and blanks can be entered into numeric positions of the formatted character fields, for example.

To enter information into different fields you can press **END LINE** to move the cursor to the correct field. Information is entered into whichever field the cursor is over. If you have set up tabs, you can use **CONT** to move the cursor to the next tab field. By holding down **SHIFT** and pressing either **CONT** or **END LINE**, the cursor is moved in the opposite direction.

After entering information in the fields of the form, press **ACCEPT** to add the record on the screen to your file. If you have specified a unique primary key and the primary key fields on the form match those of a record already in your file, a message is displayed. In this case you must change the primary key fields so they are unique before a record can be added to your file.

Note: You cannot position the cursor over any autodate type fields. This is because autodate fields are automatically updated by FILE/80 whenever a record is added or modified. When you add a record, the date entered at the beginning of the session is automatically entered in any autodate fields.

Instructions for Using CALC

The **Ctrl C** special function key allows you to use your HP-86/87 like a calculator when the cursor is over a numeric field. Addition, subtraction, multiplication, and division operations can be performed.

- a. Position the cursor over the numeric field you want the final result in. This can be done with **END LINE**.
- b. Enter the first number of the calculation in the field. Do *not* press **END LINE**. If necessary, use **BACK SPACE** for editing this entry.
- c. Press **Ctrl C**.
- d. FILE/80 requests you to enter an operator. Press **+**, **-**, *****, or **/**. The operator you enter appears where the search/sort indicator is usually displayed.
- e. After you have entered the operator, FILE/80 requests you to enter the second number of the calculation. Enter this number from your keyboard. It replaces the first number you entered. You can use **BACK SPACE** to edit the entry.
- f. Press **=**. FILE/80 displays the result of the calculation in the field.
- g. To enter the number into the field, press **END LINE**.

How to Use BATCH

The **BATCH** special function key is pressed to add several records to your file. After you enter information into fields on the form, press **BATCH** to add the record to your file. **FILE/80** adds the record to your file and presents another blank form on the **ADD** screen.

- a. Press **QUERY** on the **FILE/80** screen.
- b. Press **ADD** on the **QUERY** screen.
- c. Make entries on the blank form displayed in the information window of the **ADD** screen.
- d. Press **BATCH**. The record you entered in step c is added to your file.
- e. **FILE/80** displays a blank form in the information window of the **ADD** screen.
- f. Repeat steps c through d until all but one of the records being added to your file have been entered.
- g. Enter the data for the last record.
- h. Press **ACCEPT**. **FILE/80** displays the **QUERY** screen.

Entering Information Into Fields

Character Fields

When you respond to prompts in the title/feedback window, you are making character type entries. Mistakes can be corrected by pressing **SPACE BAR**, **BACK SPACE**, **←**, or **→**. When you enter information into character type fields on a form, the same keys can be used to correct entries. Always check to see if the entry is what you intended before pressing **END LINE**. The same procedure should be used with date fields.

Numeric Fields

Entering digits into integer, currency, or float fields works differently. When the cursor is over a numeric field, it remains over the digit on the right end of the field. Also, **BACK SPACE** is the only key that can be used to correct digits entered into numeric fields. When you press **BACK SPACE**, all the digits to the left of the cursor move one space to the right. If the first digit entered in a numeric field is wrong, the entire number must be “backed out” of the field so that the first digit is under the cursor, where it can be corrected. Always check numeric entries before pressing **END LINE**.

Setting Defaults

Defaults are entered to make the addition of multiple records with identical information in some fields easier. If you set defaults, whenever you press **ADD** to add a record, the last values entered on the **DEFAULTS** screen are automatically entered into the fields of the form on the **ADD** screen. To enter defaults for adding records, press **DEFAULTS** on the **FILE/80** screen. This screen is displayed:

```

** DEFAULTS **

ACCOUNT_###-###-###          CHANEY, MANN, AND HILL          PHONE_###(###)###-###
                             Consulting Engineers
                             CLIENT QUICK REFERENCE FILE

LAST MODIFIED ON_###/###/###
LAST NAME_###
FIRST NAME_###
MIDDLE INITIAL_###
COMPANY_###

1 CLEAR  2 _____  3 _____  4 _____  5 _____  6 _____  7 ACCEPT

```

FILE/80 Display

To enter a default value, move the cursor over the desired field by pressing **END LINE** and enter the value you want. Defaults can be entered into any fields except autodate type fields. The following special function keys can be used.

CLEAR Press this key to reset all the fields on the default form to blanks or zeros.

ACCEPT Press this key to set the defaults currently entered on the form.

When all the default values have been entered, press **ACCEPT**. The FILE/80 screen you pressed **DEFAULTS** on is displayed. When you add a record, the defaults you just set are automatically entered into the fields of the form on the **ADD** screen.

Setting Tabs

Tabs can be set on up to 10 fields on the master form. When tabs have been set, you can move the cursor to tab fields by pressing **CONT** or **SHIFT CONT**. The use of tabs is optional. Tabs are provided as a convenience when adding, retrieving, or modifying records in your file. Once a tab has been set, FILE/80 programs the cursor to only stop at fields you select with the **SET TAB** special function key when **CONT** is pressed.

You can tab forwards by pressing **(CONT)**, or tab backwards by holding down **(SHIFT)** while pressing **(CONT)**. If the field you're tabbing to is not currently displayed in the information window, the form displayed is scrolled so it becomes visible. Regardless of the order you set them in, the cursor moves to tab fields from left to right and top to bottom on the master form when **(CONT)** is pressed.

To set tabs, press the **TABS** special function key on the **FILE/80** screen. The following screen is displayed. To set tabs you use **(END LINE)** or **(SHIFT) (END LINE)** to move the cursor over the field you want a tab stop for and press **SET TAB**.

```

** TABS **

ACCOUNT_***[REDACTED]
                                CHANEY, MANN, AND HILL
                                Consulting Engineers
                                PHONE_***[REDACTED]
                                CLIENT QUICK REFERENCE FILE

LAST MODIFIED ON_**[REDACTED]
LAST NAME_**[REDACTED]
FIRST NAME_**[REDACTED]
MIDDLE INITIAL_**[REDACTED]
COMPANY_**[REDACTED]

1 SET TAB  3 CLEAR  2 [REDACTED]  4 [REDACTED]  5 [REDACTED]  6 [REDACTED]  7 ACCEPT

```

FILE/80 Display

These special function keys are provided:

SET TAB Press this key to designate the field the cursor is on as a tab stop. Once a field has been selected as a tab stop, the field name is displayed with inverse video on the **TABS** screen.

CLEAR Press this key to remove a tab stop that might be set for the field the cursor is over. If a field is not a tab stop, the field name is only displayed with inverse video when the cursor is placed on it.

ACCEPT Press **ACCEPT** when all the tab stops entered on the form are set correctly.

Before pressing **ACCEPT**, you can press **(CONT)** to tab to the next field designated as a tab stop on the blank form. Hold down **(SHIFT)** and press **(CONT)** to move the cursor to a previous tab stop.

After **ACCEPT** is pressed, the **FILE/80** screen is displayed. If you retrieve a record from your file or add a record, you can press **(CONT)** or **(SHIFT) (CONT)** to move the cursor to tab fields on the file record.

These four fields of the CLIENTS file, stored on the FILE/80 Demonstration Disc, are designated as tab stops:

- ACCOUNT
- HOURS LOGGED
- PROJECT
- YTD BUSINESS VOLUME

These fields are located on lines 1, 30, 34, and 52, respectively, of the CLIENTS master form.

Record Access

To access records already stored in your file, press the **QUERY** special function key on the FILE/80 screen. This **QUERY** screen is shown. To access individual records in your file, you press the **SEARCH** special function key:

Press **SEARCH**

```

** QUERY **

Please select a special function key.

1. ACC 2. SEARCH 3. 4. 5. 6. 7. DONE

```

FILE/80 Display

After you locate individual file records with the **SEARCH** screen, they are displayed on the **QUERY** screen. Whenever an actual file record is displayed on this screen, you can press **(LIST)** to print a copy of it. If more than one record is located with the **SEARCH** screen, pressing **(PLST)** prints copies of all records satisfying the search.

Before any records have been located, the **NEXT**, **PREVIOUS**, **UPDATE**, and **DELETE** special function keys are not displayed on the **QUERY** screen. The information window is blank since no records have been retrieved from your file. The **(LIST)** and **(PLST)** keys are also disabled since no record is in the information window.

Comparison of Field Entries

Unformatted Character Fields

When records are located in a file, groups of records that satisfy certain conditions are often retrieved. If you are comparing information in unformatted character type fields, the following rules are used:

- The digits 0 to 9 are considered “less” than the characters A to Z.
- Differences in capitalization are not recognized.
- Multiple blanks between words are treated as a single blank.
- Leading and trailing blanks are not observed.

Formatted Character Fields

- The digits 0 to 9 are considered “less” than the characters A to Z.
- Differences in capitalization are not recognized.
- All blanks are considered significant.

Numeric Fields

When numeric entries are compared with integer, currency, or float fields, the *value* of the field is compared.

Date Fields

Earlier dates are considered less than more recent dates.

Locating File Records

The `SEARCH` screen is used to locate records in your file. There are many ways to retrieve specific records and display them in the information window. The `SEARCH` screen is shown below. This is the screen displayed when `SEARCH` is pressed on the `QUERY` screen.

```

** SEARCH **

ACCOUNT_###-###          CHANEY, MANN, AND HILL          PHONE_###(###)###-###
                          Consulting Engineers
                          CLIENT QUICK REFERENCE FILE

LAST MODIFIED ON_##/##/##
LAST NAME_###
FIRST NAME_###
MIDDLE INITIAL_###
COMPANY_###
1. RELATION 2. RANGE 3. COMPANY CHR 4. MATCH 5. FORM 2 6. ABORT 7. ACCEPT

```

FILE/80 Display

With this screen and the special function keys it provides, you can specify up to 10 search conditions. This is done by entering information in fields on the form displayed and pressing different combinations of special function keys. The special function keys **RELATION** and **RANGE** provide their own special function windows.

The entries you make on the form determine which records FILE/80 locates in your file and displays in your information window. If you don't make any entries on the form and press **ACCEPT**, every file record becomes available. These records are ordered by the primary key fields. For the CLIENTS file, this is the same order of records in the PROJECT SUMMARY REPORT. When **ACCEPT** is pressed on the SEARCH screen, this QUERY screen is displayed.

```

** QUERY **

Please select a special function key.
-----
ACCOUNT_**09-1390          CHANEY, MANN, AND HILL          PHONE_**(<317> 555-8218
                        Consulting Engineers
                        CLIENT QUICK REFERENCE FILE

LAST MODIFIED ON_**05/28/88
LAST NAME_**Robinson
FIRST NAME_**Liff
MIDDLE INITIAL_**
COMPANY_**Robinson-Douglas Inc.

1 ADD 2 SEARCH 3 NEXT 4 _____ 5 UPDATE 6 DELETE 7 DONE

```

FILE/80 Display

Only the **PREVIOUS** special function key is not displayed at first. When you press **NEXT**, FILE/80 searches to see if any other records match the conditions you specified. If there is another match, the next record is displayed and the **PREVIOUS** special function key appears. If no search conditions were originally entered, then the next record in the file (according to the primary key) is displayed. The **UPDATE** and **DELETE** special function keys are explained later in this section.

Finding Records With Relation

Any information can be entered on the form displayed in the information window of the **SEARCH** screen. This information can be complete, or it can be just part of the entry on the file record you are trying to locate. For example, you can locate all records in the **CLIENTS** file with an amount of \$100.00 or greater in the **TOTAL AMOUNT PAST DUE** field. First press **(CONT)** three times and then press **(SHIFT) (ENDLINE)** to position the cursor over the **TOTAL AMOUNT PAST DUE** field. When the cursor is over this field, enter the number 100.00 and press **RELATION**:

Press **10000** **RELATION**

```

** SEARCH **

2. Divide difference obtained by YTD BUSINESS VOLUME.
PROJECT FROM_###/##/## TO_###/##/##
TOTAL HOURS ALLOTTED_###
CLIENT SINCE_###/##/##

TOTAL AMOUNT PAST DUE_###$100.00 YTD BUSINESS VOLUME_###$.##
AMOUNT PAID THIS MONTH_###$.## YTD CONSULTING HOURS_###

RATE SCHEDULE 1_###$.## HOURS THIS MONTH 1_###
RATE SCHEDULE 2_###$.## HOURS THIS MONTH 2_###

1 RELATION 2 RANGE 3 _____ 4 _____ 5 FORM 6 ABORT 7 ACCEPT
    
```

FILE/80 Display

When **RELATION** is pressed, this screen is displayed. To retrieve all records that have the amount of \$100.00 or greater in the **TOTAL AMOUNT PAST DUE** field, press **>=**:

Press **>=**

```

** SEARCH **

Please select a search relation from the special function keys.

2. Divide difference obtained by YTD BUSINESS VOLUME.
PROJECT FROM_###/##/## TO_###/##/##
TOTAL HOURS ALLOTTED_###
CLIENT SINCE_###/##/##

TOTAL AMOUNT PAST DUE_###$100.00 YTD BUSINESS VOLUME_###$.##
AMOUNT PAID THIS MONTH_###$.## YTD CONSULTING HOURS_###

RATE SCHEDULE 1_###$.## HOURS THIS MONTH 1_###
RATE SCHEDULE 2_###$.## HOURS THIS MONTH 2_###

1 = 2 _____ 3 _____ 4 = 5 _____ 6 = 7 _____
    
```

FILE/80 Display

The original set of SEARCH special function keys is displayed after you press **>=**. Press **ACCEPT** to locate any records in the CLIENTS file with an amount of \$100.00 or greater in the TOTAL AMOUNT PAST DUE field. Next, FILE/80 displays messages in the title/feedback window indicating that a search is underway. An **ABORT** key is provided in the special function window for the duration of the search. It can be pressed to discontinue a search.

If there are any records matching the condition you specified, the first one is displayed in the information window. For the CLIENTS file this record is displayed. The entry in the TOTAL AMOUNT PAST DUE field is \$135.00

```

** QUERY **

Please select a special function key.
-----
2. Divide difference obtained by YTD BUSINESS VOLUME.
PROJECT FROM_***06/01/82 TO_***06/06/82
TOTAL HOURS ALLOTTED_***          ?
CLIENT SINCE_***03/14/79

TOTAL AMOUNT PAST DUE_***$ 135.00   YTD BUSINESS VOLUME_***$ 210.00
AMOUNT PAID THIS MONTH_***$ 135.00 YTD CONSULTING HOURS_***          ?

RATE SCHEDULE 1_***$ 20.00         HOURS THIS MONTH 1_***          ?
RATE SCHEDULE 2_***$ 45.00         HOURS THIS MONTH 2_***          ?

1 ADD 2 SEARCH 3 NEXT 4        5 UPDATE 6 DELETE 7 DONE

```

FILE/80 Display

To see if any other records satisfy the conditions specified for the search, press **NI X1**. Another search occurs. If you press **ABORT** while a search is underway, the SEARCH screen is displayed. You can change the conditions of the search and restart it by pressing **ACCEPT**, or press **ABORT**. For example, the entry in the TOTAL AMOUNT PAST DUE field could be changed to \$50.00. If **ACCEPT** is pressed, another search begins. When no records match the conditions of the search, a message is displayed in the title/feedback window of the SEARCH screen. If you do not wish to enter any other search conditions, you can press **ABORT** to display the QUERY screen.

Use of INCL

FILE/80 lets you retrieve records with a particular sequence of characters or digits in character fields (formatted or unformatted) with the **INCL** special function key. To search for records that contain the character sequence **CONCRETE** in the **CONSULTING REQUIREMENTS** field of the **CLIENTS** file, you first press the **SEARCH** special function key on the **QUERY** screen. This **SEARCH** screen is displayed. To move the cursor over the **CONSULTING REQUIREMENTS** field, you can press **CONT** twice and then press **ENDLINE** twice. Next, enter the characters **CONCRETE** and press **RELATION** :

Press **C O N C R E T E** **RELATION**

** SEARCH **

LAST CONTACTED_###/##/##

PROJECT###

CLASSIFICATION###-

CONSULTING REQUIREMENTS_###CONCRETE

PROFITABILITY INDEX_###

1. Subtract TOTAL AMOUNT PAST DUE from YTD BUSINESS VOLUME.
2. Divide difference obtained by YTD BUSINESS VOLUME.

PROJECT FROM_###/##/## TO_###/##/##

TOTAL HOURS ALLOTTED_###

1. RELATION 2. RANGE 3. ANY CHR 4. MATCH 5. FORM 6. ABORT 7. ACCEPT

FILE/80 Display

When the special function window changes, press **INCL** . Then press the **ACCEPT** key. After the search is completed, the **NEXT** special function key can be pressed to display each record that has the character sequence **CONCRETE** in the **CONSULTING REQUIREMENTS** field. You can retrieve records for projects with these entries from the **CLIENTS** file:

Project	Consulting Requirements
1202	Design of Reinforced Concrete Beams
0206	Concrete Foundations
0207	Stress Analysis of Flat Concrete Slabs
1701	Structure for Reinforced Concrete Dock
1201	Stress Tests in Reinforced Concrete Struct.
0902	Concrete Fountain
0401	Concrete foundation for greenhouse

Multiple Search Conditions

You can enter information into any of the fields on the `SEARCH` screen to specify search conditions. The more entries you make on the screen, the more specific your search becomes. That is, fewer records are likely to satisfy it. When you enter search conditions into the fields on the `SEARCH` screen and press `ACCEPT`, only records in your file satisfying *all* of the conditions entered are retrieved.

After pressing `SEARCH` on the `QUERY` screen, you can enter multiple search conditions into the blank form displayed on the `SEARCH` screen. For example, records in the `CLIENTS` file can be retrieved when the entry in the `HOURS LOGGED` field is over 10 *and* the entry in the `LAST CONTACTED` field is later than 06/30/82.

To specify the first condition, enter the number 10 in the `HOURS LOGGED` field and press `RELATION`. Then press the `>` special function key. Before entering this number, you must first place the cursor over the `HOURS LOGGED` field. This field is on line 30 of the `CLIENTS` master form. You can press `CONT` once to position the cursor over this field. This is because the `HOURS LOGGED` field on this master form is a tab stop.

To specify the second condition, press `END LINE` to move the cursor to the next field on the `CLIENTS` master form, the `LAST CONTACTED` field. Enter the date 06/30/82 and press `RELATION`. Press the `>` special function key. To start the search, press `ACCEPT`. The following screen shows how your display should look after `ACCEPT` is pressed:

Press `ACCEPT`

```

** SEARCH **

COMPANY_** [REDACTED]
ADDRESS 1_** [REDACTED]
ADDRESS 2_** [REDACTED]
CITY/STATE_** [REDACTED]
ZIP CODE** [REDACTED]

ACCOUNT REP_** [REDACTED]
HOURS LOGGED-> 13 MONTHLY
LAST CONTACTED-> 06/30/82
1 RELATION 2 RANGE 3 PANY CHR 4 [REDACTED] 5 FORM 2 6 ABORT 7 ACCEPT

```

After you press **F10**, FILE/80 searches for a record matching your search conditions. The first record retrieved is for client John Stark. The entry in the HOURS LOGGED field is 35 hours. The entry in the LAST CONTACTED field is 07/14/82.

If you press **F11**, another record is retrieved (if present) that matches your search conditions. For the CLIENTS file, the record for client John Marks is retrieved. The HOURS LOGGED field shows 52. The LAST CONTACTED field displays the date 07/28/82.

These are the records retrieved by entering the previous search conditions and then pressing **F11**:

Last Name	Hours Logged	Last Contacted	Project
Stark	35	07/14/82	0902
Marks	52	07/28/82	0801
Berry	25	07/24/82	1001
Goodman	35	07/29/82	2203

Note: When the QUERY screen is displayed, **CONT** can be pressed to display four 15-line segments of the file record being accessed.

Finding Records With Range

If you're looking for a particular group of records, range searches can be helpful. You enter the lowest and highest "bounds" as entries in a field after pressing **RANGE**. This is different than searches with **RELATION**, where you make the entry in the field before pressing special function keys.

To display the SEARCH screen, press **SEARCH** on the QUERY screen. When the SEARCH screen is displayed, press **ENDLINE** to position the cursor over the field you want to specify low and high bounds for. Next, press **RANGE**.

For example, you might want to look at records that have a balance of \$4,000 to \$10,000 for the YTD BUSINESS VOLUME FIELD. First you need to display the SEARCH screen. Next, tab the cursor to the YTD BUSINESS VOLUME field by pressing **CONT** three times. When the cursor is over this field, press **RANGE**. Then press these keys:

Press **LO BOUND** (4)(0)(0)(0)(0)(0) **HI BOUND** (1)(0)(0)(0)(0)(0) **ACCEPT**

```

** SEARCH **

2. Divide difference obtained by YTD BUSINESS VOLUME.
PROJECT FROM_**MM/DD/YY TO_**MM/DD/YY
TOTAL HOURS ALLOTTED_**
CLIENT SINCE_**MM/DD/YY

TOTAL AMOUNT PAST DUE_**$*****.## YTD BUSINESS VOLUME_CJ$*****.##
AMOUNT PAID THIS MONTH_**$*****.## YTD CONSULTING HOURS_**

RATE SCHEDULE 1_**$*****.## HOURS THIS MONTH 1_**
RATE SCHEDULE 2_**$*****.## HOURS THIS MONTH 2_**

1 UNDO RND 2 LO BOUND 3 _____ 4 _____ 5 FORM 3 6 ABORT 7 ACCEPT

```

FILE/80 Display

Note the **[]** characters in the search/sort indicators of the YTD BUSINESS VOLUME field. These appear after **HI BOUND** is pressed and indicate that a range has been selected for the field. Before **ACCEPT** is pressed, you can press **LO BOUND** or **HI BOUND** to display the bounds entered for the YTD BUSINESS VOLUME field.

After **ACCEPT** is pressed, the search starts. Any records in your file that have a value between \$4,000.00 and \$10,000.00 in the YTD BUSINESS VOLUME field are made available to you. If more than one record matches these conditions, you can press **NEXT** to display the records on the QUERY screen.

Finding Records With ?ANY CHR

The **?ANY CHR** key can be used to locate file records by field entries when you aren't sure of exactly what the spelling is. Also, groups of dates can be conveniently retrieved. You press **?ANY CHR** for any missing character. The field type must be date, autodate, or character. When you press **?ANY CHR**, a question mark is entered into whatever field the cursor is on. These question marks are interpreted on a character-by-character basis when records are retrieved. You can use this key with **INCL** or **=** for relation searches.

?ANY CHR makes it easy to selectively retrieve records by month, day, or year. This feature is a real convenience when you want to review, for instance, the records of each project started during a **specific month**. To review the projects started in June, press **SEARCH** and position the cursor over the PROJECT FROM field. This field has a MM/DD/YY format. You can press **CONT** two times and then press **END LINE** four times to position the cursor over this field. Next, press these keys:

Press (0) (6) ?ANY CHR ?ANY CHR (8) (2) ACCEPT

** SEARCH **

LAST CONTACTED_###/##/##

PROJECT###

CLASSIFICATION###-

CONSULTING REQUIREMENTS_###

PROFITABILITY INDEX_###

1. Subtract TOTAL AMOUNT PAST DUE from YTD BUSINESS VOLUME.

2. Divide difference obtained by YTD BUSINESS VOLUME.

PROJECT FROM_###/##/## TO_###/##/##

TOTAL HOURS ALLOTTED_###

1 RELATION 2 RANGE 3 ?ANY CHR 4 5 FORM 2 6 ABORT 7 ACCEPT

FILE/80 Display

File records with 06 and 82 in the month and year positions, respectively, of the PROJECT FROM field are retrieved. When **ACCEPT** is pressed, the first record matching these conditions (in primary key order) is displayed in the information window of the QUERY screen. You can examine this record by pressing **CONT** or holding down **SHIFT** and pressing **ROLL**. Press **NEXT** to see if any other projects were started in June of 1982. Records for the following projects can be displayed:

Project	Project From
0206	06/01/82
0207	06/01/82
1204	06/06/82

If no projects had been started in June, an appropriate message appears in the title/feedback window. Should this be the case, the form you entered the search conditions on is displayed with the SEARCH screen. You can then enter conditions for a second search.

To review the **previous month**, modify the month to 05 and press **ACCEPT**. FILE/80 initiates a search for any projects started in May. Or, you can press **ABORT** to display the QUERY screen with the **ADD**, **SEARCH**, and **DONE** special function keys. Press **DONE** if you're finished using the QUERY screen. The FILE/80 screen is displayed. You can press **DONE** a second time to access another file or press **EXIT** to return your computer to calculator mode.

Finding Records With *MATCH

You can enter search conditions with ***MATCH** when the ending letters, digits, or other characters in a field of a record you wish to display are unknown. The ***MATCH** special function key is only displayed when the cursor is on character fields (formatted or unformatted).

First you enter the starting characters in a field on the **SEARCH** screen. To do this, just move the cursor to the field you want to locate the record with. Next, enter the particular combination of characters the record you want to locate starts with. Then press ***MATCH**. **FILE/80** places an asterisk in the field. Any other search conditions can now be specified on the form. Finally, press **ACCEPT**. A message in the title/feedback window indicates that a search is in progress. If a record is found matching your search conditions, it is displayed on the **QUERY** screen.

Locating records with ***MATCH** is easy. The keys you need to press to locate the records of companies with zip codes that start with 91 are shown on this **SEARCH** screen. To display this screen you press **SEARCH**. To move the cursor over the **ZIP CODE** field, you can press **CONT** and then press **SHIFT** **ENDLINE** two times. This screen shows what your HP-86/87 display should look like after ***MATCH** is pressed.

Press **9 1 *MATCH ACCEPT**

** SEARCH **

COMPANY_# [REDACTED]

ADDRESS 1_# [REDACTED]

ADDRESS 2_# [REDACTED]

CITY/STATE_# [REDACTED]

ZIP CODE# [REDACTED] 91*

ACCOUNT REP_# [REDACTED]

HOURS LOGGED_# [REDACTED] MONTHLY

LAST CONTACTED_# [REDACTED] / [REDACTED] / [REDACTED]

1 RELATION 2 RANGE 3 COMPANY CHR 4 *MATCH 5 FORM 3 6 REPORT 7 ACCEPT

For each of the records retrieved, the entry in the ZIP CODE field starts with 91:

Company	City/State	Zip Code
Irrigation Consultants, Inc.	San Fernando, California	91343
Solar Planners Unlimited	Van Nuys, California	91403
Marks Swimming Pool Supplies	North Hollywood, California	91601
Stark Medical Associates, P.C.	Los Angeles, California	91607

Note: Several companies in the CLIENTS file have more than one project with CHANEY, MANN, and HILL. Therefore, you can retrieve several records with the same entries in the COMPANYY, CITY/STATE, and ZIP CODE fields when pressing **NEXT** or **PREVIOUS**.

Alternate Search Conditions

Pressing **FORM 2** lets you specify an alternate set of search conditions for locating a record. This means you can use two different forms on the SEARCH screen to enter the conditions of a search. Records satisfying **either or both** of the conditions are retrieved. A total of 10 search conditions can be specified.

First, specify one set of conditions on the form displayed in your information window. You can include any of the options described in this section. Then, press **FORM 2**. A blank form is displayed and the **FORM 2** special function key changes to **FORM 1**. You can enter a second set of search conditions on this blank form.

When you press **ACCEPT**, FILE/80 searches for records that satisfy the conditions on one form or the other. You could have obtained the same records with two separate searches. However, when **FORM 2** is used you can look at the records satisfying either condition together, by pressing **NEXT** or **PREVIOUS**. It is also possible to specify two different search conditions for a single field.

You have the option of displaying the first form you entered conditions on by pressing **FORM 1**. When you press **FORM 1**, FILE/80 displays the original form. The special function key **FORM 2** reappears where **FORM 1** used to be. You can make any changes to the first form, or display the second form by pressing **FORM 2** again.

When both forms have the proper search conditions, press **ACCEPT**. You can press **ACCEPT** when either the first or second form is displayed—it makes no difference in the search. You can use the **RELATION**, **RANGE**, **ANY CHR**, or **XMATCH** special function keys with **FORM 2** / **FORM 1**. Or, you can simply enter information into fields on both forms to retrieve records *equal* to entries made on either or both of the two forms.

Here's an example of combining two searches in one by pressing **FORM 2** with the CLIENTS file. Records with over 40 in the HOURS LOGGED field *or* records with a date later than 07/25/82 in the LAST CONTACTED field are retrieved. After the search, you can press **NEXT** and **PREVIOUS** to

display all the records that satisfy these conditions in the CLIENTS file. The following steps enable you to retrieve these records from the FILE/80 Demonstration Disc.

- a. Press **SEARCH** to clear any previous search conditions.
- b. Move the cursor over the HOURS LOGGED field by pressing **CONT**.
- c. Enter the number 40 in the HOURS LOGGED field and press **RELATION**.
- d. Press **▷**.
- e. Press **FORM 2**. This special function key should now be **FORM 1**.
- f. Press **END LINE** to move the cursor over the LAST CONTACTED field.
- g. Enter the date 07/25/82 into the LAST CONTACTED field.
- h. Press **RELATION**.
- i. Press **▷**.
- j. Press **ACCEPT**.

The following records satisfy either or both of the conditions just entered.

Last Name	Hours Logged	Last Contacted	Project
Marr	4	07/30/82	1101
Marks	52	07/28/82	0801
Robinson	42	06/12/82	1203
Goodman	35	07/29/82	2203
Brady	2	08/01/82	0403
Johns	9	07/29/82	0306

Updating File Records

The **UPDATE** special function key is on the QUERY screen. When you want to modify a record already in your file—to change the information in some of its fields, you first locate the record with a search. When the record is displayed on the QUERY screen, press **UPDATE** if you wish to modify it. Position the cursor over any field you wish to edit.

The usual keys can be used to change the information in each field. For character fields or date fields you can use **SPACE BAR**, **BACK SPACE**, **←**, or **→**. To edit numeric fields only **BACK SPACE** can be used.

In unformatted character fields, any entries are valid. But for numeric positions in formatted character or date type fields, only the digits 0 through 9 and the blank character are allowed. Numeric fields can only contain numbers that are valid for the specific field type.

Note: You cannot modify autodate type fields. The date you enter at the beginning of a session is placed into these fields automatically on records displayed in the information window of the UPDATE screen.

The following special function keys are provided on the UPDATE screen:

RESTORE Press this key to display the record the way it was before any changes were made.

CALC Press this key to add, subtract, multiply, or divide numbers. This key only appears when the cursor is on numeric fields. Refer to **Instructions for Using CALC** on page 63 for more information.

SHOW DUP Press this key to display another record already stored in your file with the same primary key as the record you just updated. Unless your file has a unique primary key and you have "duplicated" the primary key of another record, this key is not displayed.

ORIGINAL Press this key to view the record you just updated after displaying a record already in your file with the same primary key. This key is only present after pressing **SHOW DUP**.

ABORT Press this key to display the QUERY screen and leave the record on the UPDATE screen unchanged.

ACCEPT Press this key to enter all changes made to the record being accessed onto the disc where the record is stored.

To change records in your file, you must first access the records with a search. Any records to be changed must be displayed on your HP-86/87 screen. FILE/80 Program Disc #1 and all discs containing the files you wish to update must be in disc drives connected to your HP-86/87. Load the FILE/80 program as usual. Check to see that a FILE/80 Program Disc is in the default drive and press **(RUN)**. Follow the procedures at the beginning of this section for accessing a file already stored on disc with **OLD FILE**.

If you retrieve a group of records, the **NEXT** and **PREVIOUS** keys can be used to display each record satisfying the search conditions. You can examine a group of records this way and then decide which ones you want to change. *Whenever* a record is displayed on the QUERY screen, you can update it by pressing **UPDATE**.

To update the record for project number 1202 in the CLIENTS file, press **QUERY** on the FILE/80 screen. Then press **SEARCH** on the QUERY screen. When the SEARCH screen is displayed, do the following:

- a. Position the cursor over the PROJECT field. To do this, you can press **(CONT)** twice.
- b. Enter the digits 1202 into the PROJECT field by pressing **(1)(2)(0)(2)**.
- c. Press **ACCEPT**.
- d. The record for project number 1202 in the CLIENTS file is displayed on the QUERY screen.
- e. Press **UPDATE** to make changes to this record.

Press **UPDATE**

** QUERY **

Please select a special function key.

LAST CONTACTED_**08/22/82

PROJECT#**1202

CLASSIFICATION**01-03

CONSULTING REQUIREMENTS_**Design of Reinforced Concrete Beams

PROFITABILITY INDEX_**1

1. Subtract TOTAL AMOUNT PAST DUE from YTD BUSINESS VOLUME.
2. Divide difference obtained by YTD BUSINESS VOLUME.

PROJECT FROM_**03/15/82 TO_**00/00/00

TOTAL HOURS ALLOTTED_**820

1. ADD 2. SEARCH 3. NEXT 4. _____ 5. UPDATE 6. DELETE 7. DONE

FILE/80 Display

- f. This UPDATE screen is displayed. Notice the date entered at the beginning of the session is automatically entered into any autodate type fields. In this case, the date 08/12/82 has been automatically entered into the LAST MODIFIED ON field.

** UPDATE **

ACCOUNT#**03-1250

CHANNEY, MANN, AND HILL
Consulting Engineers

PHONE_**(<017> 555-8512

CLIENT QUICK REFERENCE FILE

LAST MODIFIED ON_**08/12/82

LAST NAME_**Robinson

FIRST NAME_**Cliff

MIDDLE INITIAL_**H

COMPANY_**Robinson-Douglas, Inc.

1. RESTORE 2. _____ 3. _____ 4. _____ 5. _____ 6. RESET 7. ACCEPT

FILE/80 Display

- g. Position the cursor over the field you wish to update and make changes as desired. The following screen shows the PHONE field has been updated:

```

** UPDATE **

ACCOUNT_**08-1280          PHONE_**(<517>) 888-8158
CHANEY, MANN, AND HILL
  Consulting Engineers
CLIENT QUICK REFERENCE FILE

LAST MODIFIED ON_**08/13/88
LAST NAME_**Robinson
FIRST NAME_**C. J.
MIDDLE INITIAL_**H
COMPANY_**Robinson-Opales Inc.
1 RESTORE 2 _____ 3 _____ 4 _____ 5 _____ 6 ACCEPT 7 ACCEPT

```

FILE/80 Display

- h. When all the desired changes have been made to the record that was accessed, press **ACCEPT** on the UPDATE screen.
- i. FILE/80 displays the QUERY screen. The record you just updated is in the information window. You can look over the record by pressing **(CONT)** or holding down **(SHIFT)** and pressing **(ROLL)**.
- j. You can press **NEXT** or **PREVIOUS** to display other records retrieved by the search or press **SEARCH** to initiate another search.
- k. When you are done using the QUERY screen, press **DONE**. The FILE/80 screen is displayed.
- l. You can press **EXIT** to return your HP-86/87 to calculator mode or press **DONE** if you want to access another file.

Unique Primary Key Entries

When updating a record in your file, it is possible to change the entries in its primary key fields so they match another record already stored in your file. This is only allowed in files with a non-unique primary key.

In a file with a primary key designated as unique, the following occurs if you should duplicate the primary key of another record:

- A message is displayed in the title/feedback window of the UPDATE screen when you press **ACCEPT**.
- The **SHOW DUP** special function key is displayed.

Press **SHOW DUP** to view the record in your file with the same entries in the primary key fields. This record, however, cannot be modified since it is not accessed with the SEARCH screen. The **ORIGINAL** special function key alternates with the **SHOW DUP** key depending on which record is displayed. After noting the duplicate record, you can press **ORIGINAL** to display the record you attempted to update.

If the primary key is designated as unique, the record on your screen cannot be placed in the file until its primary key is unique. You have the following options:

- You can change the primary key fields of the record so that it doesn't match any other records in your file. Once the primary key fields are unique, pressing **ACCEPT** will update your file with the entries currently on the file record.
- You can press **ABORT** to leave the file record unchanged.

Deleting File Records

Once you have located a record in your file with the SEARCH screen, it is displayed in the information window of the QUERY screen. To delete the record, you press **DELETE**. After this, FILE/80 displays the DELETE screen. Two special function keys are provided on the DELETE screen:

ABORT Press this key if you decide the record should not be deleted after pressing **DELETE**. When you press **ABORT**, the QUERY screen is displayed. No record is deleted from your file.

ACCEPT Press this key to delete or remove the record displayed from your file. However, after you press **ACCEPT** FILE/80 gives you another chance to save the record with the **UNDO** special function key.

Use of UNDO

Before a record is deleted, it must be displayed in the information window of the DELETE screen. This gives you an extra level of protection from accidentally deleting a record. After you press **ACCEPT** on the DELETE screen, the QUERY screen is displayed. However, the special function key usually labeled **DELETE** changes to **UNDO**.

If you press **UNDO**, the record you just “deleted” is put back into your file. If **ADD**, **SEARCH**, or **DONE** are pressed, the record you deleted cannot be retrieved. Also, this record cannot be retrieved if you press **NEXT** or **PREVIOUS** and a different record is displayed.

To delete a file record, follow these instructions:

- a. Access your file by pressing **OLD FILE** and supplying the file name. After entering the current date, verify the MSUSs and press **ACCEPT**.
- b. Press **QUERY** on the FILE/80 screen.
- c. Press **SEARCH** on the QUERY screen.
- d. Perform a search by entering information in one or more of the fields on the blank form of the SEARCH screen and pressing **ACCEPT**. You can use any of the special function keys of the SEARCH screen to help you locate the record in your file. If necessary, press **NEXT** or **PREVIOUS** to display the record you want to delete on the QUERY screen.
- e. When the record you want to delete is displayed on the QUERY screen, press **DELETE**.
- f. When FILE/80 displays the DELETE screen, press **ACCEPT**.
- g. FILE/80 displays the following QUERY screen. You can press **UNDO** to retrieve the deleted record.

```

** QUERY **

```

```

Please select a special function key.

```

```

1 ADD 2 SEARCH 3 NEXT 4 _____ 5 _____ 6 UNDO 7 DONE

```

FILE/80 Display

- h. Press **DONE** when you are finished accessing records in your file.
- i. The **FILE/80** screen is displayed.
- j. If you are finished using your files, press **EXIT**.

SEARCH Screen Summary

The special function keys listed in this summary appear on the **SEARCH** screen. This screen can be accessed by either pressing **SEARCH** on the **QUERY** screen or by pressing **SEARCH** on the **PRINT SPECIFICATIONS** screen. If you press **SEARCH** on the **QUERY** screen, any records satisfying the search will be made available to you with the **NEXT** and **PREVIOUS** special function keys.

When you press **SEARCH** on the **PRINT SPECIFICATIONS** screen, **FILE/80** displays the **SEARCH** screen. The **PRINT SPECIFICATIONS** screen is displayed when you press **ACCEPT**. Individual records that satisfy the search are not available to you. They are accessed by **FILE/80** when reports, letters, or labels are produced.

In each case, entries are made on a blank master form in the information window of the **SEARCH** screen. Each entry is a search condition. You can specify up to a total of 10 search conditions on the **SEARCH** screen. When you have specified what records are to be accessed, you press the **ACCEPT** special function key.

RELATION Press this key to specify records with the indicated relation to information entered in any field on the master form. The cursor must be over the field when **RELATION** is pressed. The special function keys listed below are displayed. Records satisfying the conditions you enter are accessed. You can specify these conditions for any fields on the master form.

= Press this key to access all records with an entry equal to what is entered in the field the cursor is over.

<> Press this key to access any records that don't have the entry in the field the cursor is over.

> Press this key to access any records with entries greater than what is entered in the field the cursor is over.

>= Press this key to access all records with entries greater than or equal to what is entered in the field the cursor is over.

< Press this key to access any records with entries less than what is entered in the field the cursor is over.

<= Press this key to access all records with entries less than or equal to the entry in the field the cursor is over.

FNCL Press this key to access all records that contain the sequence of characters in the field the cursor is over.

RNGE You can choose upper and lower bounds for specific fields by pressing this special function key. First you move the cursor to the field you want to use. Only records falling within the upper and lower bounds you specify for this field are accessed. When the cursor is over the field you wish to enter bounds for, press **RNGE**. Prompts for entering lower and upper bounds are displayed in the title/feedback window.

UNDO RNG Pressing this special function key clears the range for the field the cursor is over. The original **SEARCH** special function keys are displayed.

LO BOUND Press this special function key to enter the lower bound of a range. If the higher bound has been entered, you can press **LO BOUND** to display the lower bound. Once the range has been entered, this special function key only appears if the upper bound is on the screen.

HI BOUND Press this special function key to enter the upper bound of a range. If the lower bound is currently displayed, you can press **HI BOUND** to display the upper bound.

ANY CHR Press this special function key to specify a single character position for any letter, special character, or digit. For each of these positions, **FILE/80** enters a question mark in the field. Records are accessed regardless of what character appears in these positions of the field.

***MATCH** When you want to access all records starting with a certain sequence of characters, you can use this special function key. First enter the characters and then press ***MATCH**. An asterisk is placed after the last character you enter.

FORM 2 Pressing this special function key gives you a second master form to enter conditions on for accessing records. When pressed, the **FORM 2** special function key label changes to **FORM 1**. Records satisfying conditions on either form are accessed.

FORM 1 This special function key is displayed after **FORM 2** is pressed. It takes the place of **FORM 2** while the second form is displayed. Press **FORM 1** to display the original form.

QUERY Press this special function key to display the **QUERY** screen. Any conditions you entered to select records with are cleared.

ACCEPT Press this special function key when you are finished entering search conditions. The conditions entered on the master form determine which records are accessed. When no conditions are specified, every record in your file is accessed.

You can reduce the number of records accessed by entering multiple conditions on the master form. If you specify an alternate set of conditions on the second form by pressing **FORM 2**, the number of records accessed can increase. When the alternate form is used, records satisfying conditions on the first form, the second form, or both forms are accessed.

SEARCH Summary Table

Search Screen		Field Types					
Condition	Indicator	Char	Integer	Currency	Float	Date	Autodate
RELATION	<, >, <>, <=, >=, =	X	X	X	X	X	X
INCL	I	X					
RANGE	[]	X	X	X	X	X	X
?ANY CHR	?	X				X	X
*MATCH	*	X					

An X indicates a search can be specified.

Search Efficiency

The time required to locate specific records in your file depends upon which fields search conditions are entered in. When one of the fields search conditions are entered in is a secondary key or the first field designated for the primary key, the search is very efficient. Searches on key fields are much faster than searches on non-key fields.

However, searches using **INCL** or **?ANY CHR** conditions in the first character positions of fields are considerably slower than searches specified with other special function keys even if key fields are involved. When **FORM 2** is used, searches can take longer when conditions are entered in different fields than those on the original form.

Notes



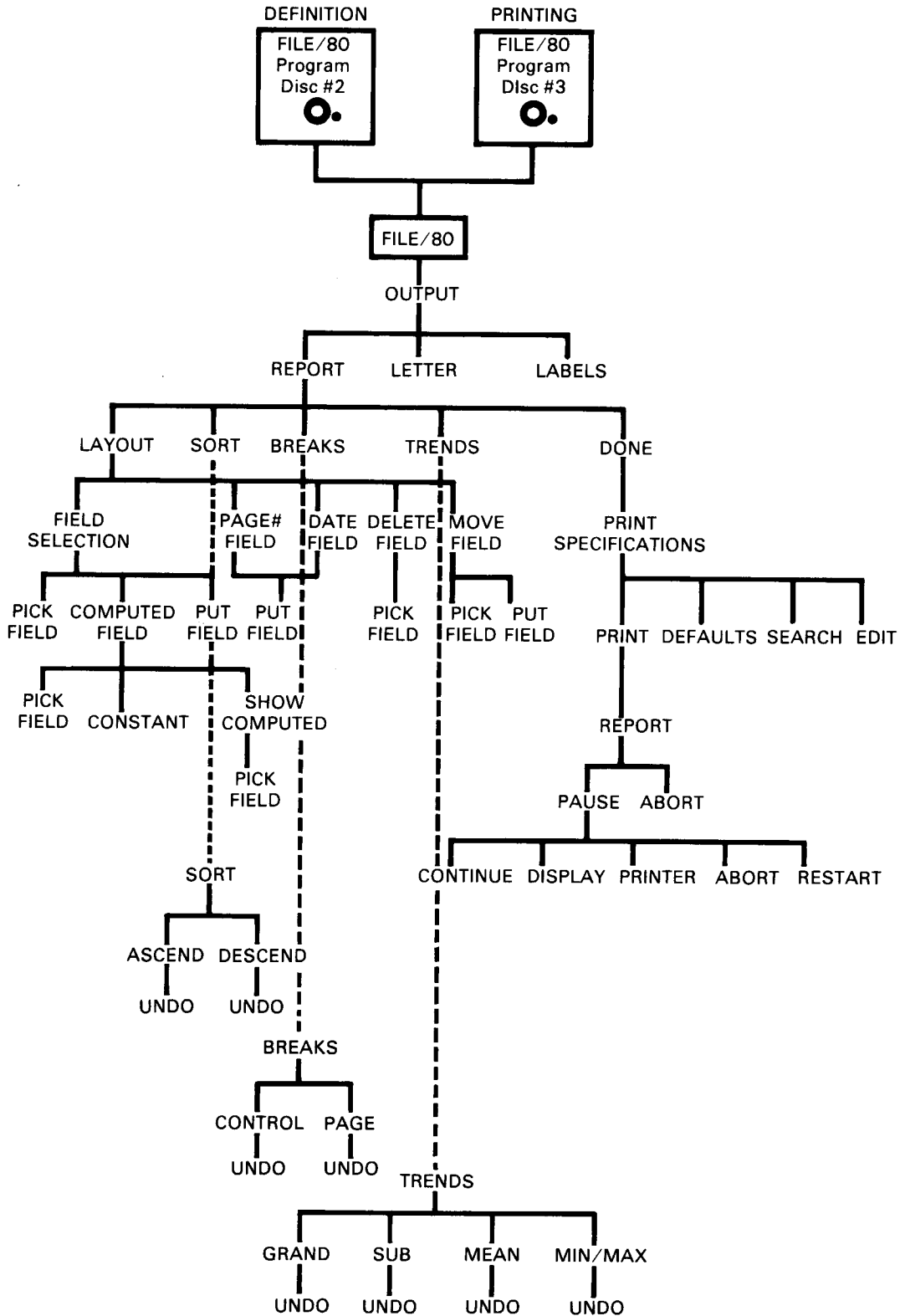

REPORT Diagram

Generating Reports

In this section you learn how to produce printed reports comprised of the information currently stored in your files. You will learn how to design reports and how to specify totals and other statistics for them. Besides this, you can use the SEARCH screen to select which records are included in reports, and you can choose the printing order of these records. Once defined and stored, a report can be generated at any time. The following are required for the examples in this section:

- FILE/80 Program Disc #2
- FILE/80 Program Disc #3
- FILE/80 Demonstration Disc

The disc(s) containing the file for which a report is specified must be on-line when the report is defined, edited, or printed.

Use of FILE/80 Program Discs

It is not necessary to have both FILE/80 Program Discs in drives simultaneously. Use FILE/80 Program Disc #2 if you are defining a report or editing one already stored on disc. Use FILE/80 Program Disc #3 if you are printing copies of file records or reports already stored on disc. Any FILE/80 Program Disc can be inserted when the LOAD "FILE/80" command is issued. If FILE/80 cannot perform the operations you request, it will tell you which Program Disc to insert.

Introduction

Creating a report is similar to creating a master form in many respects. The layout of text and fields on a report is defined in much the same way. And as on the master form, you always have the option of changing any attributes of a printed report. Instead of being called master forms, the specifications for printed output are called *output formats*. Any number of output formats can be defined for each file you create.

In sections 5 and 6 of this manual you'll learn how to produce letters and labels for individual records in your file. These types of output are specified by formats also. Format types are designated by pressing the special function keys **REPORT**, **LETTERS**, or **LABELS** on the OUTPUT TYPE screen after entering the name of the format. Each format has its own set of specifications.

In addition to instructing FILE/80 on how your printed reports should look, report output formats also contain information about when totals should be printed and the order in which the records should

appear. The capability to define these conditions is a major advantage of choosing a computerized filing system like FILE/80. As the information in individual records changes, your reports reflect this new information and no modifications need to be made to the output format itself.

With a single report, the relevant fields from each record can be presented along with subtotals for groups of records and averages for other selected fields. Reports can provide you with a condensed document that reveals pertinent information about your file records.

In this section you'll find out how to sort records, find averages, print minimum/maximum values, and specify grand totals for selected groups of records in your file. You can also specify when subtotals are to be printed—this can include starting a new report page. You'll learn about the ease of making copies of each file record with the **DUMP ALL** special function key. Pressing **DUMP ALL** causes FILE/80 to print a copy of each record in your file with a master form summary.

Report Definition

The first step in defining a report is to display the **OUTPUT** screen. As usual, you load the FILE/80 program and press **OLD FTTT**. Use FILE/80 Program Disc #2. If you intend to print copies of your file records first, use FILE/80 Program Disc #3 instead and make sure your printer is turned on. Press **OLD FTTT**, enter the file name, and verify the MSUSs of the disc drives connected to your HP-86/87. Press **OUTPUT** when the FILE/80 screen is displayed.

Press **OUTPUT**

```

FILE NAME: CLIENTS          ** FILE/80 **          TODAY'S DATE: 05 12 88
Please select a special function key.
:
:
1. QUERY  2. OUTPUT  3. REDEFINE  4. TABS  5. DEFAULTS  6. EXIT  7. DONE
  
```

FILE/80 Display

When the FILE/80 screen is displayed, you can press **EXIT** to return to calculator mode or press **DONE** to display the screen with the **OLD FTTT** and **NEW FTTT** special function keys. If you press **OUTPUT**, the next screen is displayed.

Note: Do not enter a format name if you wish to obtain copies of your file records or a master form summary with the **DUMP ALL** key. Refer to **Use of DUMP ALL**, page 94, for instructions.

Accessing Output Formats

A format name is needed to identify your reports, letters, or labels on disc. Output format names can contain any upper or lower case letter or digit and have a maximum length of eight characters. Whenever you enter the name of a report output format, FILE/80 checks if a disc file beginning with that name and ending with the characters `_S` is on-line. If the disc file is present, then the `PRINT SPECIFICATIONS` screen is displayed. Instructions for using this screen are provided under **Printing Reports** on page 115. When you enter the name of an output format not on-line, FILE/80 displays the `OUTPUT TYPE` screen for defining a new format.

The name `PROJECT` differentiates this output format from the output formats already stored on the FILE/80 Demonstration Disc. To enter an output format named `PROJECT`, do the following:

Press `P R O J E C T` `ENDLINE`

```

                                     ** OUTPUT **
FORMAT NAME? PROJECT
:
:
1 DUMP ALL 2 _____ 3 _____ 4 _____ 5 _____ 6 ABORT 7 _____

```

Use of DUMP ALL

You can print and/or display records for the file being accessed with the **DUMP ALL** key. A master form summary (see page 56) is printed first. When you press **DUMP ALL** on the **OUTPUT** screen, the **PRINT SPECIFICATIONS** screen is displayed. To start the process of printing your master form summary and file records, you press **PRINT**. The master form summary includes the following information:

- File name.
- Number of records currently stored in the file.
- Maximum number of records that can be stored in the file.
- Primary keys.
- Secondary keys.
- Name, type, length/appearance, and location (line, column) for all fields.

If you only want the master form summary, then press **ABORT** after it is printed. Otherwise, the file records are printed after the master form summary. Both are displayed on the **DUMP ALL** screen as they are printed.

When printing is completed, the special function window on the **DUMP ALL** screen changes. You can press **OUTPUT** to display the **OUTPUT** screen. Instructions for using the **PRINT SPECIFICATIONS** and the **REPORT** screens are provided later in this section under **Printing Reports**.

To begin the definition of the **PROJECT** report output format, press **REPORT**. Notice the new format name is displayed in the title/feedback window of this screen.

Press **REPORT**

```

** OUTPUT TYPE **
Please select a special function key.
1 REPORT 2 LETTER 3 LABELS 4 _____ 5 _____ 6 REPORT 7 _____

```

ABORT Press this key to display the screen with the `FORMAT NAME` prompt. This allows you to re-enter the format name when misspelled or when the file is not on-line.

This screen is displayed when you press **REPORT** on the `OUTPUT TYPE` screen:

```

** REPORT FORMAT **                               Format: PROJECT
Please select a special function key.
:
:
1 LAYOUT  2 SORT  3 BREAKS  4 TRENDS  5 REPORT  6 ABORT  7 DONE

```

FILE/80 Display

The `REPORT FORMAT` special function window is used to define many aspects of your report:

LAYOUT Press this key to display the `REPORT LAYOUT` screen. You can pick fields from the master form, enter text, and decide on the headings and footings for your report.

SORT Press this key to designate up to five fields on the master form as sort fields (optional). These fields are used to determine the printing order of records in your report. If no fields are selected, your report is printed in primary key order.

BREAKS Press this key to designate when the next report page or subtotals are to be printed. When you press **BREAKS**, the `BREAK FIELDS` screen is displayed. On your report, subtotals and/or the next page can be printed whenever information changes in break fields. These are chosen on the `BREAK FIELDS` screen. Refer to **Sort Fields, Breaks, and Subtotals**, page 112, for an explanation.

Note: The **BREAKS** special function key is not present until at least one sort field has been designated on the master form.

TRENDS Press this key to specify totals and other trends for summarizing numeric fields on your report. Up to 15 grand totals, five subtotals, five averages, and five minimum/maximum trends can be used.

Note: The **TRENDS** special function key is only present after at least one field has been placed on your report with the `REPORT LAYOUT` screen.

ABORT Press this key to display the `OUTPUT` screen and clear the current output format.

DONE Press this special function key after defining your report to store the output format on disc. After it is stored, `FILE/80` displays the `PRINT SPECIFICATIONS` screen so your report can be printed.

Note: The **DONE** special function key is only present when at least one field has been placed on your report.

To define a report, you first specify its layout by pressing **LAYOUT** on the `REPORT FORMAT` screen. Next, printing order can be selected with the **GORI** special function key. To designate when the next report page or subtotals are to be printed you can press **BRIKKT**. After this, you can press **TRINDT** to specify totals, averages, and minimum/maximum values for your report. Finally, you press **DONE** to store your output format on disc.

Report Width

When you define your report, up to 132 columns can be used. The **←** and **→** keys can be used to scroll the report horizontally on your display. The range of columns currently displayed on your screen is indicated in the title/feedback window. If any text or fields are entered past column 80, then your report is printed in compressed mode with 132 columns.

Designing Reports

You can pick any combination of 18 lines for the headings, body, or footings on a report. For example, if you used six lines for the report body, the heading could be nine lines long and the footing could be one to three lines long.

With the `REPORT BODY` screen, you select the body of the report—the portion that is printed with each record. The lines above the body of your report are treated as headings and the lines below the body become the footings. The headings, body, and footings for the `PROJECT SUMMARY REPORT` are shown in the **Sample REPORT Diagram**, on page 113. The use of the `REPORT BODY` screen is explained under **Headings, Body, and Footings** on page 104.

Report Layout

The screens and keystrokes that follow show you how to enter the layout of the PROJECT SUMMARY REPORT, shown in the overview. The fields on this report are selected from the CLIENTS master form that is stored on the FILE/80 Demonstration Disc. Two types of information for your report are specified with the REPORT LAYOUT screen, fields and text. To specify the layout of a report, press **[LAYOUT]** on the REPORT FORMAT screen. The REPORT LAYOUT screen is then displayed.

```

Columns  0-99          ** REPORT LAYOUT **          Format:  PROJECT
                                     Line  0   Column  0
Please select a special function key or enter text.
█

1. FIELD  2. PAGE #  3. DATE  4. DELETE  5. MOVE  6. ABORT  7. ACCEPT

```

FILE/80 Display

The following special function keys are provided:

[FIELD] Press this key to display the master form on the FIELD SELECTION screen. You can pick fields off the master form and place them on your report. Field names are placed directly above fields as *text* on your report when **[PUT]** is pressed.

[PAGE #] Press this key to place a page number field on your report. FILE/80 will automatically number the pages of your report starting with number one. The page number field is three digits wide and can be placed anywhere. When you press **[PAGE #]**, the page number field appears instantly on your display. You position it with the cursor keys and press **[PUT]**.

[DATE] Press this key to place a date field on your report. This field is eight characters long and has the same format as specified in section 2. On a report, the date field shows the current date on each page.

[DELETE FIELD] Press this key to display the DELETE FIELD screen for removing fields already placed on your report. Simply position the cursor over the field you want to remove and press **[PICK]**.

Note: **[DATE]** only appears when at least one field is on your report.

MOVE Press this key to move fields already placed on your report. When pressed, the MOVE FIELD screen is displayed. You position the cursor over the field you want to move and press **PICK**. Move the field to the proper position and then press **PUT**. (If you had pressed **PICK** accidentally, simply press **PUT** without moving the field.)

Note: Any trends selected for the field moved must be re-entered. Also, **MOVE** only appears when at least one field is on your report.

ABORT Press this key to erase your report.

ACCEPT This special function key can be pressed after the layout of your report has been specified. The REPORT BODY screen is displayed to select the body of your report.

Report Fields

The fields on a report are selected from the master form. The information window of the REPORT LAYOUT screen alternates from the master form to the output format as you choose fields from the master form and put them on your report. To place a field on your report, you first press **TTTT** on the REPORT LAYOUT screen.

Note: A maximum of 100 fields can be placed on a report.

Picking Fields

The FIELD SELECTION screen is displayed when **TTTT** is pressed on the REPORT LAYOUT screen. If you intend to use a field name as a column heading on a report, it should be less than or equal to the length of the field. As a column heading, the field name appears directly over the field.

The Auto heading is ON/OFF setting determines if the field name will also be placed on the report. This setting is changed with the **HEADING** key. The default setting is NO, but if the setting is changed to YES, it will remain on for the current session.

When the field name contains fewer characters than the length of the field, it is centered. When the field name is longer, rightmost characters in the field name are removed. The field name is aligned with the left side of the field.

Before picking a field, verify that the heading indicator is properly set. To change the indicator, press **HEADING**. To pick a field for your report, move the cursor over the field you want on the master form and press **PICK**. To pick the CLASSIFICATION field on the CLIENTS master form, press **ENDLINE** to move the cursor over the field and do the following.

Press **HEADING** **PICK**

```
Form lines 01-03      ** FIELD SELECTION **      Format: PROJECT
Auto heading is ON
```

LAST CONTACTED_**/ **/ **

PROJECT**NNNN

CLASSIFICATION**NN-00

CONSULTING REQUIREMENTS_**

PROFITABILITY INDEX_**

1. Subtract TOTAL AMOUNT PAST DUE from YTD BUSINESS VOLUME.
 2. Divide difference obtained by YTD BUSINESS VOLUME.

PROJECT FROM_**/ **/ ** TO_**/ **/ **

TOTAL HOURS ALLOTTED_**

1 **PICK** 2 **COMPUTED** 3 **HEADING** 4 **_____** 5 **_____** 6 **ABORT** 7 **_____**

FILE/80 Display

You can use the following special function keys:

PICK Press this special function key to include the field the cursor is over in your report. After pressing **PICK**, you can position both the field and field name on your report with the **PUT FIELD** screen.

COMPUTED Press this special function key if you want to do arithmetic on numeric fields for each record in your report. Any numeric field on your master form can be used. Besides numbers you enter, the results from other computed fields can also be included. The operators (+), (-), (*), (/), and (=) are used. Press (=) to end the expression. Refer to **Computed Fields** on page 101 for instructions.

HEADING Press this key to change the Auto heading is ON/OFF indicator in the title/feedback window.

ABORT Press this key to display the **REPORT LAYOUT** screen and leave your report as is. The auto heading setting is not changed.

Putting Fields

After choosing a field on the **FIELD SELECTION** screen or specifying a computed field, the **PUT FIELD** screen is displayed. The report you are defining is displayed in the information window. Use the cursor keys to position the field on your report and then press **PUT**.

For example, to place the `CLASSIFICATION` field so that the first character of the field name is in line 9, column 6, press the cursor keys until that location is indicated in the title/feedback window. Then press `PUT`. When `PUT` is pressed, the field name becomes text on the report. If desired, it can be removed with the `SPACE BAR` or `BACK SPACE` keys.

Note: The line and column counters display the location of the upper leftmost character position of the inverse video box.

Press `PUT`

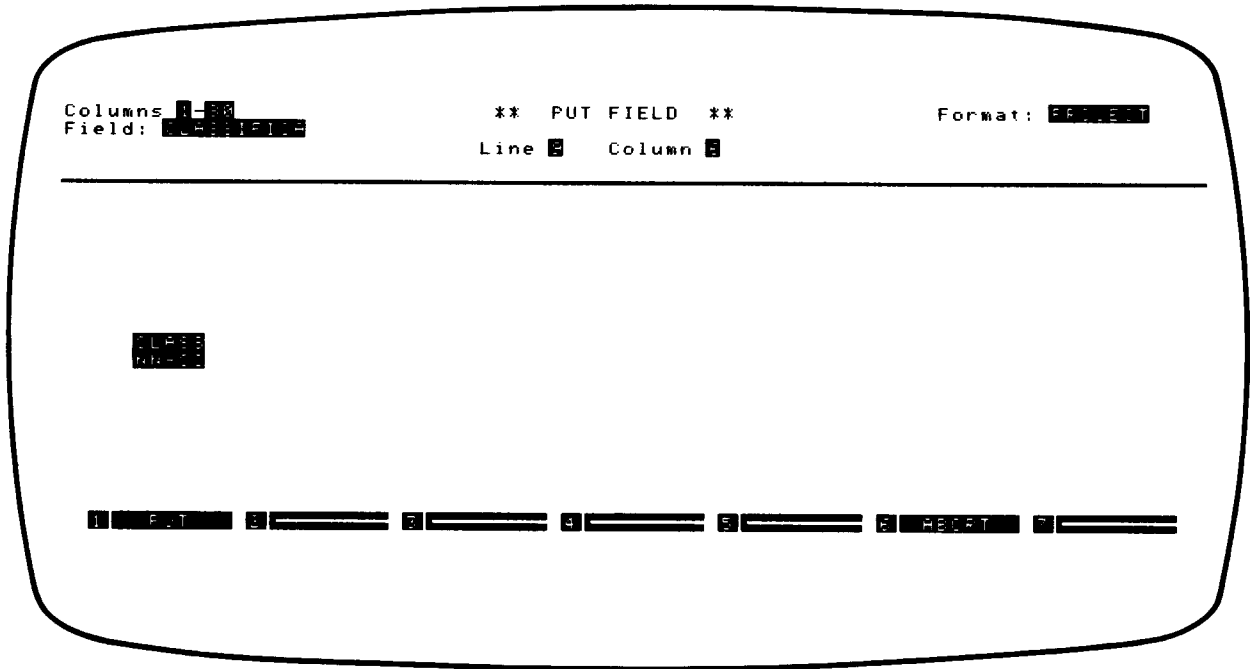

FILE/80 Display

The following special function keys are provided:

PUT Press this special function key when the field is in the correct location on the output format. The cursor keys can be used to position the field. The inverse video box around the field name disappears when `PUT` is pressed—it turns into text.

ABORT Press this special function key to display the `REPORT LAYOUT` screen. You must press `PUT` again to add a field to your report.

It is suggested you allow at least three spaces to the left of each numeric field you anticipate taking grand totals or subtotals for. Refer to **Report Trends** on page 112 for more information.

Computed Fields

FILE/80 lets you include fields on a report that are the result of an expression you enter. Constants you enter, as well as fields on the master form, can be used in the calculations. Depending on the fields used, a currency or float type field of length 12 is used for printing the result.

The expression you enter is evaluated according to the *arithmetic hierarchy*, as defined in the HP-86/87 owner's documentation. Briefly, this means \otimes and \oslash operations are performed first. Then any \oplus or \ominus operations are performed. In each case, expressions are evaluated from left to right. Computed fields can contain up to five operators— \otimes , \oslash , \oplus , \ominus , or \equiv . Up to five constants or fields can be entered in the expression. Each constant or field is separated by an operator. After entering the last constant or field in the expression, press \equiv .

If a currency type field is used in the expression, then a currency type field is used for the result. This will include a floating currency sign and two decimal places. If the computed field expression does not include any currency fields, then a float type field is used. The float type field is also used when division is performed between two currency fields in the expression. A field length of 12 is used for all computed fields.

To enter an expression for a computed field, you first press **FIELD** on the REPORT LAYOUT screen. When the FIELD SELECTION screen is displayed, press **COMPUTED**. FILE/80 displays the COMPUTED FIELD screen shown on the next page. A maximum of five computed fields can be used on a report. In addition to constants and fields on the master form, you can also use the results of other computed fields in the expression you enter.

Sample Problem

A computed field is needed to measure the fraction each project of the firm CHANEY, MANN, and HILL contributes to overall profitability.

$$1 \text{ minus TOTAL AMOUNT PAST DUE divided by YTD BUSINESS VOLUME} \\ = \text{PROFIT INDEX}$$

To enter the constant 1, press **CONSTANT**, **1**, and **ENDLINE**. Then press \ominus . Next, move the cursor over the TOTAL AMOUNT PAST DUE field and press **PICK** on the COMPUTED FIELD screen. You can hold **ENDLINE** to move the cursor over this field. Press \oslash to specify division. Next, move the cursor over the YTD BUSINESS VOLUME field. Then press **PICK**.

Finally, press \equiv to end the expression. After \equiv is pressed, the PUT FIELD screen is displayed for placing the computed field on the report. This computed field is a float type field of length 12 because a ratio of two currency fields is used in the calculation.

Press **CONSTANT** (1) **ENDLINE** (-) **PICK** (/) **PICK** (=)

Form lines 45-50 ** COMPUTED FIELD ** Format: PROJECT

1-TOTAL AMOUNT / YTD BUSINESS
Please enter an operator. (+-*/=)

TOTAL HOURS ALLOTTED_***

CLIENT SINCE_***/**/**

TOTAL AMOUNT PAST DUE_***\$. YTD BUSINESS VOLUME_**\$. .

AMOUNT PAID THIS MONTH_***\$. YTD CONSULTING HOURS_**

RATE SCHEDULE 1_***\$. .

HOURS THIS MONTH 1_**

RATE SCHEDULE 2_***\$. .

HOURS THIS MONTH 2_**

1 PICK 2 CONSTANT 3 SHOW 4 RUB OUT 5 _____ 6 REPORT 7 _____

FILE/80 Display

With the following special function keys, you can specify calculations that can appear with each record on your report or separately in its heading or footing. As you enter the numbers and operations, FILE/80 builds a picture of the expression in the title/feedback window. The following special functions keys are used to enter computed fields:

PICK Press this key to use a field on the master form in a calculation. You position the cursor over the field and then press **PICK**. FILE/80 then asks you to specify an operation by pressing (+), (-), (*), (/), or (=).

CONSTANT Press this key to enter a constant from your HP-86/87 keyboard or numeric keypad. Any digits can be entered including decimals (1.234) and numbers in exponential format (1.2345E40). Then press **ENDLINE** to indicate the number has been entered.

SHOW Press this key to use the results of other computed fields in the present expression. All the computed fields you have defined so far are shown on the **SHOW COMPUTED** screen. Move the cursor over the field you need to use and press **PICK**. You can use **ENDLINE** or **(SHIFT) ENDLINE** to position the cursor. FILE/80 then asks you to specify another operator by pressing (+), (-), (*), (/), or (=).

RUB OUT Press this special function key to remove the last constant, field, computed field, or operation entered. The field or operation is then removed from the title/feedback window.

ABORT Press this special function key to clear the current computed field. The FIELD SELECTION screen is displayed. Any computed fields you could have defined earlier are unchanged.

When **⇐** is pressed, the PUT FIELD screen is displayed. Move the **Computed1** field with the cursor keys so indicators in the title/feedback window read line 10, column 64. This is the location of the leftmost position in the field. Then press **PUT**. The REPORT LAYOUT screen is then displayed.

Deleting Computed Fields

It is possible to use the results of one computed field in calculating other computed fields. Therefore, FILE/80 only allows you to delete the field which was defined last. This would be the field with the largest number. For instance, if five computed fields have been defined, only **Computed5** can be deleted. If you attempt to delete any other computed fields, a message is displayed.

Moving Fields

Fields already placed on your report can be rearranged. The current auto heading setting (page 98) determines if the field name will be placed above the field. First, the REPORT LAYOUT screen must be displayed. Press **LAYOUT** on the REPORT FORMAT screen. When the REPORT LAYOUT screen is displayed, do the following:

- a. Press **MOVE**. The MOVE FIELD screen is displayed.
- b. Press **END LINE** to move the cursor to the field you wish to move.
- c. Press **PICK**. The PUT FIELD screen is displayed.

Note: If you press **ABORT** instead of **PICK**, the REPORT LAYOUT screen is displayed.

- d. Use the cursor keys to move the field to the correct location. The field name is text, so it remains in place when the field is moved. Press **PUT**. You cannot place the field over fields already entered on a report.

Note: If you press **ABORT** instead of **PUT**, the field you selected in step c is removed from your report. The REPORT LAYOUT screen is displayed.

- e. The REPORT LAYOUT screen is displayed. The field you moved is in the position you selected in step d.

Note that after moving a numeric field, any trends designated for it must be re-entered.

Deleting Fields

Fields already placed on your report can be removed by pressing the **DELETE** special function key on the REPORT LAYOUT screen. If you are deleting computed fields, only the computed field with the largest number can be deleted. To delete a field on your report, do the following:

- a. Press **DELETE**. The DELETE FIELD screen is displayed.
- b. Press **END LINE** to move the cursor to the field you wish to delete.
- c. Press **PICK**.

Note: If you press **ABORT** instead of **PICK**, the REPORT LAYOUT screen is displayed. No fields are removed.

- d. The REPORT LAYOUT screen is displayed. The field you selected in step c is no longer on the report. However, the text of the field name is still displayed.

Entering Text

Text can be entered anywhere on your report. To enter text, the REPORT LAYOUT screen must be displayed. Simply move the cursor to the desired location and enter the text directly from the keyboard of your computer. You can remove text with **SPACE BAR** or **BACK SPACE**.

For example, to enter the title of the report on your screen you could do the following.

- a. Move the cursor to line 6, column 30.
- b. Enter the characters PROJECT SUMMARY REPORT from the keyboard.

Headings, Body, and Footings

The body for a report is designated on the REPORT BODY screen. This is done after entering the layout of a report on the REPORT LAYOUT screen. The report body is the central portion of a report. The headings and footings appear above and below the report body, respectively. Because of this, you only have to select the report body—entries above and below the report body are used for the headings and footings. The **Sample REPORT Diagram**, page 113, points out the headings, body and footings used for the PROJECT SUMMARY REPORT.

The report headings include the title of the report, a date field, and the column headings. The body of the report is made up of information from each record and subtotals, if specified. Depending on the number of lines printed with each record, more or fewer records are presented on each report page. Notice the only footing is the page number. The lines below the last field or text entry in the footing are not included in the report.

When your report is printed, the Form size (Lines) and the Printed lines per page items on the DEFAULTS screen (explained later) are used to center your report. Equal margins are left at the top and bottom of each page. The heading starts after the top margin. Then one line is inserted between the heading and the report body. The report body is printed for each successive record in your report. Then the footing is printed above the bottom margin. The headings, body, footings, and margins are indicated in the **Sample REPORT Diagram**, page 113.

If additional records remain, FILE/80 prints the same heading on the next page and prints the report body for each remaining record. The number of pages printed depend upon several factors, including the number of records in your report and the length of the report body. The same headings and footings appear on each page of your report.

To display the REPORT BODY screen, press **ACCIPI** on the REPORT LAYOUT screen. This REPORT LAYOUT screen shows the completed format for the PROJECT SUMMARY REPORT:

Press **ACCIPI**

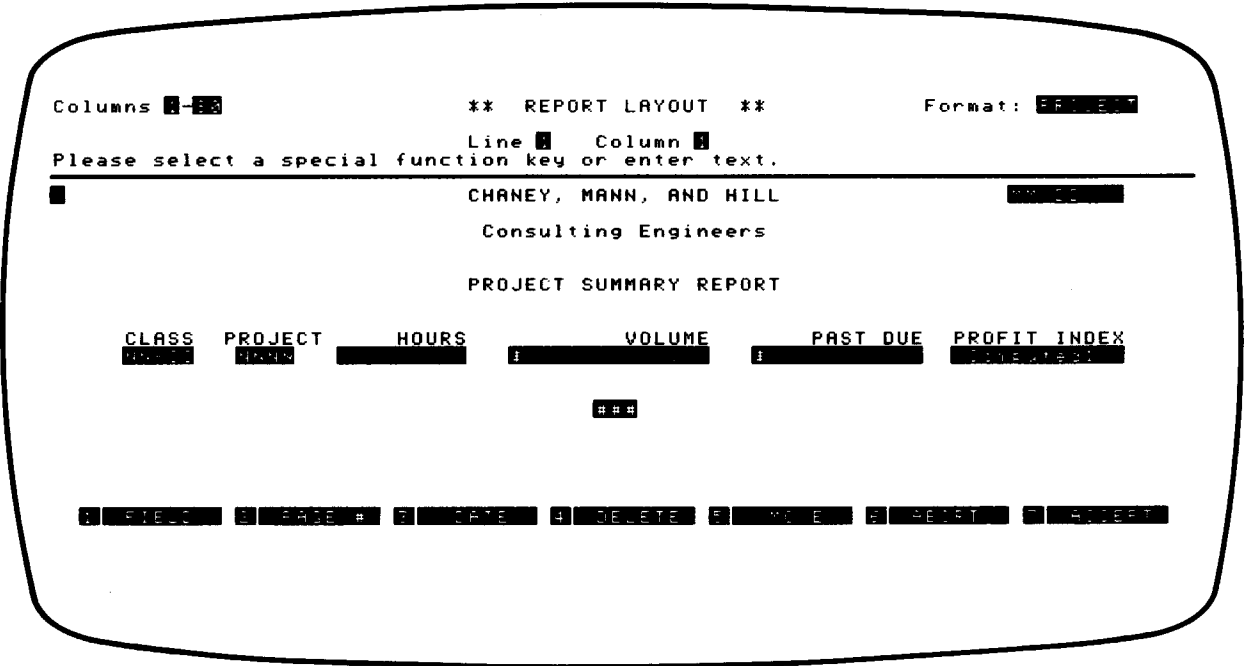

FILE/80 Display

When you press **ACCIPI** on the REPORT LAYOUT screen, the next screen is displayed. The position of the inverse video bar indicates that only the line with the fields is to appear with each record. This means that everything on the screen down to the column headings is used as the report heading. When

printing occurs, FILE/80 inserts one extra line between the last line selected for the report heading and the first record in the report body. Any text or fields on the screen below the inverse video bar are used for the report footing.

Press **FCCFP1**

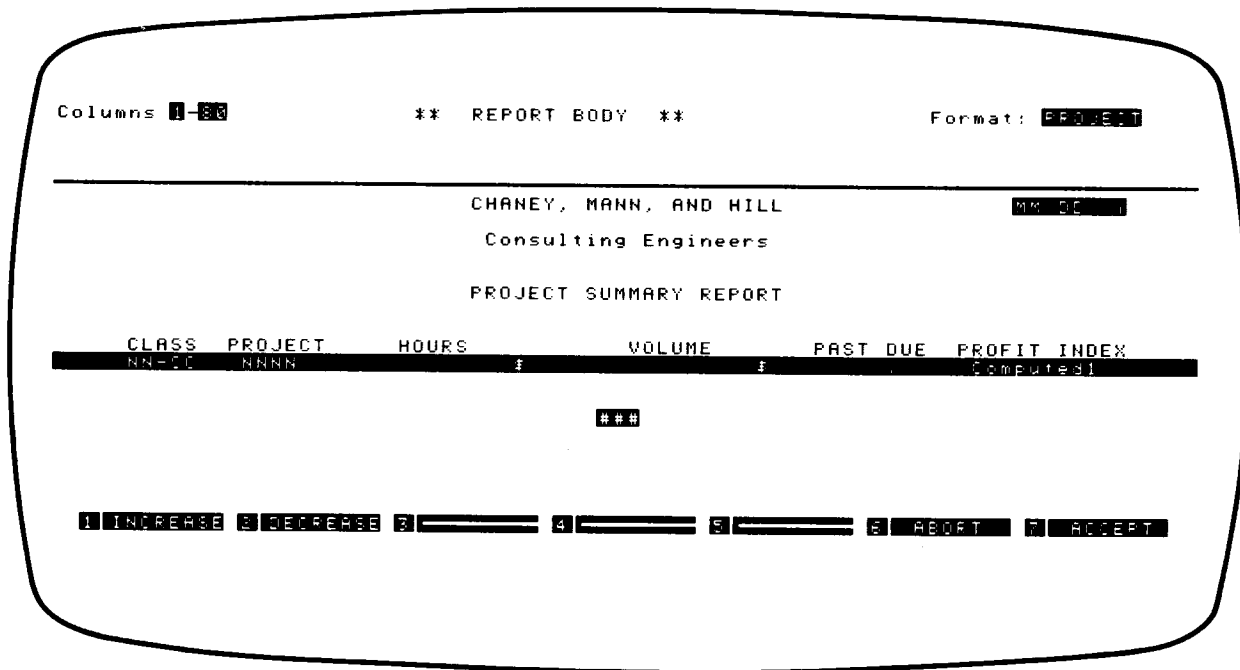

FILE/80 Display

INCREASE Press this special function key to make the inverse video bar longer, so more information can appear with each record in the body of your report. Each time you press this special function key, one line is added to the bottom of the bar. You can expand the bar to a length of 18 lines.

DECREASE Press this special function key to make the inverse video bar shorter. This means fewer lines get printed with each record on your report. When the bar first appears, it has a length of one line.

- Ⓛ Press this key to move the bar up the screen.
- Ⓧ Press this key to move the bar down the screen.
- Ⓜ Press this key to scroll the report horizontally to the left.
- Ⓨ Press this key to scroll the report horizontally to the right.

ABORT Press this key to display the REPORT LAYOUT screen. With this screen, modifications to the fields and text on your report can be made.

ACCEPT Press this key to designate the body of your report. The inverse video bar should exactly cover the lines you want to appear with each record in your report. The REPORT FORMAT screen is displayed.

Ordering Your Report

The SORTED REPORT screen is used to specify the printing order of records. This is so similar records can be grouped together. You can choose up to five fields on your master form to order the report. These fields are designated as ascending or descending. They do not have to be included in the report.

Note: It is only necessary to specify sort fields for reports printed in primary key order when you wish to designate when new pages or subtotals are to be printed with the **BREAKS** special function key. Refer to **Designating Break Types**, page 109.

The SORTED REPORT screen is displayed when you press **SORT** on the REPORT FORMAT screen. The numbers displayed in the title/feedback window are used to specify the order of the sort fields. To designate the CLASSIFICATION field as an ascending sort field you move the cursor over it and press **ASCEND**. Press **ENDLINE** to move the cursor. After all sort fields have been specified, press **ACCEPT**.

Press **ASCEND** **ACCEPT**

```

Form lines 01-99          ** SORTED REPORT **          Format: PROJECT
1. CLASSIFICA

-----

LAST CONTACTED_** **/ **/ **
PROJECT** ** **
CLASSIFICATION** ** **

CONSULTING REQUIREMENTS_** **
PROFITABILITY INDEX_** **
1. Subtract TOTAL AMOUNT PAST DUE from YTD BUSINESS VOLUME.
2. Divide difference obtained by YTD BUSINESS VOLUME.
PROJECT FROM_** **/ **/ ** TO_** **/ **/ **
TOTAL HOURS ALLOTTED_** **

1 ASCEND 2 DESCEND 3 UNDO 4 _____ 5 _____ 6 ABORT 7 ACCEPT

```

FILE/80 displays your master form in the information window of the SORTED REPORT screen. Using the same process you did when picking primary and secondary key fields, you can choose up to five ascending or descending sort fields from the master form. Just move the cursor over the field(s) and press the appropriate special function keys:

ASCEND / DESCEND Press these special function keys to designate the field the cursor is over as the next sort field. These fields display an **A** or **D** in the search/sort indicator. The field names appear beside the next number in the title/feedback window.

Note: The sort field beside the smaller number in the title/feedback window determines the overall ordering of records. You can refer to **Comparison of Field Entries**, page 68, to determine the ascending or descending order for different types of fields.

UNDO Press this special function key to clear the sort field the cursor is over. FILE/80 updates the list in the title/feedback window. Whenever any field but the last one is removed, the remaining sort fields move up one place—there are no gaps in the sort field list.

ABORT Press this special function key to clear all sort fields and display the REPORT FORMAT screen.

ACCEPT Press this special function key when you've defined all the sort fields necessary for your report. The REPORT FORMAT screen is then displayed. When your report is printed, each record included in it appears in the order of the sort fields you just defined.

Sort Fields

The fields you choose for sorting determine whether or not time is required for sorting when your report is produced. When the order you specify is the same as key fields for your file, then no time for sorting is required. If a secondary key field is used, it should be the only sort field designated. If primary key fields are used, one through four of the primary key fields can be designated. However, one of these orderings is needed.

- Primary key fields 1, 2, 3, and 4.
- Primary key fields 1, 2, and 3.
- Primary key fields 1 and 2.
- Primary key field 1.

In addition, the primary key fields used must be designated as all ascending sort fields or all descending sort fields.

When time is required for sorting, the combined length of all fields designated as sort fields influences the amount of time needed. When the combined length of the sort fields is small, less time is required for sorting. When the combined length is greater, more sorting time is required. Refer to appendix B for specific information regarding the length of sort fields.

Once an output format has been sorted, the specific ordering of records can be used again with the `Reuse sorted list` default. The sorted list kept for each file can be used by any output format defined for that file. Refer to page 119 for details.

Designating Break Types

After you have designated at least one sort field, the `BREAKS` special function key appears on the `REPORT FORMAT` screen. When you press `BREAKS`, the `BREAK FIELDS` screen is displayed. This screen gives you a way to analyze the information stored in your file. Sorted data can be grouped with subtotals or printed on separate pages. When data changes or “breaks” in a sort field designated on the `BREAK FIELDS` screen, this sequence occurs:

- a. Any subtotals are printed.
- b. If the break occurs in a page break field (explained shortly), your printer advances to the next page and prints report headings.
- c. The next record is printed.

Breaks occur when records are being printed on reports. When the information changes in a sort field you designate on the `BREAK FIELDS` screen, a break occurs. You can only designate sort fields that were specified on the `SORTED REPORT` screen. If no sort fields have been chosen, no break fields can be designated.

This portion of the `PROJECT SUMMARY REPORT` indicates the occurrence of breaks. When subtotals are specified they are printed just after a break occurs, before the next record is printed.

	Break Field	Subtotal Field
	↓	↓
	CLASS PROJECT	HOURS
	01-CS 1202	320
	0206	4
	0207	7
	0307	13
	1701	11
BREAK	Subtotals:	355
	02-MD 1101	210
	1102	80
	.	.
	.	.
	.	.

Break Diagram

Breaks occur when the information in any break field changes. Specifically, a break occurs when the information in a break field on the next record isn't equal to the information in the same field of the record currently being printed. You can examine the information in the CLASSIFICATION field to verify that a change occurred—this is indicated in the **Break Diagram**.

There are two types of break fields, control break fields and page break fields. The break shown in the **Break Diagram** occurs in a control break field. With page break fields, the next record is printed at the top of the next page (after the headings) instead of being printed on the same page.

If you specify subtotals for your report, they are printed whenever the value in a break field changes. If the field changing is a page break field, then a new report page is started after the subtotals are printed.

When you press **BREAKS**, this screen is displayed. To designate the **CLASSIFICATION** field as a control break field, press **CONTROL**:

Press **CONTROL** **ACCEPT**

```

** BREAK FIELDS **                               Format: PROJECT
-----
Field_name      Break_type
*****
1. CLASSIFICA   Control
  
```

1 CONTROL 3 PAGE 2 UNDO 4 _____ 5 _____ 6 ACCEPT 7 ACCEPT

FILE/80 Display

The list of fields on the **BREAK FIELDS** screen is identical to the one displayed in the title/feedback window of the **SORTED REPORT** screen. The cursor always appears in the **Break_type** column. Because break fields are designated in sort field order, you can only move the cursor forward in the list after designating break fields. Use **ENDLINE** or **SHIFT** **ENDLINE** to move the cursor to different break fields.

CONTROL Press this key to specify that a break should occur when the information in the sort field opposite the cursor changes. If you have specified subtotals, they will also be printed at this time.

Note: The fields that subtotals are printed for are specified on the **REPORT TRENDS** screen.

PAGE Press this key if you want records after the break to start on the next page.

UNDO Press this key to clear the last sort field you designated as a break field on the screen. The cursor needs to be opposite this field when you press **UNDO**.

ABORT Press this key to clear all the sort fields designated as break fields. The REPORT FORMAT screen is displayed.

ACCEPT Press this key after designating all break fields. The REPORT FORMAT screen is displayed.

Sort Fields, Breaks, and Subtotals

The number of sort fields you designate as break fields depends on how often you want subtotals to be printed on your report. All subtotals you designate are printed whenever the information in a break field changes. The field causing the break determines what records are included in each subtotal.

When a change occurs in the first break field, all the records printed since the last change in this field are included in the subtotal, for example. If changes occur in several break fields, the break field with the lower order determines which records are included in the subtotal. On the **Sample REPORT Diagram**, arrows indicate which records are included when breaks are caused by changes in the CLASSIFICATION field.

Note: At the end of this section, all the sort fields, break fields, and subtotals specified for this report are listed.

Report Trends

The REPORT TRENDS screen is used to make your report more useful by providing grand totals, subtotals, averages, and minimum/maximum values for numeric fields appearing on your report. To summarize your report with any of these items, press **TRENDS** on the REPORT FORMAT screen.

To specify subtotals for the YTD BUSINESS VOLUME field, move the cursor over this field and press **SUB**. You can press **END LINE** or **(SHIFT) END LINE** to move the cursor. When all other trends have been entered, press **ACCEPT**.

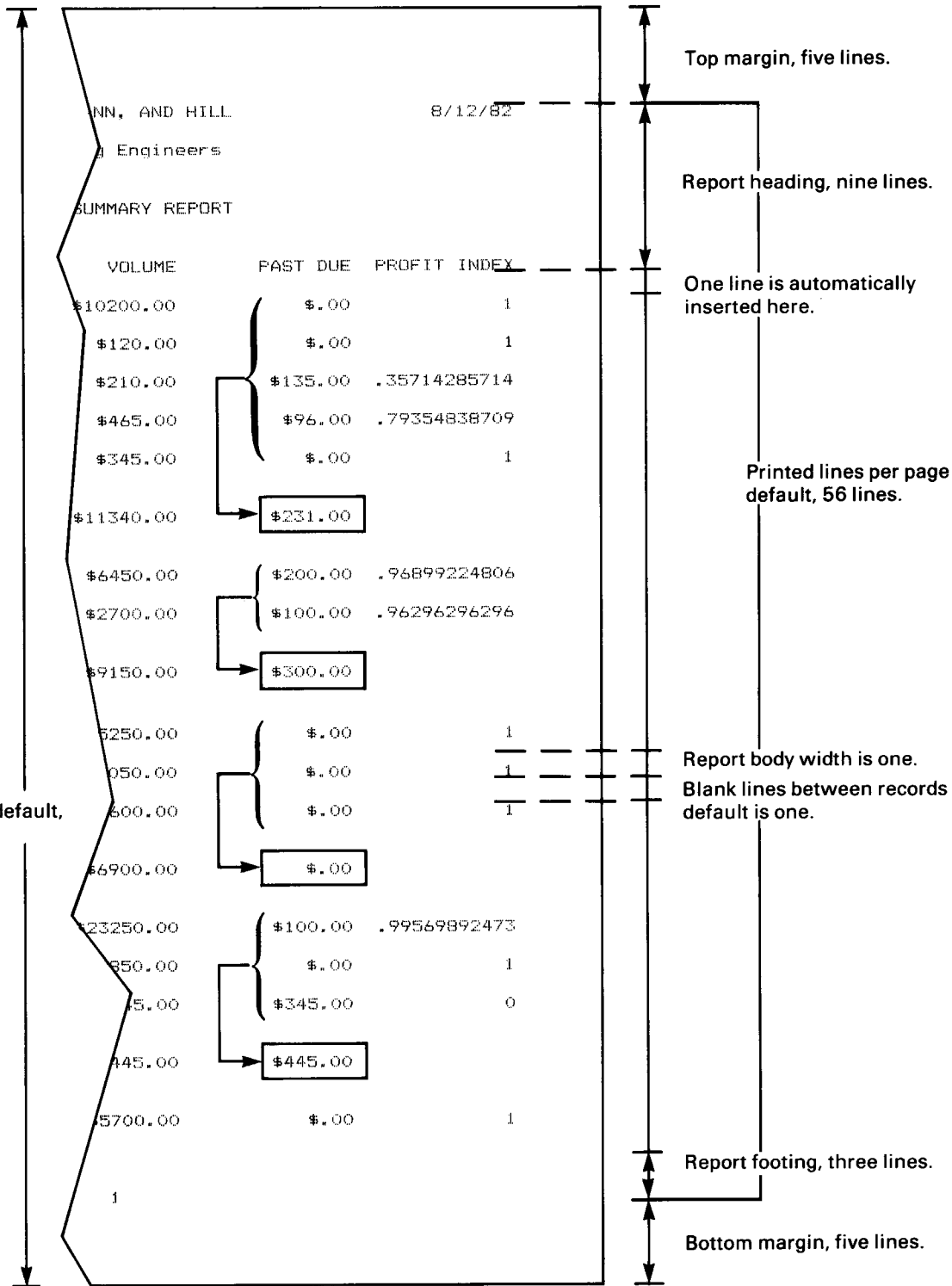

Sample REPORT Diagram

Press **SUB** **ACCEPT**

```

Columns: 1-80          ** REPORT TRENDS **          Format: PROJECT
Field:  YTD BUSINESS
1.          2. SUB          3.          4.

-----
CHANEY, MANN, AND HILL
Consulting Engineers

PROJECT SUMMARY REPORT

CLASS  PROJECT  HOURS  VOLUME  PAST DUE  PROFIT INDEX
NN-CC  NNNN      #      $      $      COMPUTED

###

1. GRAND  2. SUB  3. MEAN  4. MIN-MAX  5. UNDO  6. REPT  7. ACCEP

```

FILE/80 Display

FILE/80 displays a listing of trends selected for the field the cursor is over in the title/feedback window. Any fields on your report with trends are indicated by the character ***** in the leftmost position. To see what trends are selected for a field, simply press **(END LINE)** or **(SHIFT) (END LINE)** to move the cursor over the field. Trends can only be specified for integer, currency, float, or computed fields. With the exception of subtotals, all trends are printed at the end of your report.

Up to four different trends can be specified for a single field. Grand totals can be specified on 15 fields of your report. Five subtotals, five averages, and five minimum/maximum values can also be specified. Grand totals and subtotals are specified for the **YTD BUSINESS VOLUME** field on the **PROJECT SUMMARY REPORT**.

When the cursor is over a numeric field, you can select trends for it by pressing these special function keys:

GRAND Press this special function key to designate totals including each record on your report. Move the cursor over any field you want a total for and press **GRAND**. If the total is three or more digits over the field designated, the amount printed as the grand total will not be correct. FILE/80 prints an asterisk in the rightmost position of the field to indicate that an overflow has occurred.

SUB Press this special function key to specify subtotals for the field the cursor is over for your report. Subtotals are printed when breaks occur and will not be printed unless you specify at least one break field on the **BREAK FIELDS** screen. If the value for a subtotal is three or more digits

larger than the field, FILE/80 prints an asterisk in the rightmost position of the field to indicate an overflow has occurred. This means the amount printed is not correct.

Note: You should leave three blanks to the left of fields with subtotals and/or grand totals to provide room for this overflow. If necessary, refer to **Moving Fields** on page 103 for instructions.

MEAN Press this special function key to include an average for the field the cursor is over at the end of your report.

MIN/MAX Press this key to include the minimum and maximum values occurring in the field the cursor is over. These values are printed at the end of your report.

UNDO Press this key to clear all trends for the field the cursor is over.

ABORT Press this key to clear all the trends specified for your report. The REPORT FORMAT screen is displayed.

ACCEPT When you've entered all the trends needed to summarize your report, press **ACCEPT**. FILE/80 displays the REPORT FORMAT screen.

Note that if you move a field with trends—identified by the character *—all trends for the field must be re-entered.

Storing Reports

When you are finished defining your report, press **DONE** on the REPORT FORMAT screen to store your report format. The format disc file is stored in the first empty space large enough on-line. The number of output formats that can be stored is only limited by the amount of disc space available. Printed reports can only be produced from formats that have already been stored on disc. Once your format is stored, the PRINT SPECIFICATIONS screen is displayed.

Printing Reports

FILE/80 uses two screens to help you produce specific reports easily. These are the REPORT and PRINT SPECIFICATIONS screens. The PRINT SPECIFICATIONS screen is displayed in several cases. It is displayed after you press **DONE** on the REPORT FORMAT screen. The PRINT SPECIFICATIONS screen is also shown if you enter a name of an output format that is on-line when the OUTPUT screen is displayed.

Note: If you press **DUMP ALL** on the OUTPUT screen, the PRINT SPECIFICATIONS screen is displayed. However, only the **DEFAULTS**, **ABORT**, and **PRINT** special function keys are present. Instead of the REPORT screen, the DUMP ALL screen is displayed after pressing **PRINT**. Refer to **Printing With the Report Screen** on page 119 for instructions on using the DUMP ALL screen.

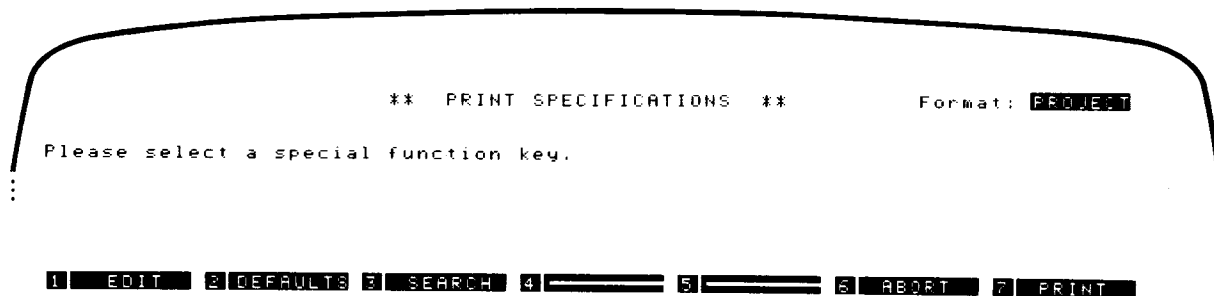

FILE/80 Display

There are five special function keys on the `PRINT SPECIFICATIONS` screen:

EDIT Press this special function key to make modifications to your output format. A message is displayed requesting you to enter the name of the new output format. If you enter a name different than the format currently being accessed, an additional format (with your revisions) will be stored on disc. If you enter the same name, your original output format is modified.

After entering the new format name, the `REPORT FORMAT` screen is displayed. Making changes to an existing report is easy because you use the same special function keys to edit a report as you do to create one. Refer to **Changing Reports** on page 122 for instructions.

DEFAULTS Press this special function key to display the output specifications for the current output format. Instructions for changing these parameters follow. Once set, defaults for each output format remain in effect from one session to the next.

Note: If **DUMP ALL** was pressed, you will have to reset the defaults.

SEARCH Press this special function key to select a group of records for printing in a report. This key is identical to the **SEARCH** key on the `QUERY` screen. For example, if you only wanted records for a specific client on a report, you could enter his name in the `LAST NAME` field. Once you enter the search conditions and press **ACCEPT**, the `PRINT SPECIFICATIONS` screen is displayed. For more information, refer to the **SEARCH Screen Summary** on page 86.

ABORT Press this special function key to display the `OUTPUT` screen. You can then press **ABORT** on the `OUTPUT` screen to display the `FILE/80` screen.

PRINT Press this special function key to start the processing and printing of the records selected for your report. If sorting is required, the `SORT` screen is displayed while it is performed. Otherwise, the `REPORT` screen is displayed. Before pressing **PRINT**, make sure `FILE/80` has the correct address of your printer by pressing **DEFAULTS**.

Report Defaults

After pressing **DEFAULTS** on the PRINT SPECIFICATIONS or REPORT screen, this **DEFAULTS** screen is displayed. There is a different list of default items for each type of output format. To implement a change, position the cursor over the number beside the appropriate default and press **CHANGE**. You can press **END LINE** or **SHIFT END LINE** to move the cursor. When you press **CHANGE**, a prompt for the new default is displayed in the title/feedback window.

Note: If **DUMP FILE** was pressed on the **OUTPUT** screen for printing file records, then only the Printer address, Printer type, and Maximum records per page defaults are present. Settings for these items are explained with the other report defaults.

For example, to change the Blank lines between records report default from 1 to 0, press **END LINE** repeatedly until the cursor is on the number beside this item. Next, press **CHANGE** followed by the digit 0 and **END LINE**. Make all changes necessary, and then press **ACCEPT**.

Press **CHANGE** **0** **END LINE** **ACCEPT**

```

** DEFAULTS **                               Format: REPORT
-----
1. Printer address: 000
2. Printer type: 1
3. Number of copies: 1
4. Stop between pages: 200
5. Form size (Lines): 66
6. Printed lines per page: 64
7. Blank lines between records. 1
8. Reuse ordered list: 0

1 CHANGE 2 END LINE 3 SHIFT END LINE 4 ACCEPT

```

When you press **ACCI P I**, the setting for each item is changed to whatever is displayed in the list and then the PRINT SPECIFICATIONS screen is displayed. The valid entries for each default item are as follows:

Printer address: The default setting is 701.

Printer type: Refer to appendix C.

Number of copies: 1 to 99 copies are permitted. The default setting is 1. If you specify multiple copies, one complete report is produced. Then the copies are printed.

Stop between pages: YES, NO. The default setting is NO. If you select this item, you can press **CONTINUE** on the REPORT screen to resume printing of your report after each page is printed. This enables you to use non-continuous paper forms for printing.

Form size (Lines): 1 through 99 are permitted. This is the number of lines that are printed on a page before a page eject is sent to your printer. The default setting is 66. This is the number of lines on standard size paper forms. If you are using shorter or longer forms, you'll need to change this item.

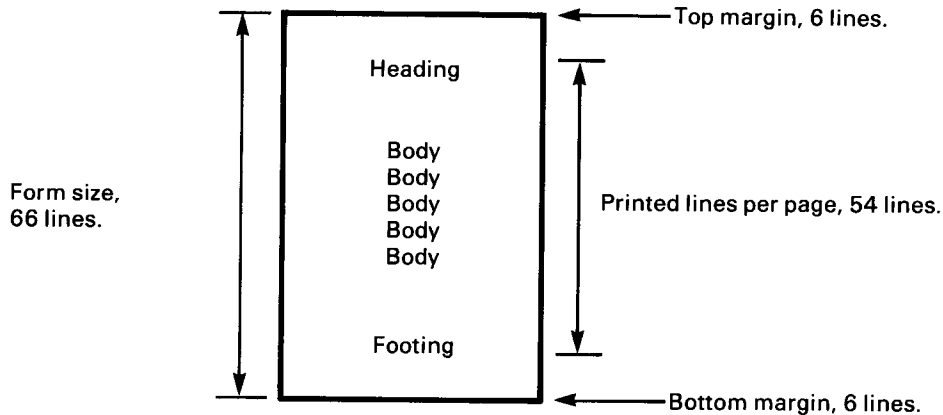

Printed lines per page: 1 through 99 are permitted. The default setting is 54. Your report is centered on the page according to this default. A six line margin is provided at the top and bottom of each page with the preset defaults for Form size and Printed lines per page.

Note: You cannot enter a setting for Printed lines per page that is greater than the current Form size setting.

Blank lines between records: 0 through 9. The default setting is 1. These lines are inserted after each record is printed.

Reuse sorted list: YES, NO. The default setting is NO. If you change this item to YES, no sorting is performed. Instead, the order of records is determined by a sorted list of records used for a previous output format. Any current sort fields or search conditions are disregarded.

You must set this item to YES each time you want to use the sorted list. When you change this item to YES, a message is displayed giving the number of additions, updates, and deletions in your file since the sorted list was generated. If a valid sorted list doesn't exist for your file, then the Reuse sorted list default is not present.

The sorted list is generated whenever the default setting is NO and the output format being printed has at least one sort field. Depending on the sort field(s), the sorted list can be generated at two different times:

- A sorted list is generated when the SORT screen is displayed after pressing **PRINT**.
- If the SORT screen is not displayed after pressing **PRINT**, a sorted list is generated during initial printing while the REPORT screen is displayed.

Note: If **ABORT** is pressed on either the SORT or REPORT screens while a sorted list is being generated, the list becomes invalid.

Maximum records per page: This item is only present when **DUMP ALL** is pressed on the OUTPUT screen. The default setting is YES—multiple records per page. If you change the setting to NO, then one record is printed per page.

Printing With the REPORT Screen

To start printing a report press **PRINT** on the PRINT SPECIFICATIONS screen. FILE/80 displays the following REPORT screen. As your report is printed, it is also displayed on the REPORT screen. You can turn either the display or printer off (but not both) by first pressing **PAUSE** and then pressing either **DISPLAY** or **PRINTER**. Then press **CONTINUE**.

Note: If sorting is required for your report, the SORT screen is displayed first. When sorting is complete, the REPORT screen is displayed.

Printing record #5 PRINTING IS ON
 Printing Format: PROJECT DISPLAY IS ON

PROJECT SUMMARY REPORT

CLASS	PROJECT	HOURS	VOLUME	PAST DUE	PROFIT INDEX
01-CS	1202	320	\$10200.00	\$.00	1
	0206	4	\$120.00	\$.00	1
	0207	7	\$210.00	\$135.00	.35714285714
	0307	13	\$465.00	\$96.00	.79354838709
	1701	11	\$345.00	\$.00	1
Subtotals for: 01-CS		355	\$11340.00	\$231.00	

1 PAUSE 2 _____ 3 _____ 4 _____ 5 _____ 6 ABORT 7 _____

FILE/80 Display

If you press **ABORT**, the special function window on the **REPORT** screen changes. The same window is displayed after the last record of a report has been printed.

CONTINUE Press this key to resume printing.

EDIT Press this key to display the **REPORT FORMAT** screen. Refer to page 122 for details.

SPECS Press this key to display the **PRINT SPECIFICATIONS** screen.

OUTPUT Press this key to access file records or other output formats. The **OUTPUT** screen is displayed.

XIT Press this key to return your HP-86/87 to calculator mode.

If you press **PAUSE**, the following screen is displayed.

```

Printing record #8
Printing Format: PROJECT
** REPORT **
PRINTING IS ON
DISPLAY IS ON
-----
0206      4      $120.00      $ .00      1
0207      7      $210.00      $135.00    .35714285714
0307     13      $465.00      $96.00    .79354838709
1701     11      $345.00      $ .00      1
Subtotals for: 01-CS      355      $11340.00      $231.00
02-MD 1101     210      $6450.00      $200.00    .96899224806
      1102      80      $2700.00      $100.00    .96296296296
Subtotals for: 02-MD     290      $9150.00      $300.00
1 CONTINUE 2 _____ 3 _____ 4 DISPLAY 5 PRINTER 6 ABORT 7 RESTART

```

FILE/80 Display

These special function keys are displayed when printing is paused:

CONTINUE Press this special function key to resume printing your report.

DISPLAY Press this special function key to change the **DISPLAY IS ON/OFF** indicator in the title/feedback window.

PRINTER Press this special function key to change the **PRINTING IS ON/OFF** indicator.

ABORT Press this special function key to display the **CONTINUE**, **EDIT**, **SPECS**, **OUTPUT**, and **EXIT** special function keys. These are covered on page 120.

RESTART Press this special function key to start printing the report over again. The **REPORT** screen with the **PAUSE** and **ABORT** keys is displayed.

Changing Reports

If you wish to make changes to a new or existing output format, you can press the **F11** special function key on the PRINT SPECIFICATIONS screen. This key is also displayed on the REPORT screen after a report has finished printing. Perhaps you wish to change the title of your report. After you press **F11**, a prompt is displayed in the title/feedback window of the PRINT SPECIFICATIONS screen for a new format name:

- If you enter a different name than the output format currently being accessed, a separate revised format is stored on disc when you finish changing the report.
- If you enter the same name as the format being accessed, the original version is modified.

After you enter the new format name and press **ENDLINE**, FILE/80 displays the REPORT FORMAT screen.

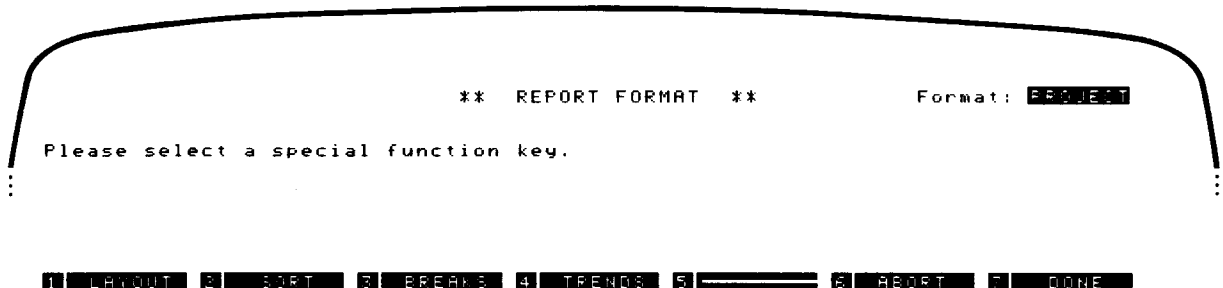

FILE/80 Display

When you are finished modifying the output format, press **DONE** on the REPORT FORMAT screen. If you entered the original name for the output format, only the new version is accessible after pressing **DONE**. The PRINT SPECIFICATIONS screen is displayed after you press **DONE**, as usual. Refer to **Report Definition** on page 92 for instructions on using the REPORT FORMAT screen. Any changes except the format type can be made to an output format.

CLIENTS File Output Format: *REPORT*

Fields

The location of the field is indicated by the line and column counters on the REPORT LAYOUT screen.

	Line	Col.
Date field obtained by pressing DATE	1	68
CLASSIFICATION (with auto heading)	9	6
PROJECT	10	14
YTD CONSULTING HOURS	10	21
YTD BUSINESS VOLUME	10	33
TOTAL AMOUNT PAST DUE	10	50
Computed 1 = 1 minus TOTAL AMOUNT PAST DUE divided by YTD BUSINESS VOLUME	10	64
Page number field obtained by pressing PAGE #	13	39

Text Entries

CHANEY, MANN, AND HILL	1	30
Consulting Engineers	3	31
PROJECT SUMMARY REPORT	6	30
PROJECT	9	13
HOURS	9	25
VOLUME	9	41
PAST DUE	9	54
PROFIT INDEX	9	64

Headings and Footings

On the REPORT BODY screen, place the inverse video bar over the line that contains all the fields, immediately after the column headings. The bar should have a width of 1 when **ACCEPT** is pressed.

Sort Fields

Move the cursor over the CLASSIFICATION field and press **ASCEND**.

Break Types

Press **CONTROL** when the cursor is positioned beside the CLASSIFICATION field. Then press **ACCEPT**.

Trends

YTD CONSULTING HOURS **SUE**
YTD BUSINESS VOLUME **GRANT , SUE**
TOTAL AMOUNT PAST DUE **GRANT , SUE**

Defaults

The following defaults are set on the DEFAULTS screen, after pressing **DONE** on the REPORT FORMAT screen. To enter defaults, press **DEFAULTS** on the PRINT SPECIFICATIONS screen.

Printer address Set this default to your printer address.

Printer type Set this default to your printer type. Refer to appendix C.

Number of copies: 1

Stop between pages: NO

Form size (Lines): 66 However, if you are using non-standard forms, this item should be changed to the number of lines on a form.

Printed lines per page: 56 This setting should not exceed the previous default.

Blank lines between records: 1

Reuse sorted list: NO

Notes



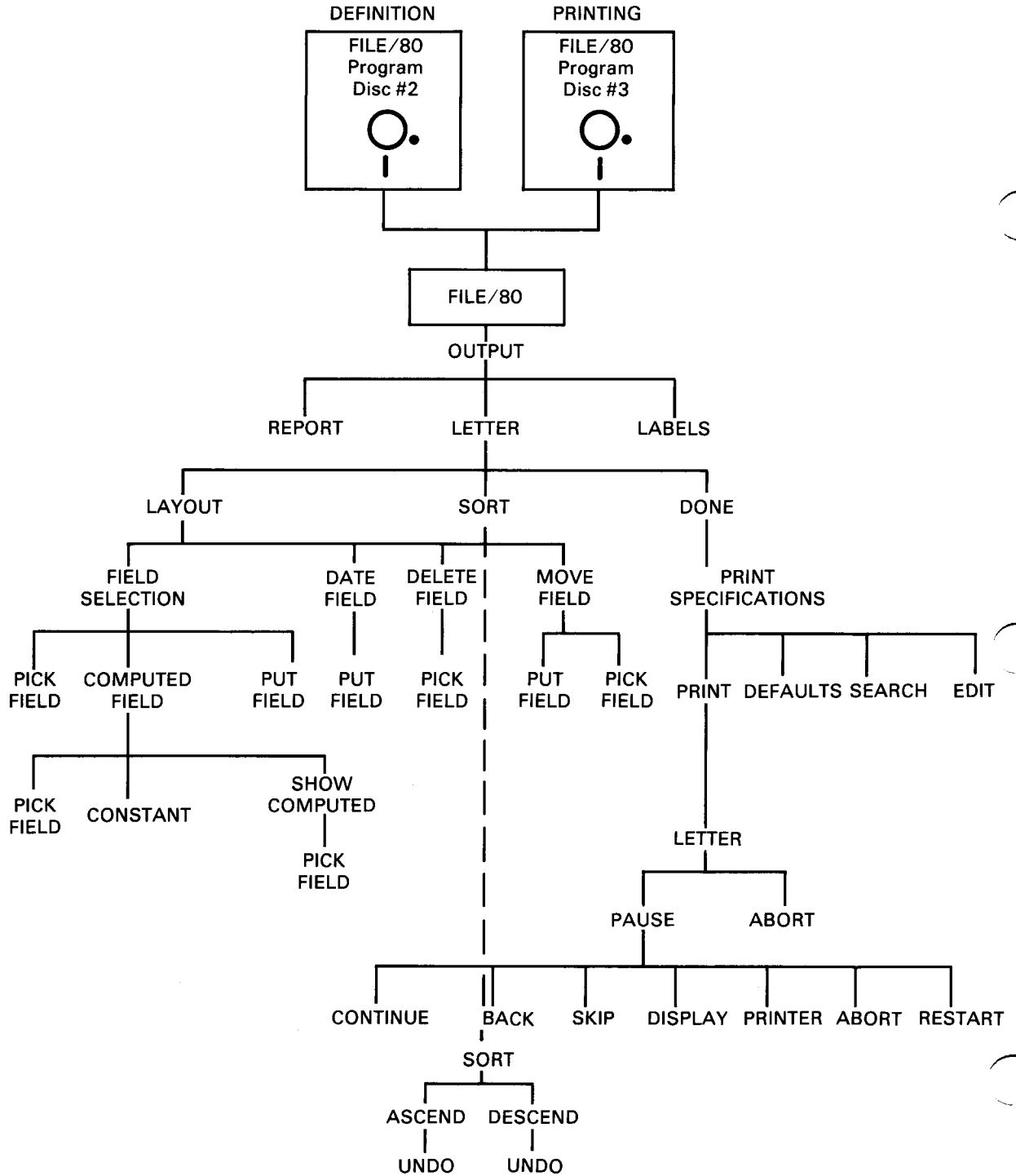

LETTER Diagram

Generating Letters

In this section you learn how to generate letters. The sample letter shown in the overview is defined and printed in this section. FILE/80 uses a different record in your file to print each letter. Letters can be up to 60 lines long and have a width of 80 columns. Computed fields can be used on letters. You can also select which records in your file to print letters for, and then specify the printing order. To define and print the sample letter, you will need the following:

- FILE/80 Program Disc #2
- FILE/80 Program Disc #3
- FILE/80 Demonstration Disc

Discs containing the file for which a letter is specified must be on-line when the letter is defined.

Use of FILE/80 Program Discs

Only one FILE/80 program disc needs to be used at a time. Although you can load the FILE/80 program from any disc, it is recommended you do the following:

- To define or edit a letter, use FILE/80 Program Disc #2.
- To print letters, use FILE/80 Program Disc #3.

Whenever a disc not on-line is needed, FILE/80 prompts you to insert it.

Introduction

Letters can be printed for every record in your file or for specific groups of records. With the SEARCH screen, you can choose groups of records from your file. Only those records satisfying the conditions you enter are used for printing letters. The LETTER output format for the CLIENTS file only prints letters for clients contacted later than 06/30/82, for example. Letters can be produced in a specific order, such as by zip code, when designated on the SORTED LETTER screen.

The definition of a letter starts when you enter a format name on the OUTPUT screen, such as MEMO, and press **LETTER** on the OUTPUT TYPE screen. You can enter text anywhere on the letter. Fields are selected from the master form on the LETTER LAYOUT screen. You can position the field anywhere on the document by pressing the cursor keys.

FILE/80 displays the letter being defined on the LETTER LAYOUT screen. This enables you to see exactly how the letter looks before it is printed. Because it is displayed in final form, the design of each letter is a paperless process. Enter text or fields on your screen the same way you want them to appear on the hard-copy letter.

Letter Definition

To define any output format, the file used to produce the letters must be accessed. To do this, you must first load FILE/80 and press **RUN**. A FILE/80 Program Disc needs to be in the default drive when **RUN** is pressed. To participate in the examples in this section, the FILE/80 Demonstration Disc should be on-line. When the FILE/80 screen is displayed, press **OLD FILE** and enter the name of the file you wish to produce letters from. To define the letter shown in the overview, the name CLIENTS should be entered. The password is HP. After pressing **ACCEPT** to verify that the list of MSUSs is correct, this screen is displayed. To begin the definition of an output format, press **OUTPUT**:

Press **OUTPUT**

```

FILE NAME: CLIENTS          ** FILE/80 **          TODAY'S DATE: 08 13 82
Please select a special function key.
:
1 QUERY  2 OUTPUT  3 REDEFINE  4 TABS  5 DEFAULTS  6 EXIT  7 DONE

```

FILE/80 Display

Accessing Output Formats

A format name is needed to identify your reports, letters, or labels on disc. This name can contain any upper or lower case letters or digits and has a maximum length of eight characters. Whenever you enter the name of an output format, FILE/80 checks to see if a disc file beginning with the name entered and ending with the characters `_T` is on-line.

- If the disc file is present, then the **PRINT SPECIFICATIONS** screen is displayed.
- If the disc file isn't on-line, the **OUTPUT TYPE** screen is displayed.

If you enter the name of an output format incorrectly, press **ABORT** on the **OUTPUT TYPE** or **PRINT SPECIFICATIONS** screens to re-enter the name on the **OUTPUT** screen.

The output format described in this section is identical to the LETTER output format stored on the FILE/80 Demonstration Disc. Since this disc must be on-line, a different name must be used. Any upper or lower case letters or digits can be used for a format name—maximum length is eight characters. To enter the name of a letter output format called MEMO, press these keys:

Press (M) (E) (M) (O) (ENDLINE)

```

** OUTPUT **
FORMAT NAME? MEMO
1 DUMP ALL 2 _____ 3 _____ 4 _____ 5 _____ 6 ABORT 7 _____

```

FILE/80 Display

FILE/80 displays the OUTPUT TYPE screen. Press (LETTER) on the OUTPUT TYPE screen to start the definition of a letter output format. The LETTER FORMAT screen is displayed:

```

** LETTER FORMAT **          Format: MEMO
1 LAYOUT 2 ABORT 3 _____ 4 _____ 5 _____ 6 ABORT 7 _____

```

FILE/80 Display

These special function keys are provided:

LAYOUT Press this key to enter fields and text on your letter. The LETTER LAYOUT screen is displayed.

SORT Press this key if you want your letters printed in a certain order. Up to five fields on the master form can be used to determine this ordering. When no order is specified, your records are printed in primary key order.

ABORT Press this key to clear the letter and display the OUTPUT screen.

DONE Press this key to store the letter. The PRINT SPECIFICATIONS screen is displayed. This key doesn't appear until at least one field has been placed on your letter.

Letter Layout

Letters are designed on the screen of your HP-86/87. The layout you choose depends on your application. In most cases, text suitable for everyone receiving the letter is entered. Fields can be placed on the letter for a personal touch. Either computed fields you define or fields directly from the master form can be used. FILE/80 provides a current date field also. By choosing the correct combination of fields and text you design a layout that makes each letter personalized and informative.

Fields can be placed anywhere on your letter. You can place a maximum of 100 fields on your letter. Text can be entered anywhere on your screen. Up to 4,800 characters of text can be used. A listing of all the fields and text used for the sample letter shown in the overview is provided at the end of this section.

To enter fields and text on a letter, press **LAYOUT** on the LETTER FORMAT screen. This screen is displayed:

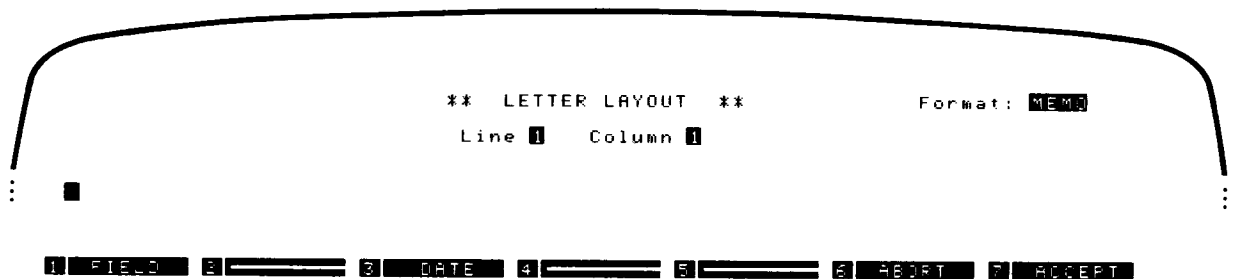

It's easy to design specific letter formats with the `LETTER LAYOUT` screen. You enter text where you want it to appear on the printed letter from the keyboard of your HP-86/87 and use the screen to design the layout. You can select fields for your letter from the master form.

These special function keys are available:

FIELD Press this special function key to add a field to your letter. When you press **FIELD**, the `FIELD SELECTION` screen is displayed. Any field can be chosen from the master form with **PICK** or you can begin definition of a computed field by pressing **COMPUTED**.

Note: When positioning fields on your letter, you should consider how `FILE/80` justifies letters when they are printed. Details are provided under **Use of Justify Mode**, page 136.

DATE Press this special function key to include a date field on your letter. The `PUT FIELD` screen is displayed so you can place the field in the correct location on your letters. If you put this field on your output format, the current date is printed on each letter.

DELETE Press this special function key to remove any field on your letter. `FILE/80` displays the `DELETE FIELD` screen. You move the cursor over the field you wish to delete with `END LINE` and press **PICK**. If you press this key accidentally, press **ABORT** on the `DELETE FIELD` screen.

Note: Details on removing computed fields are provided under **Deleting Computed Fields** on page 103.

MOVE Press this special function key to rearrange fields on your letter. The `MOVE FIELD` screen is displayed. Position the cursor over the field you wish to move and press **PICK**. When the `PUT FIELD` screen is displayed, you just move the field to the desired location with the cursor keys and press **PUT**.

ABORT Press this key to clear the layout of your letter.

ACCEPT Press this special function key when you are finished defining the letter's appearance. The `LETTER FORMAT` screen is displayed.

After pressing **ACCEPT**, you can choose the printing order of your records with **SORT**, or you can press **DONE** to store the new letter output format on disc. `FILE/80` prints your letters in primary key order unless you specify otherwise with **SORT**. Since the printing order is included with your output format, this decision should be made before pressing **DONE**.

Text

When the blinking cursor appears in the information window of the LETTER LAYOUT screen, you can place text on your letter. Any non-control HP-86/87 keyboard characters can be used. Simply position the cursor where the text is to be entered and type it in. Text can be erased from your letter by moving the cursor over it with **SPACE BAR** or **BACK SPACE**. Text is also removed when a field is placed over it on the PUT FIELD screen.

FILE/80 indicates the position of the cursor by displaying line and column counters in the title/feedback window of the LETTER LAYOUT and PUT FIELD screens. The line counter ranges from 1 to 60. The column counter ranges from 1 to 80. Besides **↑** and **↓**, the following keys can be used to scroll the letter. When the letter is scrolled, the cursor moves with it but always stays on the screen.

ROLL Scrolls the letter. The cursor stays in the same column.

CONT Displays the next 15 lines of the letter. The cursor stays in the same column.

Note: If you hold **SHIFT** while pressing these keys, the cursor and/or letter moves in the reverse direction.

The closing paragraph of the sample letter contains one field. This paragraph begins on line 42 of the letter. Since this field is 10 characters long, 10 blank spaces are left for it.

Text Entries	Location	
	Line	Column
Your account representative,	42	15
10 SPACES for ACCOUNT REP field.	42	44
, would be pleased	42	54
to provide you with details. To schedule an appointment	43	15
with Dr. Alvord, call our offices at 1-800-555-4567.	44	15

A screen with these entries is shown on page 134.

During the design of your letter, the size of the fields to be included should be considered. Each field has a specific length. Date and autodate fields have a predefined length of eight characters, for example. This length does not include the field name or any indicators, just the length of the field itself. Computed fields have a length of 12.

Fields

Fields can be placed on letters to provide specific information from file records. FILE/80 has the capability to move text and fields on your letter so gaps don't appear in your letter when it is printed. When this capability is not used, fields take up the same amount of space as shown on the LETTER LAYOUT screen.

Note: Details on justification are provided under **Use of Justify Mode**, page 136.

To place a field on your letter, press **FIELD** on the LETTER LAYOUT screen. You can pick a field from the master form or enter an expression for a computed field. When **FIELD** is pressed, the FIELD SELECTION screen is displayed. To select the ACCOUNT REP field from the CLIENTS master form, position the cursor over the ACCOUNT REP field with **ENDLINE** and press **PICK**.

Press **PICK**

```

Form lines 16-33          ** FIELD SELECTION **          Format: MEMO
-----
COMPANY_#*# ████████████████████████████████████████
ADDRESS 1_#*# ████████████████████████████████████████
ADDRESS 2_#*# ████████████████████████████████████████
CITY/STATE_#*# ████████████████████████████████████████
ZIP CODE#*#*#NNNNN
ACCOUNT REP_#*# ████████████████████████████████████████
HOURS LOGGED_#*#*# ███████ MONTHLY
LAST CONTACTED_#*#*# █████/██/██
1 █ PICK █ 2 █ COMPUTED █ 3 █ _____ █ 4 █ _____ █ 5 █ _____ █ 6 █ REPT █ 7 █ _____ █

```

Note: Instructions for using the **COMPUTED** key for entering the expression of a computed field are provided under **Computed Fields** on page 101.

After **PICK** is pressed, the **PUT FIELD** screen is displayed. Use the cursor keys to place the field in the desired location. This screen shows that the **ACCOUNT REP** field has been placed on line 42, column 44 of the **MEMO** output format. The text on either side of the field was entered earlier in this section. When the field is in the desired location, press **PUT**.

Press **PUT**

```

Field: ACCOUNT REP          ** PUT FIELD **          Format: MEMO
                          Line 42 Column 44
-----
Your account representative, [REDACTED], would be pleased
to provide you with details. To schedule an appointment
with Dr. Alvord, call our offices at 1-800-555-4567.

1 F T 2 _____ 3 _____ 4 _____ 5 _____ 6 REPORT 7 _____

```

FILE/80 Display

After you press **PUT**, FILE/80 displays the **LETTER LAYOUT** screen. Additional fields or text can be added to your letter. This screen shows the field and text entries listed at the end of this section have been placed on the letter. When all fields and text have been placed on your letter, press **ACCEPT**:

Press **ACCEPT**

** LETTER LAYOUT **

Format: **MEMO**Line **48** Column **85**

Our firm is pleased to be able to offer the consulting area of Solar Engineering to our already broad range of services. Dr. David Alvord, a recent graduate of the Solar Engineering program of the University of Hawaii has recently joined the staff of CHANEY, MANN, and HILL. We know that you can benefit from the services of Dr. Alvord in any new or existing projects that you consider integrating with solar power.

Your account representative, [REDACTED], would be pleased to provide you with details. To schedule an appointment with Dr. Alvord, call our offices at 1-800-555-4567.

Cordially,

Bill Chaney

1. FILE 2. [REDACTED] 3. DATE 4. DELETE 5. MOVE 6. REDEF 7. ACCEPT

FILE/80 Display

When **ACCEPT** is pressed, the **LETTER FORMAT** screen is displayed. If you wish to make changes to your letter, you can press **LAYOUT** to display the **LETTER LAYOUT** screen again.

Moving Fields

To move a field follow these steps:

- a. The **LETTER LAYOUT** screen should be on your display. To display this screen, you can press **LAYOUT** on the **LETTER FORMAT** screen.
- b. Press **MOVE**. **FILE/80** displays the **MOVE FIELD** screen.
- c. Place the cursor over the field you wish to move. You can press **END LINE** or **SHIFT END LINE** to move the cursor.
- d. Press **PICK**.
- e. The **PUT FIELD** screen is displayed. You can move the field by pressing the cursor keys.
- f. Press **PUT**. Any text under the field is erased.

Note: If you press **PICK** accidentally, then press **PUT** immediately. The field will stay in the same location.

Deleting Fields

To delete a field follow these steps:

- a. The LETTER LAYOUT screen must be on your display.
- b. Press **DELETE**. FILE/80 displays the DELETE FIELD screen.
- c. Move the cursor over the field you wish to remove. To move the cursor, press **END LINE** or **SHIFT** **END LINE**.
- d. Press **PICK**.

Note: If you press **DELETE** accidentally, press **ABORT** on the DELETE FIELD screen. No fields will be removed from your letter.

Use of Justify Mode

Justify mode eliminates blank spaces in fields on your letters by moving fields and text to the left. At least one space must be left between fields on a line for justification to occur. Leading and/or trailing blanks are removed from all fields. The justify mode makes all your letters appear as if they were individually prepared because no blank spaces appear around fields unless you put them there.

Note: Text and fields are not moved from line to line, only towards the left in the same line.

When justify mode is used, lines with no text are removed from your letter if they only contain fields that are completely blank. This is useful for foreign addresses with a variable number of lines, for instance. On the sample letter shown in the overview, the line containing the ADDRESS 2 field doesn't appear in printed letters when the ADDRESS 2 field only contains blanks for the letter being printed.

Here is the data used to print the letter:

Field	File Record Data
COMPANY	Robinson-Douglas Inc. _____
ADDRESS 1	51 Marsh Boulevard _____
ADDRESS 2	_____
CITY/STATE	Boston, Massachusetts _____

This is the arrangement of fields on the letter:

COMPANY	████████████████████
ADDRESS 1	████████████████████
ADDRESS 2	████████████████████
CITY/STATE	████████████████████

FILE/80 gives you the choice of justifying your letters or leaving them just as you enter them by changing the `Justify` setting on the `DEFAULTS` screen. Justification is originally set to `YES`, so if you want your letters justified you don't have to change it. If you change the `Justify` setting to `NO` then no justification is performed.

If no justification was performed with the sample letter, then the closing paragraph would look like this:

Your account representative, Mr. East , would be pleased to provide you with details. To schedule an appointment with Dr. Alvord, call our offices at 1-800-555-4567.

Trailing blanks are present because the length of the field is 10 characters and the account representative's name, Mr. East, only contains eight characters.

Ordering Letters

FILE/80 prints letters defined with letter output formats in the order you specify with the `SORTED LETTER` screen. A blank master form is displayed in the information window of the `SORTED LETTER` screen. By pressing the special function keys `ASCEND` and `DESCEND` you can select the printing order. To specify a printing order for your letters, you press `SORT` on the `LETTER FORMAT` screen.

Note: If no printing order is specified, FILE/80 prints your letters in primary key order.

Press **SORT**

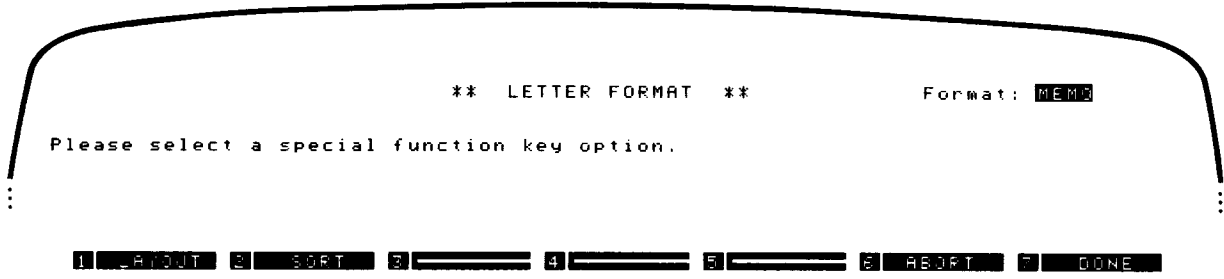

FILE/80 Display

After you press **SORT**, FILE/80 displays this screen. You move the cursor over the field you wish to order your letters by and press either **ASCEND** or **DESCEND**. To designate the ZIP CODE field as an ascending sort field, press **ENDLINE** several times to move the cursor over it. Then press **ASCEND**. When all sort fields have been specified, press **ACCEPT**.

Press **ASCEND ACCEPT**

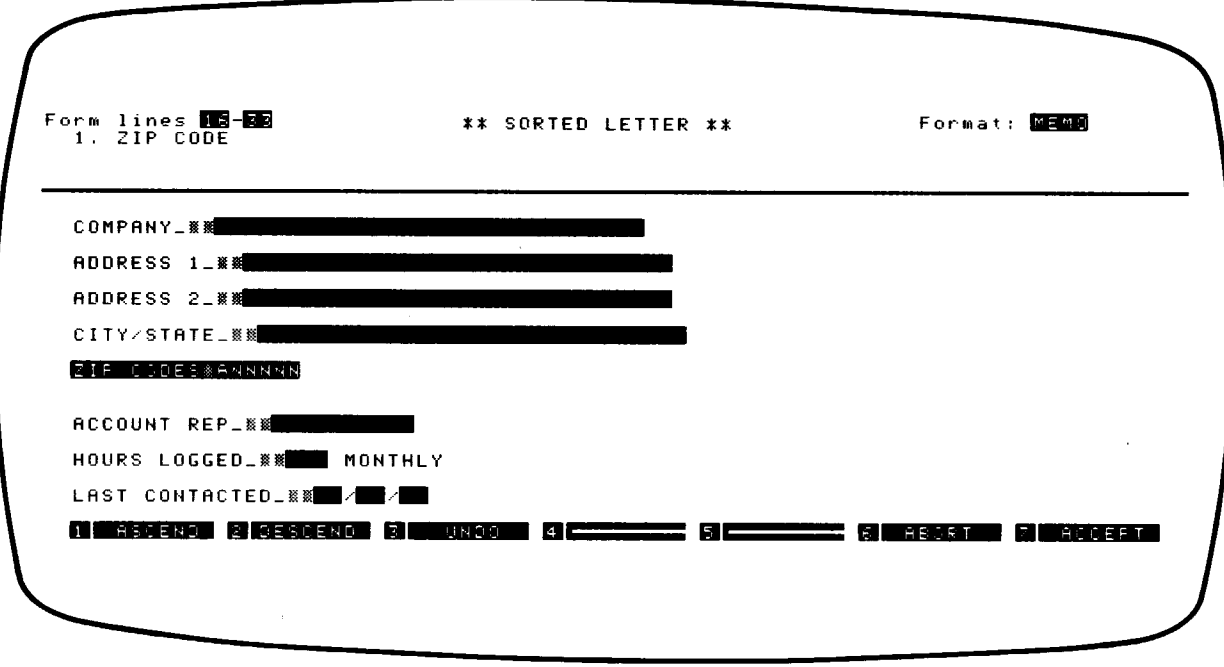

FILE/80 Display

Note: Additional information on choosing sort fields is provided under **Ordering Your Report**, on page 107.

After you press **ACCEPT**, the **LETTER FORMAT** screen is displayed. You can press **DONE** if you are finished entering text and fields for your letter. When **DONE** is pressed, your output format is stored on disc and the **PRINT SPECIFICATIONS** screen is displayed for printing letters.

Printing Letters

The **PRINT SPECIFICATIONS** and **LETTER** screens are used for printing letters. The **PRINT SPECIFICATIONS** screen is displayed when you press **DONE** on the **LETTER FORMAT** screen. When you press **PRINT** on the **PRINT SPECIFICATIONS** screen, the **SORT** screen is displayed if sorting is necessary for your letters. Otherwise, the **LETTER** screen is displayed.

It is important to turn on your printer before pressing **RUN** when loading **FILE/80**. If you turn on your printer while **FILE/80** is running, you risk *damaging your files*. You can use the utilities covered in sections 9 and 10 of this manual for restoring your files. When recent backup copies aren't available, restoring your files can be very time-consuming and in some cases only part of a damaged file can be restored.

```

** PRINT SPECIFICATIONS **           Format: MEMO
Please select a special function key.
:                                     :
1 EDIT  2 DEFAULTS  3 SEARCH  4 _____  5 _____  6 ADAPT  7 PRINT

```

FILE/80 Display

The **PRINT SPECIFICATIONS** screen enables you to specify conditions for the letters you wish to print. These special function keys are provided:

EDIT Press this key to display the **LETTER FORMAT** screen. Your output format can be changed. Refer to **Changing Reports**, page 122, for details.

DEFAULTS Press this key to change defaults like the Printer address or Form size (Lines).

SEARCH Press this key to select records for printing letters. The conditions you enter remain in effect from one session to the next. If you don't specify search conditions, one letter is printed for each record in your file. Refer to the **SEARCH Screen Summary** on page 86 for details.

ABORT Press this key to display the **OUTPUT** screen.

PRINT Press this key to start the printing of your letters. The **SORT** screen is displayed if sorting is necessary. Otherwise, the **LETTER** screen is displayed.

Defaults

Before printing your letters, you should check the **DEFAULTS** screen to verify the proper defaults have been set. When you press **DEFAULTS**, this screen is displayed.

```

** DEFAULTS **                               Format: MEMO
-----
Please select the defaults you wish to CHANGE.
-----
1. Printer address: 701
2. Printer type: 1
3. Number of copies: 1
4. Stop between pages: NO
5. Form size (Lines): 66
6. Justify: YES
7. Reuse sorted list: NO

1 CHANGE 2 _____ 3 _____ 4 _____ 5 _____ 6 _____ 7 ACCEPT

```

FILE/80 Display

To change a default, you move the cursor to the number beside the default and press **CHANGE**. The cursor can be moved by pressing **END LINE** or **SHIFT END LINE**. When you press **CHANGE**, a prompt is displayed in the title/feedback window. You enter the new setting and press **END LINE**. When all defaults are correct, press **ACCEPT**. The following default settings are possible:

Printer address: FILE/80 originally sets this default to 701.

Printer type: Refer to appendix C.

Number of copies: 1 through 99 copies are permitted. FILE/80 originally sets this default to 1.

Stop between pages: YES, NO. FILE/80 originally sets this default to NO. If this item is set to YES, then you must press **CONTINUE** to resume printing after each page is produced. This allows you to print letters on non-continuous forms.

Form size (Lines): 1 to 99 are permitted. FILE/80 originally sets this default to 66. This item should be set to the size of the paper forms being used in your printer.

Justify: YES, NO. The default setting is YES. FILE/80 will eliminate leading and trailing blank spaces in fields placed on your letter when this is set to YES. Refer to **Use of Justify Mode**, page 136, for details.

Reuse sorted list: YES, NO. The default setting is NO. If you change this item to YES, no sorting is performed. Instead, the order of records is determined by a sorted list of records used for a previous output format. Any current sort fields or search conditions are disregarded.

You must set this item to YES each time you want to use the sorted list. When you change this item to YES, a message is displayed giving the number of additions, updates, and deletions in your file since the sorted list was generated. If a valid sorted list doesn't exist for your file, then the Reuse sorted list default is not present.

The sorted list is generated whenever the default setting is NO and the output format being printed has at least one sort field. Depending on the sort field(s), the sorted list can be generated at two different times:

- A sorted list is generated when the SORT screen is displayed after pressing **PRINT**.
- If the SORT screen is not displayed after pressing **PRINT**, a sorted list is generated during initial printing while the LETTER screen is displayed.

Note: If **ABORT** is pressed on either the SORT or LETTER screens while the sorted list is being generated, the list becomes invalid.

The LETTER Screen

When you press **PRINT** on the PRINT SPECIFICATIONS screen, the printing of your letters starts. (The SORT screen is displayed first if sorting is necessary.) When printing begins, the LETTER screen is displayed. A counter on the LETTER screen indicates which letter is being printed. As each letter is printed, it is also displayed on the LETTER screen. When printing begins, this screen is displayed:

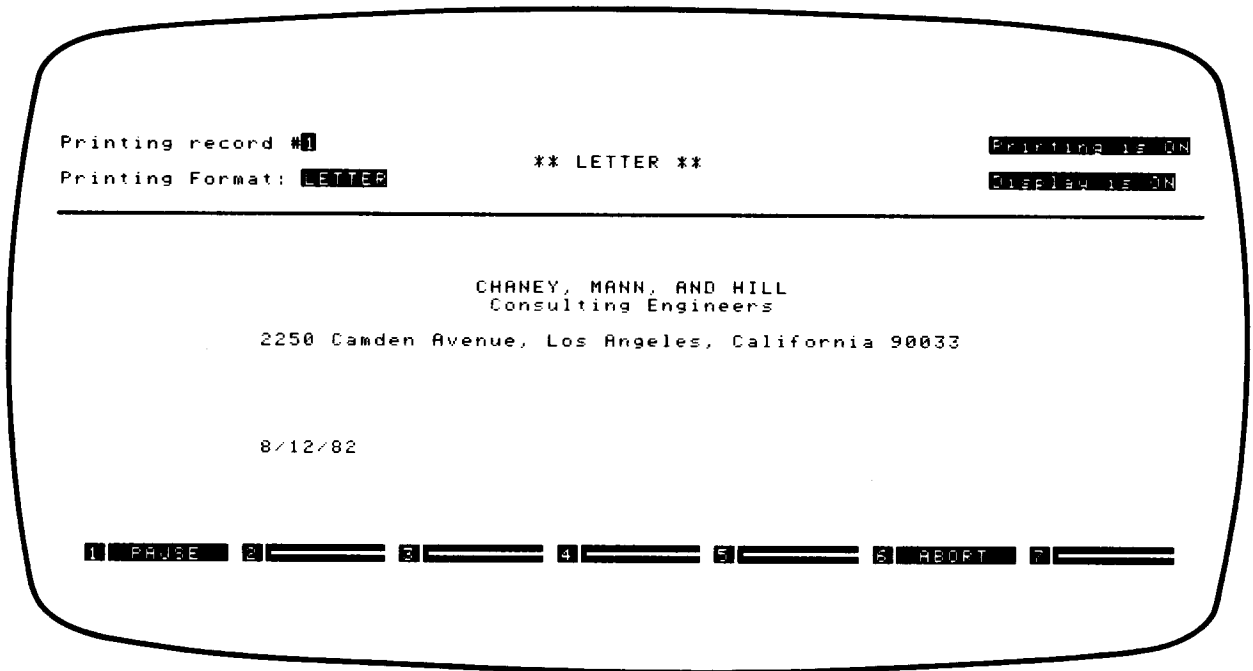

FILE/80 Display

These keys are displayed when **ABORT** is pressed or after all letters are printed:

CONTINUE Press this key to continue printing letters.

EDIT Press this key to edit the letter format. Instructions are provided under **Changing Reports** on page 122.

SPICE Press this key to display the PRINT SPECIFICATIONS screen.

OUTPUT Press this key to access other output formats.

EXIT Press this key to end the session and return your HP-86/87 to calculator mode.

If you press **PAUSE**, this screen is displayed:

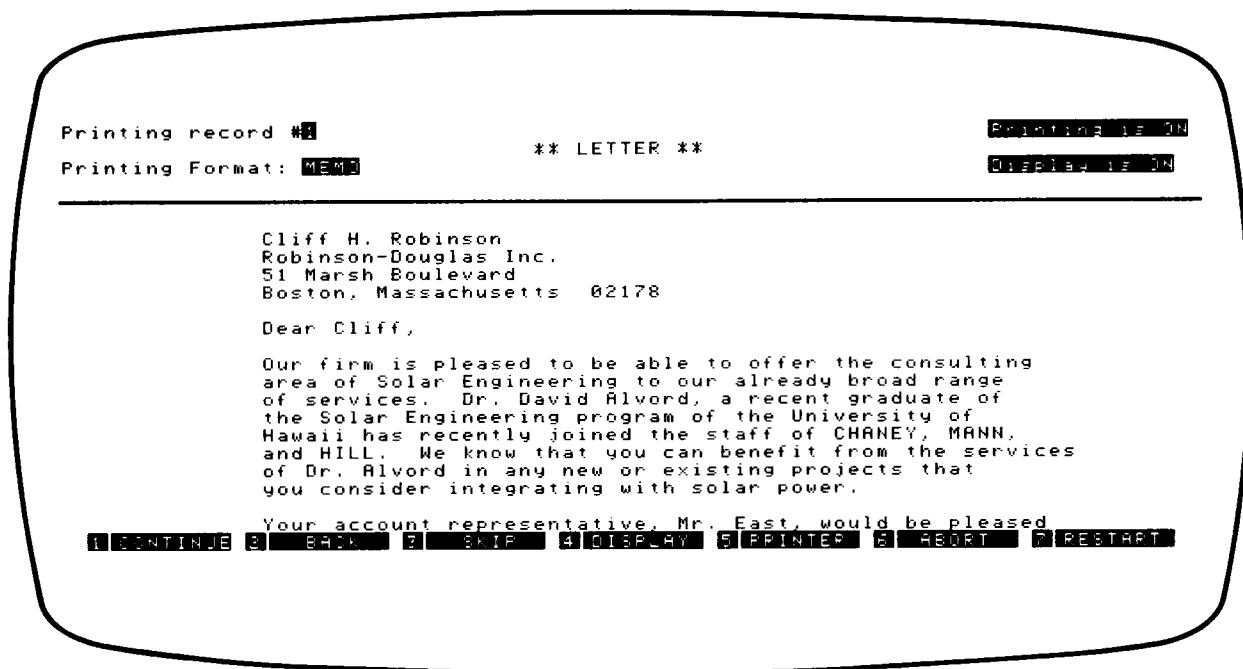

FILE/80 Display

The special function keys can be used as follows:

CONTINUE Press this key to resume the printing of your letters with the next line. If the record counter has been changed, the printing starts with the letter specified by the counter.

BACK Press this key to decrement the record counter. This key allows you to make additional copies of specific letters.

SKIP Press this key to increment the record counter. This allows specific letters to be skipped.

DISPLAY Press this key to change the **DISPLAY IS ON/OFF** setting on the **LETTER** screen. This determines whether or not letters are displayed on the **LETTER** screen.

PRINTER Press this key to change the **PRINTER IS ON/OFF** setting on the **LETTER** screen. This determines whether or not your HP-86/87 sends information to your printer.

Note: You cannot turn both the display and printer to **OFF**.

ABORT Press this key to display the keys described following the LETTER screen on page 143.

RESTART Press this key to print letters over again starting with the first letter.

CLIENTS File Output Format: LETTER**Fields**

These fields can be added to a letter using the LETTER LAYOUT screen. The location of each field is indicated by the line and column counters.

	Line	Col.
Date field obtained by pressing DATE	21	15
FIRST NAME	25	15
MIDDLE INITIAL	25	31
LAST NAME	25	34
COMPANY	26	15
ADDRESS 1	27	15
ADDRESS 2	28	15
CITY/STATE	29	15
ZIP CODE	29	47
FIRST NAME	31	20
ACCOUNT REP	42	44

Text Entries

CHANEY, MANN, AND HILL	12	30
Consulting Engineers	13	31
2250 Camden Avenue, Los Angeles, California 90033	15	15
.	25	32
Dear	31	15
,	31	35
Our firm is pleased to be able to offer the	33	15
consulting		
area of Solar Engineering to our already broad range	34	15
of services. Dr. David Alvord, a recent graduate of	35	15
the Solar Engineering program of the University of	36	15
Hawaii has recently joined the staff of CHANEY, MANN,	37	15
and HILL. We know that you can benefit from the	38	15
services		
of Dr. Alvord in any new or existing projects that	39	15
you consider integrating with solar power.	40	15
Your account representative,	42	15
, would be pleased	42	54
to provide you with details. To schedule an	43	15
appointment		
with Dr. Alvord, call our offices at 1-800-555-4567.	44	15
Cordially,	46	15
Bill Chaney, President	49	15

Sort Fields

ZIP CODE **HSCINL**

Defaults

These settings are entered on the DEFAULTS screen after pressing **DONE** on the LETTER FORMAT screen. When the PRINT SPECIFICATIONS screen is displayed, you can press **DEFAULTS** to display these items:

Printer address Set this item to the address of your printer.

Printer type Refer to appendix C.

Number of copies: 1

Stop between pages: NO

Form size (Lines): 66 If you are using non-standard forms, this item should be changed to the maximum number of lines that can be printed on a page.

Justify: YES

Reuse sorted list: NO

Search Conditions

These conditions are entered after pressing **DONE** on the LETTER FORMAT screen. When the PRINT SPECIFICATIONS screen is displayed, press **SEARCH**. When the SEARCH screen is displayed, move the cursor over the LAST CONTACTED field.

Enter the date 06/30/82 and press **RELATION**. Next, press **>**. Since this is the only search condition, you can press **ACCEPT**. The PRINT SPECIFICATIONS screen is displayed. When letters are printed, only those records with a date later than 06/30/82 in the LAST CONTACTED field will be accessed.

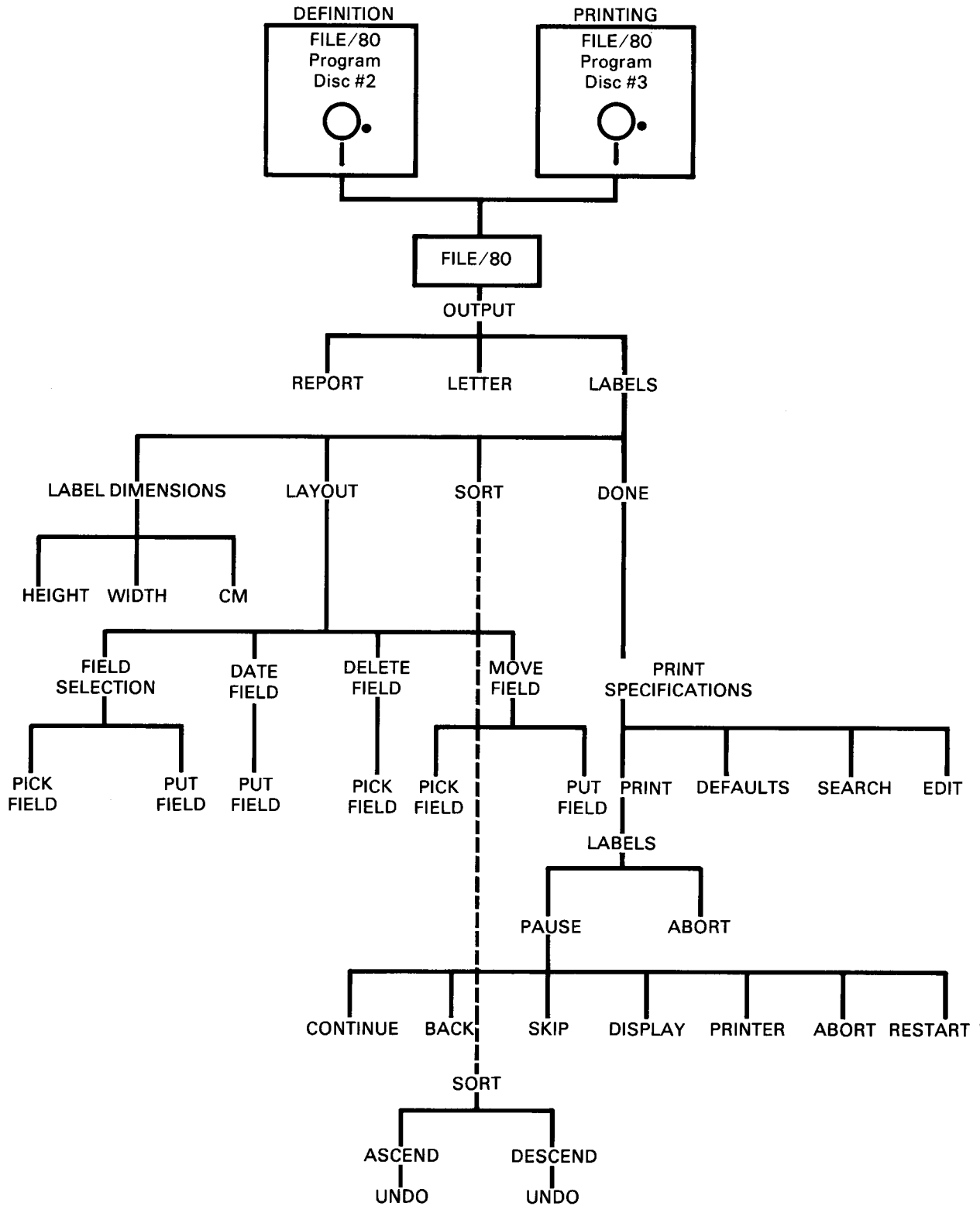

LABELS Diagram

Printing Labels

In this section, examples show you how to define and print the sample labels shown in the overview. You will need the following:

- FILE/80 Program Disc #2
- FILE/80 Program Disc #3
- FILE/80 Demonstration Disc

Introduction

To complement your letters, FILE/80 provides you with a simple and easy to use format for printing labels. Labels are designed on the screen of your HP-86/87. Whether you're trying to reach a particular group of clients with letters, mailing packages, or managing an inventory, you'll find the label output formats possible with FILE/80 a convenient answer to your needs.

The use of labels can help you perform a variety of reporting tasks in a more efficient and timely fashion. When information on a new client is added to your file, for instance, new labels for mailing or identification purposes can be printed instantly. When you update a record in your file, the new information reaches your clients—accurately. This is because the same information is used to produce your reports, letters, and mailing labels.

The label output formats of FILE/80 are easy to change. Choosing new fields for a label is handled the same way as in the original label design. In addition, the printing order of labels can be easily changed.

Use of FILE/80 Program Discs

It is only necessary to have one FILE/80 Program Disc on-line at a time. When you are defining a label output format, use FILE/80 Program Disc #2. When you are printing a label output format, use FILE/80 Program Disc #3. However, you can load FILE/80 from any of the four Program Discs. When a disc is needed that isn't on-line, a message instructs you to insert it.

Label Size

Before entering text or selecting fields to define the appearance of your label, you key in the dimensions (inches or centimeters) of the labels you're planning to use. To enter the dimensions in centimeters, press **cm**. Most label suppliers print these dimensions on the label package. If you are entering dimensions in inches, round the label height to the nearest half-inch. For example, if your labels are $1\frac{1}{16}$ inches high and 4 inches wide, then you would enter the dimensions 1.5 by 4 inches. The screens and keystrokes in this section describe how to specify a 1.5 by 4 inch label. FILE/80 supports label heights from 0.5 to 3 inches and label widths from 2 to 5 inches. In centimeters, these limits are 1.3 to 7.6 for the height and 5 to 12.7 for the width.

Note: To insure the printing of all text and field entries on the label surface, it is recommended that no entries be made in lines or columns adjacent to the edges of labels. With 4-inch wide labels, data in the rightmost column of the print-line can be truncated if the **Labels across** setting is 2.

The following steps are required before defining a label:

- Load the program from FILE/80 Program Disc #2. The disc(s) containing the file you are defining the output format for must be on-line. In addition, disc space for storing the label output format you'll define must also be available. The file for which a label is defined must be on-line. To define the sample label shown in the overview, use the FILE/80 Demonstration Disc. This disc can also be used for storing formats. After pressing **(RUN)**, press **OLD FMT**.
- Enter the file name and password (optional). For the examples in this section, you should enter the file name **CLIENTS**. The password is **HP**. Verify the **MSUS** of each drive on-line when the **MSUS** table is displayed. When each **MSUS** in the table is complete and correct, press **ACCEPT**.

FILE/80 displays this screen. It is possible to make other changes to your file before defining the dimensions of a label. Whenever the following screen is on your display, you can press **OUTPUT** to access an old output format or define a new one.

Press **OUTPUT**

```

FILE NAME: CLIENTS          ** FILE/80 **          TODAY'S DATE: 08-12-88
Please select a special function key.

1 QUERY  2 OUTPUT  3 REDEFINE  4 TABS  5 DEFAULTS  6 EXIT  7 DONE

```

FILE/80 Display

Accessing Output Formats

Output format names are needed to identify disc files. The format name can contain any upper or lower case letters or digits and has a maximum length of eight characters. Whenever you enter the name of an output format, FILE/80 checks to see if a disc file beginning with that name and ending with the characters `_L` is on-line. If the disc file is present, FILE/80 displays the PRINT SPECIFICATIONS screen. Otherwise, the OUTPUT TYPE screen is displayed. You can press **ABORT** on either screen to re-enter the format name.

Defining Labels

Before printing labels, you define them with label output formats. Each output format contains your text entries, any fields you selected from the master form, and the printing order of the labels themselves. Each label format has its own name, just like the letter and report formats covered in sections 4 and 5. Enter MAILING for the name of the output format.

Press (M) (A) (I) (L) (I) (N) (G) (ENDLINE)

```

** OUTPUT **
FORMAT NAME? MAILING
1 DUMP ALL 2 _____ 3 _____ 4 _____ 5 _____ 6 ABORT 7 _____

```

FILE/80 Display

Since this name doesn't match any of the output formats already stored on-line, FILE/80 assumes you intend to define a new format and displays the OUTPUT TYPE screen. The special function keys of the OUTPUT screen can be used as follows:

DUMP ALL Press this key to produce a master form summary followed by copies of each record in your file. You can view these on the screen or print them. Instructions for using this key are provided under **Use of DUMP ALL** on page 94.

ABORT Press this key to display the FILE/80 screen.

To choose a label output format type, do the following:

Press **LABELS**

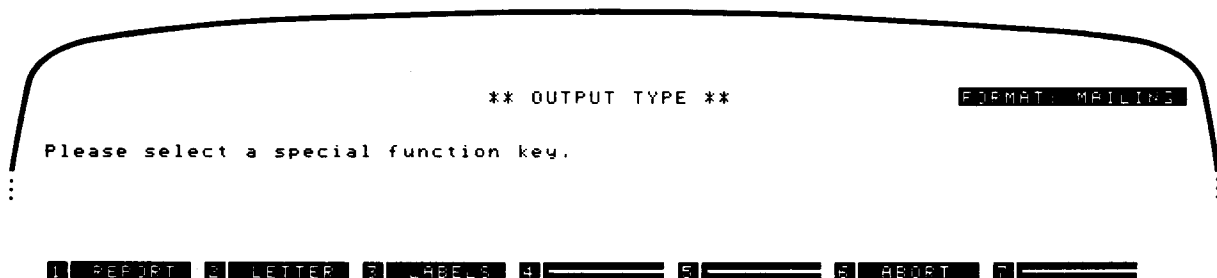

FILE/80 Display

Entering Dimensions

The default size for a label is Height: **1** inch and Width: **3.5** inches. To change these dimensions, you press the keys **HEIGHT** or **WIDTH** on this screen. To use the MAILING output format to print labels on 1 $\frac{1}{8}$ by 4-inch label stock, change the height of the label from 1.0 to 1.5 inches and the width of the label from 3.5 to 4.0 inches. The **BACKSPACE** key can be used to edit each entry before pressing **ENDLINE**.

Note: If you are using centimeters for label dimensions, press **cm.** before entering the height or width. When you press **cm.**, the default dimensions for centimeters are displayed. These are 3.8 for the height and 8.8 for the width. The **cm.** key now shows **in.**. If you press **in.**, the default dimensions for inches are displayed.

Press **HEIGHT** **1** **.** **5** **ENDLINE** **WIDTH** **4** **ENDLINE** **ACCEPT**

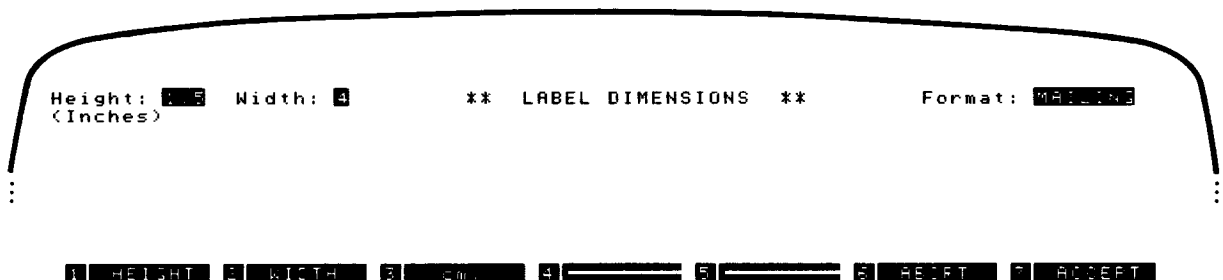

FILE/80 Display

When you press **↑**, FILE/80 displays the LABEL FORMAT screen.

Converting Dimensions

FILE/80 uses the height and width dimensions you enter to draw a label on the information window of the LABEL LAYOUT screen. The number of lines and columns on the label match the dimensions just entered. The following conversion factors are used:

Height: For each inch you enter in label height, FILE/80 places six lines on your label. This means labels between 3 and 18 lines can be printed since the limits on label height are ½ and 3 inches, respectively.

Width: FILE/80 uses 10 columns for each inch of your label. The column width of your label can range from 20 to 50 columns.

For example, if a label output format is defined for a height of 1.0 inches and a width of 3.5 inches, then the converted dimensions are 6 lines by 35 columns.

Label Layout

The format of a label is entered in a box drawn by FILE/80 on the LABEL LAYOUT screen. The dimensions of the box are adjusted so the number of characters you can enter corresponds to the dimensions that were entered on the LABEL DIMENSIONS screen. When **↑** is pressed, the LABEL FORMAT screen is displayed. To specify the appearance of a label, press **↓**:

Press **↓**

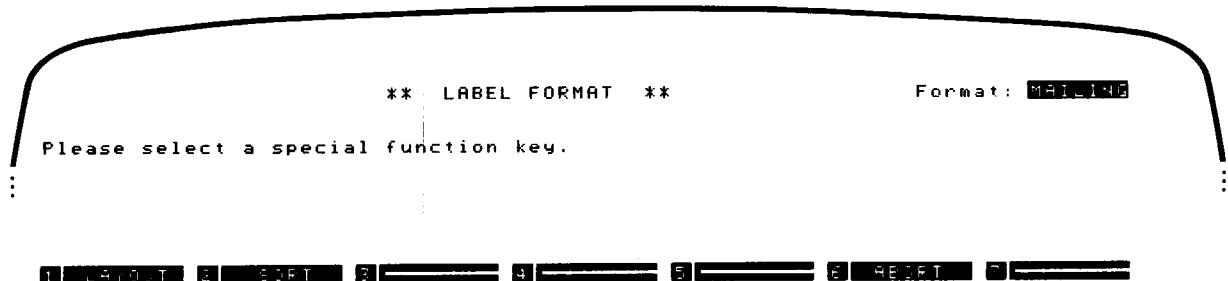

The following special function keys are provided:

LAYOUT Press this key to specify the appearance of the label with text entries and fields.

SORT Press this key to choose the printing order for your labels.

ABORT Press this key to clear the output format and display the LABEL DIMENSIONS screen.

Text

The LABEL LAYOUT screen is used to specify the appearance of your label and enter text. The cursor cannot be moved outside the boundaries of the label on the screen. You can use the (SPACE BAR), (BACK SPACE), and cursor keys to position the cursor on the label. Text can be placed anywhere on the label from the keyboard of your computer.

If you choose to sort your labels by zip code, you might want to indicate this by having them printed with the following text. Before entering the following keystrokes, position the cursor on line 2, column 26 of the label on your screen.

Press (P)(R)(E)-(S)(O)(R)(T)(E)(D)

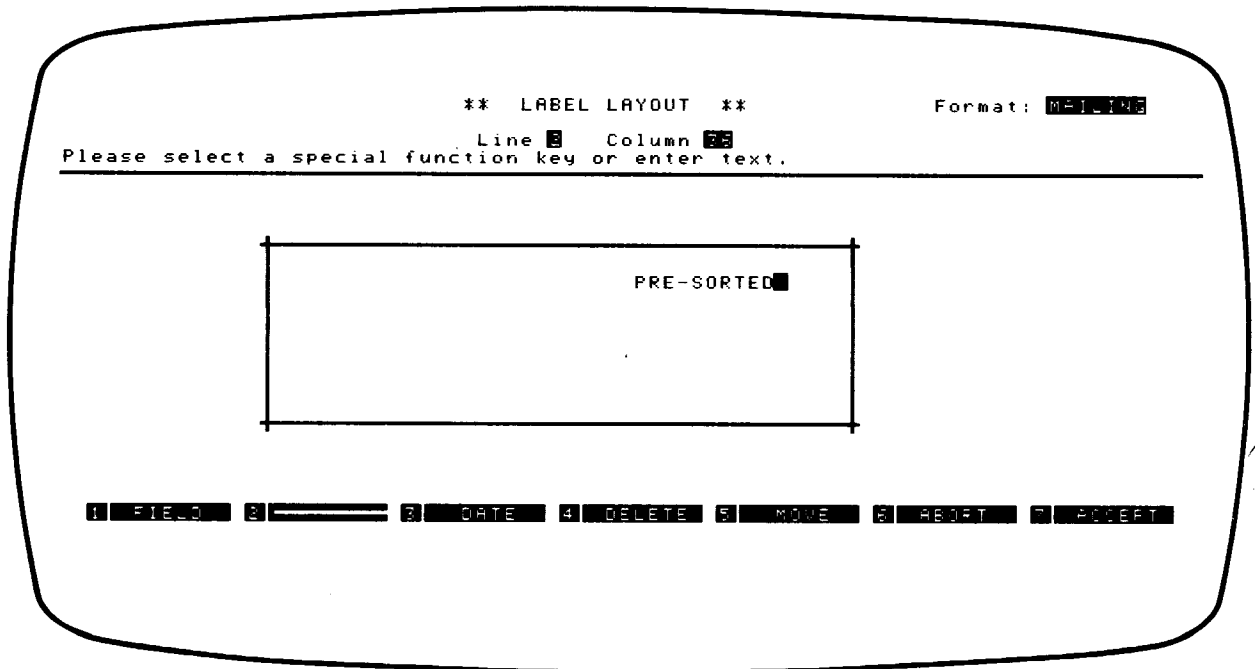

The following special function keys can be used:

FIELD Press this key to add fields to your label from the master form.

DATE Press this key to place a date field on your label.

DELETE Press this key to remove fields from your label.

MOVE Press this key to move fields already on your label.

ABORT Press this key to clear your label.

ACCEPT Press this key when you are finished entering fields and text on your label. The LABEL FORMAT screen is displayed.

Fields

To select fields from your master form, press **FIELD** on the LABEL LAYOUT screen. FILE/80 displays the FIELD SELECTION screen with the master form in the information window. Up to 100 fields can be placed on a label. Note that the choice of character fields is limited by label width. To select a field, move the cursor over the field you wish to select and press **PICK**.

For example, the FIRST NAME field from the CLIENTS master form can be selected. Move the cursor over the FIRST NAME field by pressing **END LINE** several times and then press **PICK**. If you move past this field, hold **SHIFT** down and press **END LINE** to move the cursor in the reverse direction.

Press **PICK**

```

Form lines 1-18          ** FIELD SELECTION **          Format: MAILING
-----
ACCOUNT_###-###-####          CHANEY, MANN, AND HILL          PHONE_###(###) ###-####
                               Consulting Engineers
                               CLIENT QUICK REFERENCE FILE

LAST MODIFIED ON_###/##/##
LAST NAME_#####
FIRST NAME_###
MIDDLE INITIAL_###
COMPANY_#####
1 PICK 2 _____ 3 _____ 4 _____ 5 _____ 6 ABORT 7 _____

```

Next, FILE/80 displays the PUT FIELD screen. The text you entered earlier is still present on the label. Move the FIRST NAME field with the cursor keys to line 4, column 6. The line and column counters indicate the position of the leftmost character in the field you are moving.

Press **PUT**

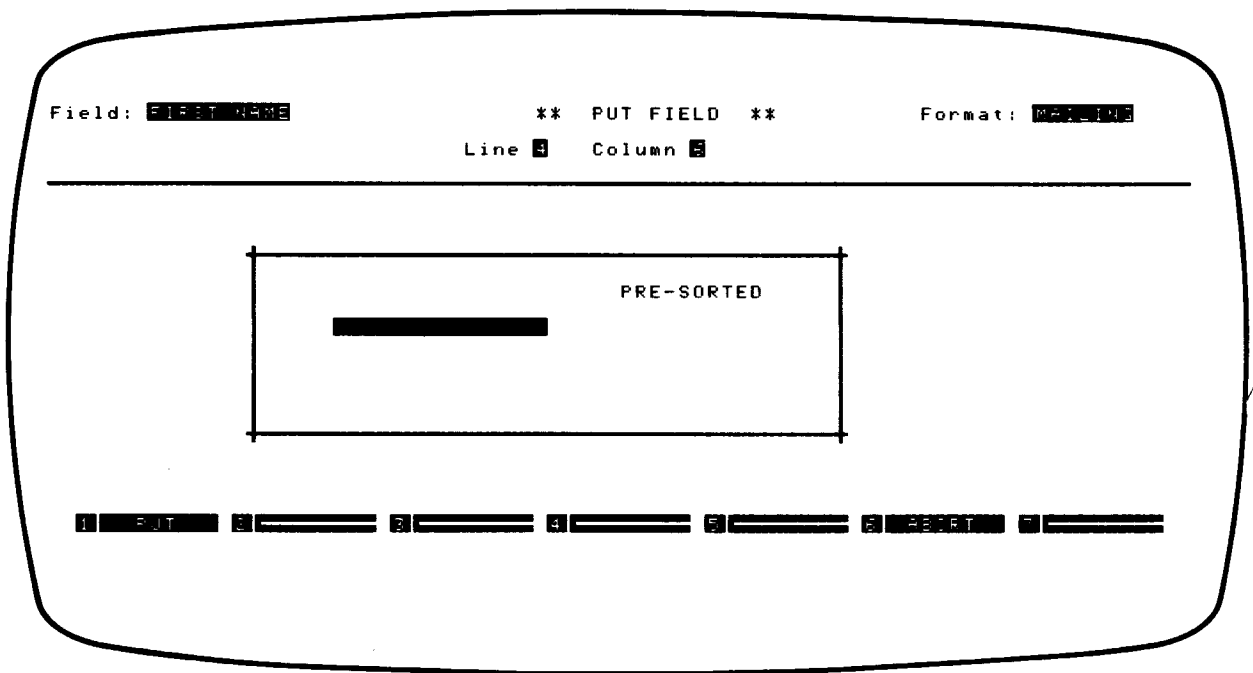

FILE/80 Display

When **PUT** is pressed, FILE/80 displays the LABEL LAYOUT screen. Any text or fields currently on the label are displayed. If you press **PUT** when the field is over another field already on the label, a message is displayed. You cannot place one field over another. If you press **PUT** when the field is over text on the label, the text is removed.

After specifying the appearance of a label by entering fields and text on the LABEL LAYOUT screen, you can press **ACCP**.

Press **ACCEPT**

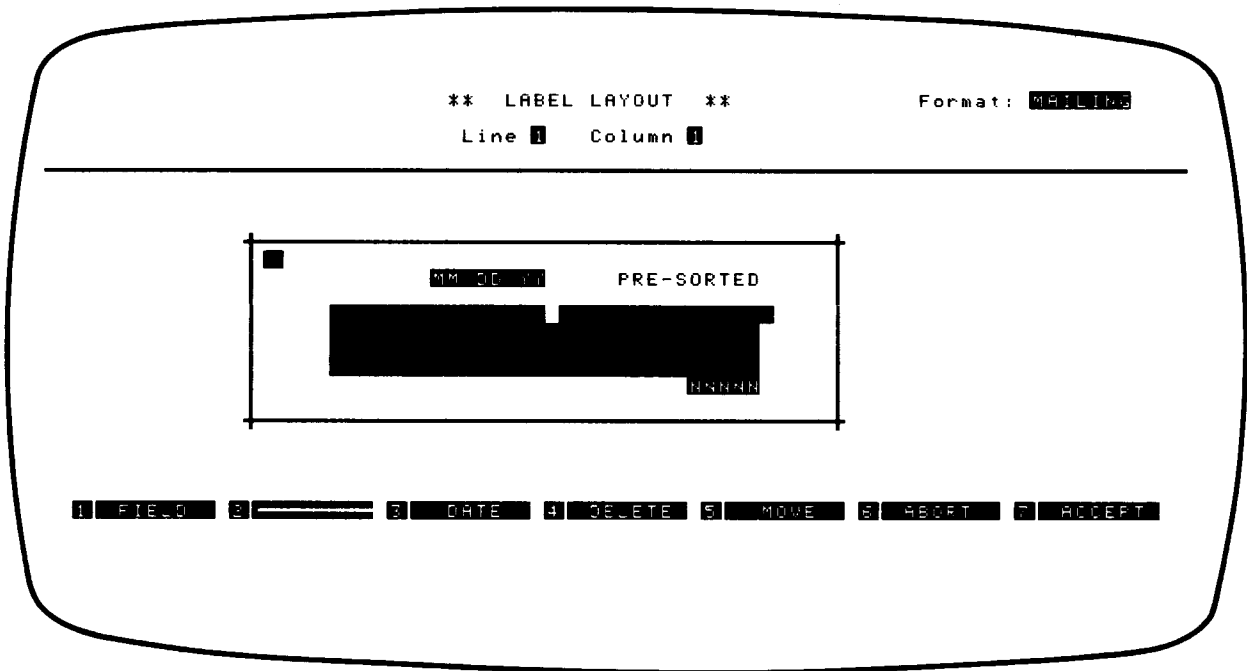

FILE/80 Display

Note: Additional fields and text shown on this screen are listed at the end of this section.

After you press **ACCEPT**, FILE/80 displays the LABEL FORMAT screen. This screen has the **LAYOUT**, **SORT**, **ABORT**, and **DONE** special function keys.

You can make changes to your label by pressing **LAYOUT**. The label is presented just as you left it when **ACCEPT** was pressed on the LABEL LAYOUT screen. The following instructions tell you how to add a date field. Besides adding fields, you can move a field, delete a field, or change text entries.

How to Date Your Labels

Follow these steps to place a date field on your label:

- a. If the LABEL LAYOUT screen *isn't* on your display, press **LAYOUT** on the LABEL FORMAT screen to display it.
- b. Press **DONE** on the LABEL LAYOUT screen. FILE/80 displays the PUT FIELD screen with the date field on your label. When labels are printed, FILE/80 enters the current date. This is the date entered at the beginning of the session when printing occurs. All labels printed during a given session have this date.

- c. Use the cursor keys to move the date field to the desired location. When the field is in the right location, press **PUT**. The date field cannot be placed over fields already on the label. Press **ACCEPT**. FILE/80 displays the LABEL LAYOUT screen with the modified label.

How to Specify Printing Order

Follow these steps to designate sort fields:

- a. Press **SORT** on the LABEL FORMAT screen.
- b. FILE/80 displays the SORTED LABEL screen.
- c. Designate the sort fields by moving the cursor over the fields of your choice and pressing **ASCEND** or **DESCEND**. For example, to print your labels by zip code, press **END LINE** several times to position the cursor over the ZIP CODE field. Press **ASCEND**.
- d. Press **ACCEPT** on the SORTED LABEL screen.

Note: For additional information, refer to **Ordering Your Report** on page 107.

Justified Labels

FILE/80 automatically justifies fields on your labels so gaps don't appear when fields on a label contain blanks. If you want fields and text to appear exactly where you entered them, change the **Justify** setting on the DEFAULTS screen to **NO**.

When justification occurs, text and fields are moved to the left one space for each leading or trailing blank in fields on the same line. The spacing between fields and text entries on the line is preserved. You must leave one space between fields for justification to occur on a line.

When a line contains no text and one or more fields, justification can occur between lines. For this to occur, all fields on the line must be blank. These blank lines are not printed. Any remaining lines on the label are moved up a line.

For more information, refer to **Use of Justify Mode** on page 136.

Storing Label Output Formats

Before any labels can be printed, it is necessary to store your output format on disc. To store a format, press **DONE** on the LABEL FORMAT screen. Your format is stored on the first disc with sufficient space. After **DONE** is pressed, the PRINT SPECIFICATIONS screen is displayed.

Printing Your Labels

The **PRINT SPECIFICATIONS** screen is used for printing labels. You can display this screen by pressing **DOWN** on the **LABEL FORMAT** screen or entering the name of an output format on the **OUTPUT** screen that is already on-line. **FILE/80** allows you to choose what records are used for printing your labels with the **SEARCH** special function key. Printing of your labels begins when the **PRINT** special function key is pressed.

Once printing has started, the **LABELS** screen is displayed on your HP-86/87. If you press **PAUSE**, printing is interrupted and a new special function window is displayed. This window includes the keys **BACK** and **SKIP** that enable you to move backwards or forwards through the records selected for printing. You can easily obtain multiple copies of one label or skip unwanted records in your file.

Changes in the placement of text and fields on labels must be made to the output format itself. Instructions at the end of this section explain how to change text entries and move or delete fields already placed on a label.

Setting Defaults

Before printing your labels, it is recommended that you check the **DEFAULTS** screen. You can leave the defaults the same or change them. To display this screen, press **DEFAULTS** on the **PRINT SPECIFICATIONS** screen.

```

** DEFAULTS **                               Format: MAILING
Please select the defaults you wish to CHANGE.
-----
1. Printer address: P01
2. Printer type: 1
3. Number of copies: 1
4. Labels across: 1
5. Justify: YES
6. Reuse sorted list: NO

1 CHANGE 2 _____ 3 _____ 4 _____ 5 _____ 6 _____ 7 ACCEPT

```

Check the list of defaults on your screen. Be sure the printer address and type are correct. To change any defaults, move the cursor to the number beside the item you wish to change and press **CHANGE**. You can press **END LINE** or **(SHIFT) END LINE** to move the cursor. When you press **CHANGE**, a message appears in the title/feedback window. Make the correct entry. When the list is correct, press **ACCEPT**.

The original default settings remain in effect until you change them. When you access the output format again, default settings remain unchanged from when **ACCEPT** was last pressed on the **DEFAULTS** screen. The following default settings are possible for label output formats:

Printer address: The default setting is 701.

Printer type: Refer to appendix C.

Number of copies: 1 through 99 are permitted. The default setting is 1.

Labels across: 1 through 4 are permitted. The default setting is 1. This default refers to the number of labels across a page. If you are using a single roll of labels, use the original default setting of 1.

Justify: YES, NO. The default setting is YES. Refer to **Justified Labels**, page 158, for details.

Reuse sorted list: YES, NO. The default setting is NO. If you change this item to YES, no sorting is performed. Instead, the order of records is determined by a sorted list of records used for a previous output format. Any current sort fields or search conditions are disregarded.

You must set this item to YES each time you want to use the sorted list. When you change this item to YES, a message is displayed giving the number of additions, updates, and deletions in your file since the sorted list was generated. If a valid sorted list doesn't exist for your file, then the **Reuse sorted list** default is not present.

The sorted list is generated whenever the default setting is NO and the output format being printed has at least one sort field. Depending on the sort field(s), the sorted list can be generated in two different ways:

- A sorted list is generated when the **SORT** screen is displayed after pressing **PRINT**.
- If the **SORT** screen is not displayed after pressing **PRINT**, a sorted list is generated during the initial printing while the **LABELS** screen is displayed.

Note: If **ABORT** is pressed on either the **SORT** or **LABELS** screens while a sorted list is being generated, the list becomes invalid.

Choosing Records

To choose which records are accessed to print your labels, you can press the **SEARCH** special function key on the **PRINT SPECIFICATIONS** screen. The conditions you enter on the **SEARCH** screen determine which records are accessed to print labels. You can refer to the **SEARCH Screen Summary** on page 86 for details. The conditions you enter on the **SEARCH** screen are "remembered" from one session to the next.

How to Print Labels

Turn on your printer before loading the **FILE/80** program. If you turn your printer on while the **FILE/80** program is running, your files can be damaged. Instructions for recovering these files are provided in sections 9 and 10 of this manual. In some cases, only part of a file can be recovered.

Press **PRINT** on the **PRINT SPECIFICATIONS** screen to start printing labels. The **LABELS** screen is then displayed. When you specify a printing order with the **SORTED LABEL** screen and sorting is necessary, pressing **PRINT** displays the **SORT** screen. If sorting is not necessary, printing begins as soon as you press **PRINT**.

Printing label # 2

Format: LABEL

** LABELS **

PRINTING IS ON

DISPLAY IS ON

MAILED 8/12/82 PRE-SORTED

Cliff Robinson
51 Marsh Boulevard
Boston, Massachusetts 02178

MAILED 8/12/82 PRE-SORTED

Howard Goodman
Goodman Building
2350 Alder
Norfolk, Virginia 23563

1 PAUSE 2 3 4 5 6 ABORT 7

Notice the record counter in the title/feedback window. This indicates which record is being printed. You can press **ABORT** to display the following special function keys. If **PAUSE** or **ABORT** are pressed while labels are being printed, then the current line of labels is finished before printing is stopped.

The following special functions keys are displayed when **ABORT** is pressed or when all labels are finished printing:

CONTINUE Press this key to resume the printing of output.

EDIT Press this key to edit the output format being accessed. Refer to page 163 for instructions.

SPECS Press this key to display the PRINT SPECIFICATIONS screen.

OUTPUT Press this key to access file records or another output format.

EXIT Press this key if you are finished using FILE/80.

The special function keys of the LABELS screen give you several options. You can reprint labels or skip over labels selected for printing. If you press **PAUSE**, these keys are displayed and the printing of labels is temporarily suspended.

CONTINUE Press this key to resume label printing with the record indicated by the record counter.

BACK Press this key to decrement the record counter. This key allows you to make additional copies of the same label.

SKIP Press this key to increment the record counter. This allows specific labels to be skipped.

DISPLAY Press this key to specify whether or not labels are displayed on your screen.

PRINTER Press this key to specify whether or not your HP-86/87 sends printing information to your printer.

Note: You cannot turn both the display and printer to OFF.

ABORT Press this key to display the special function keys described under pressing **ABORT** earlier.

RESTART Press this key to print all labels over again, beginning with the first label.

Changing Labels

Any characteristic of an output format can be easily changed. First, you load the FILE/80 program and press **(RUN)**. After you press **OUTPUT**, enter the file name your output format is stored under. This is the same file you were accessing when defining the output format. Then, press **OUTPUT** on the FILE/80 screen. Enter the name of the output format when the **FORMAT NAME** prompt appears in the title/feedback window. Next, press **EDIT** on the **PRINT SPECIFICATIONS** or **LABELS** screen. FILE/80 then asks you for the name of the new format—you have two options:

When **EDIT** is pressed, FILE/80 asks you for the name of the new format. You have two options:

- Enter the same name you entered on the **OUTPUT** screen. Your original output format is revised with the changes you specify. Only the revised version of the output format is stored on disc.
- Enter a different name than the one entered on the **OUTPUT** screen. A separate output format is stored on disc. This output format is just like the original except for the changes you make.

After entering the name of the output format on the **PRINT SPECIFICATIONS** or **LABELS** screen, the **LABEL FORMAT** screen is displayed. You can change the printing order of labels, change text entries, add fields, move fields, or delete fields from your label.

How to Change Text

- a. Press **LAYOUT** on the LABEL FORMAT screen.
- b. Use the cursor keys to move the cursor over the text you want to change.
- c. Press **SPACE BAR** or **BACK SPACE** to move the cursor over the old text. This “erases” text from your label.
- d. Key in the new text directly from your keyboard.
- e. Press **ACCEPT** on the LABEL LAYOUT screen.

How to Move Fields

- a. Press **LAYOUT** on the LABEL FORMAT screen.
- b. Press **MOVE** on the LABEL LAYOUT screen.
- c. Position the cursor over the field you wish to move.
- d. Press **PICK** on the MOVE FIELD screen.
- e. Use the cursor keys to move the field to the new location.
- f. Press **PUT** on the PUT FIELD screen.
- g. Press **ACCEPT** on the LABEL LAYOUT screen.

How to Delete Fields

- a. Press **LAYOUT** on the LABEL FORMAT screen.
- b. Press **DELETE** on the LABEL LAYOUT screen.
- c. Position the cursor over the field you wish to remove.
- d. Press **PICK** on the DELETE FIELD screen.
- e. Press **ACCEPT** on the LABEL LAYOUT screen.

CLIENTS File Output Format: LABEL

Dimensions

Height: 1.5 inches

Width: 4.0 inches

Fields

	Line	Col.
Date field obtained by pressing DATE	2	13
FIRST NAME	4	6
LAST NAME	4	22
ADDRESS 1	5	6
ADDRESS 2	6	6
CITY/STATE	7	6
ZIP CODE	8	31

Text Entries

MAILED	2	6
PRE-SORTED	2	26

Sort Fields

ZIP CODE **ASCEND**

Defaults

Defaults are entered by pressing **DEFAULTS** on the PRINT SPECIFICATIONS screen, after storing an output format on disc.

Printer address Set this to the address of your printer. This should not be the same as any disc addresses being used.

Printer type Refer to appendix C for the proper setting.

Number of copies: 1

Labels across: 2

Justify: YES

Reuse sorted list: NO

Search Conditions

These conditions are entered after pressing **SEARCH** on the PRINT SPECIFICATIONS screen. Move the cursor over the LAST CONTACTED field. Enter 06/30/82. Then press **RETURN**, **▶**, and **ACCEPT**. Labels are only printed for records with an entry later than 06/30/82 in the LAST CONTACTED field.

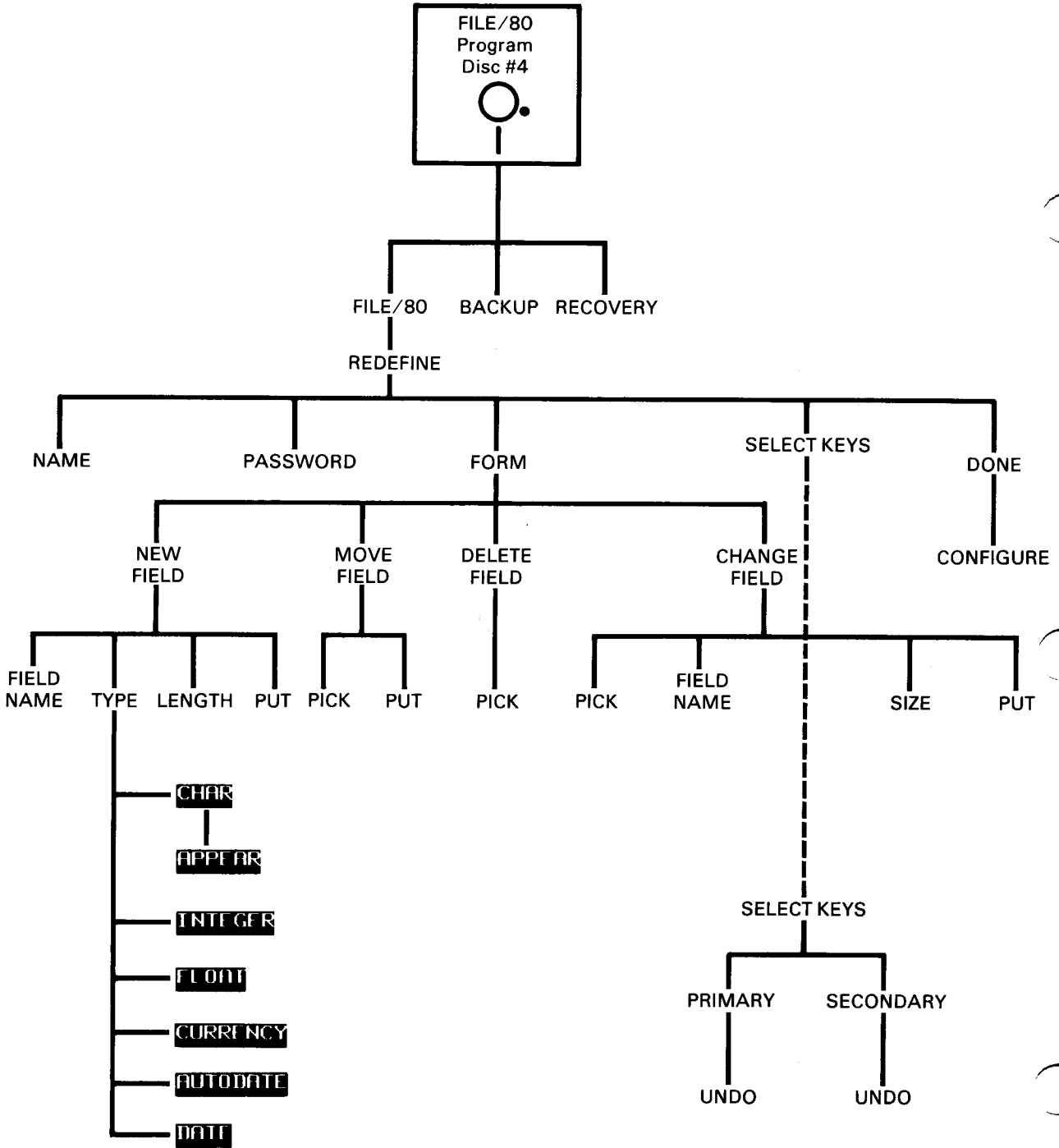

REDEFINE Diagram

Changing Master Forms

Introduction

FILE/80 gives you the capability to modify many characteristics of the master form. This process is easy because the same special function keys are used for changing the master form as were originally used when creating it with the CREATE FORMS special function keys. Any text entries or fields on the master form can be changed. You can enter a new name and/or password for your file. Primary and secondary key designations can be changed. And as your application grows, the number of records in your file can be increased. This section tells you how to make these and many other changes to your files.

The flexibility and ease of use offered with FILE/80 gives you maximum productivity from your HP-86/87. Compatibility between your actual application and the disc files supported by FILE/80 is easy to maintain. The REDEFINE screen enables you to make changes to every record in your file by changing fields and text on the master form or by reordering your file.

Making Backup Files

It is *required* that backup copies of your files be made before and after each file redefinition. A backup copy *must* be generated just prior to each use of the REDEFINE screen. It is recommended that an extra backup copy be made to insure that a current copy of your files will be available should power to your disc drives be interrupted while using the REDEFINE screen.

To make backup copies, you can use the BACKUP utility program stored on FILE/80 Program Disc #4. Another possibility is using the COPY command to manually backup each disc file. If the COPY command is used, it is necessary to use special names for all backup disc files. The disc file naming convention used by FILE/80 and instructions for using the BACKUP utility program are presented in section 9.

Instructions

After making backup copies for the file you wish to modify, you can proceed to modify your original file. Keep the backup copies of your file in a safe place. In addition to providing a reserve copy of your files, FILE/80 may instruct you to insert the backup discs when changes are made to the size of your file. Adding fields to your master form or increasing the number of records in your file can also necessitate the use of backup discs. These changes can be very time-consuming.

To change your file, load the FILE/80 program from FILE/80 Program Disc #4 and press (RUN). Original copies of your disc files need to be in disc drives attached to your HP-86/87. (If space is available, a backup copy of your files can also be on-line.) Press **0101111**.

When the prompt requesting you to enter the file name is displayed, enter the current name of the file you wish to change. If the file has a password, it must be entered as well. After verifying the MSUSs, press **REDEFINE** on the FILE/80 screen.

Press **REDEFINE**

```

FILE NAME: CLIENTS          ** FILE/80 **          TODAY'S DATE: 08 13 83
Please select a special function key.
:
1 QUERY  2 OUTPUT  3 REDEFINE  4 TABS  5 DEFAULTS  6 EXIT  7 DONE
    
```

FILE/80 Display

Next, FILE/80 reminds you that backup copies are needed before redefining a file. Press **EXIT** if you need to make backup copies or **CONTINUE** to display this screen. To make changes to the text or fields on your master form, press **FORM**.

Press **FORM**

```

FILE NAME: CLIENTS          ** REDEFINE **          PASSWORD: HP
Please select a special function key.
-----
ACCOUNT# 0000-NNNN          CHANEY, MANN, AND HILL          PHONE# (NNN) NNN-NNNN
                          Consulting Engineers
                          CLIENT QUICK REFERENCE FILE

LAST MODIFIED ON 00/00/00
LAST NAME# 0000
FIRST NAME# 0000
MIDDLE INITIAL# 00
COMPANY# 0000
1 NAME  2 PASSWORD  3 FORM  4 KEYS  5 _____  6 EXIT  7 DONE
    
```

FILE/80 Display

This screen is similar to the `CREATE FORMS` screen covered in section 2. In addition to changing text or fields on the master form, the `REDEFINE` screen gives you the following options:

NAME Press this special function key to change the file name. The current file name is the one you enter after pressing **OLD FILE** on the `FILE/80` screen. The next time you access this file, the new name must be used. If the original file has a password, it must be entered to access the new file.

Note: File names can contain uppercase or lowercase letters or digits and have a maximum length of eight characters.

PASSWORD Press this special function key to change or remove the password for your file. A prompt appears in the title/feedback window. To remove the password, just press `END LINE`. To change the password, enter the new password and press `END LINE`. Passwords can contain a maximum of 10 characters.

FORM To change any text or fields on your master form, press **FORM**. You can remove, change, or enter new text. Field names can be changed and the length of fields can be increased. Fields can also be moved on the master form. In addition to changing fields already on your master form, fields can be deleted or added using the same special function keys available with the `CREATE FORMS` screen.

KEYS If you want to change any primary or secondary key designations, press **KEYS**. The `SELECT KEYS` screen is displayed with the current master form in the information window. Any current primary keys are listed in the title/feedback window. You can also check the search/sort indicators for any primary or secondary key designations. To change keys, position the cursor on the field you wish to change and then press **PRIMARY** or **SECOND**. To clear key designations for any field, position the cursor over the field and press **UNDO**. There must be at least one field on your master form for **KEYS** to appear on the `REDEFINE` screen.

EXIT Press this special function key if you wish to leave your master form the same and return your HP-86/87 to calculator mode. If you reloaded the `FILE/80` program and pressed `RUN` any changes made to your file with the `REDEFINE` screen are not recognized—your file remains unchanged.

DONE Press **DONE** when all the changes have been made to your master form, including any changes to your primary or secondary keys. After pressing **DONE**, you can change the size of your file and use the **CONFIGURE** special function key to execute *mass storage commands*.

This screen is displayed after you press **FORM** on the `REDEFINE` screen. This screen enables you to change text on the master form directly from your HP-86/87 keyboard. Any changes made to the master form on this screen are not permanent until **DONE**, on the `REDEFINE` screen, is pressed. In other words, you can press **ACCEPT** on this screen, make other changes to your file, and then press **FORM** again to make additional changes to your master form.

```

** REDEFINE **
Form Line 1 Column 1
-----
ACCOUNT###-###-####          PHONE###(###) ###-####
                                CHANEY, MANN, AND HILL
                                Consulting Engineers
                                CLIENT QUICK REFERENCE FILE

LAST MODIFIED ON###/###/###
LAST NAME###
FIRST NAME###
MIDDLE INITIAL###
COMPANY###
1. NEW 2. MOVE 3. DELETE 4. CHANGE 5. COUNT 6. SPACE 7. ACCEPT

```

FILE/80 Display

You can look over the master form with **CONT** and **ROLL**. **CONT** displays successive 15-line segments with a 3-line overlap. **ROLL** scrolls the master form line-by-line. To move the master form up on your display, press **CONT** or hold **SHIFT** and press **ROLL**. To move the master form downwards, press **ROLL** or hold **SHIFT** and press **CONT**.

These special function keys enable you to easily change the master form:

NEW Press this special function key to add a new field to your master form. FILE/80 prompts you for the field name, type, and length. After defining the field, you position it on the master form with the cursor keys. When individual records in your file are accessed, new fields contain blanks. A zero is placed in each new numeric field.

MOVE Press this special function key to move fields on the master form. These fields can be ones originally on the master form or fields added during the current session. Fields cannot be placed over text or other fields. When you move a field from one place to another, the entries for each file record remain intact.

DELETE Any field currently on your master form can be removed by pressing **DELETE**. When you press **DELETE**, FILE/80 displays the DELETE FIELD screen. This screen lets you pick any field on your master form for deletion. Use *caution* when using the DELETE FIELD screen. When a field is deleted, the entries for each record in your file are lost. The field is not deleted until you press **PICK** on the DELETE FIELD screen. If the field you are deleting is designated as a key, refer to page 177 for additional information.

CHANGE When you press this special function key, FILE/80 displays the CHANGE FIELD screen. After you select a field with the cursor, you press **NAME** or **SIZE**. You can change the field name or increase the field length. When the size of a field is changed, the information entered on each record can be changed. Details are provided under **Changing Fields**, page 173.

COUNT Pressing this special function key tells you how many fields are currently on your master form. This total includes any deletions or additions made in the current session. FILE/80 displays this message in the title/feedback window.

SPACE Press this special function key to see how many character equivalents are being used by fields, on your master form. Remember, the combined length of all fields on your master form cannot exceed 1,020 character equivalents. You can refer to the table of **Character Length Equivalents** on page 55.

ACCEPT This special function key can be pressed after changes to fields and text on the master form have been made. After pressing **ACCEPT**, additional changes can be made by pressing **FORM** again.

As a reminder, all changes to the master form (except file size) must be made before pressing **DONE**. After pressing **DONE**, enter the file size and press **END LINE**. Then press **ACCEPT** to store the files listed on disc. After records are transferred, the FILE/80 screen is displayed. This procedure is covered in section 2 and on pages 177-180 of this section.

How to Change Text

Text can be added to, modified, or removed from your master form. Press the **FORM** special function key on the REDEFINE screen before entering text. Text can only be entered when the cursor is displayed in the information window of the REDEFINE screen.

Adding Text: Position the cursor where text is to be added. Then enter the characters directly from your HP-86/87 keyboard. If you make a mistake, the **BACK SPACE** or **SPACE BAR** keys can be used to “erase” characters from your display.

Modifying Text: Display the text you wish to change in the information window. Position the cursor over the text that needs to be changed. Enter the new characters directly from your keyboard.

Removing Text: Position the cursor so it is adjacent to the text you wish to remove. Move the cursor over the unwanted text with **SPACE BAR** or **BACK SPACE**.

If no additional changes need to be made to the master form, press **ACCEPT**. If no changes to the keys for your file need to be made, press **DONE**.

How to Add Fields

Adding fields to your master form increases the storage requirements for your files. This can require using a new initialized disc for storing the “new” files. This can be very time-consuming.

- a. Verify the REDEFINE screen is on your HP-86/87 display.
- b. Press **NEW**. FILE/80 displays the NEW FIELD screen.
- c. A prompt in the title/feedback window requests you enter the name (optional) of the new field. You can enter the field name and press **ENDLINE**. Field names can contain any non-control HP-86/87 keyboard characters and have a maximum length of 27. If you wish to omit the field name, press **ENDLINE** without entering anything.
- d. The following special function keys are presented for you to choose the type of the new field:
CHAR **INTEGER** **FLOAT** **CURRENCY** **AUTODATE** **DATE** **NUMBER**

Press the special function key to specify the type of field to be added to your master form. FILE/80 displays the type of the new field in the title/feedback window. Press **ABORT** if you wish to change the field name.

- e. FILE/80 prompts you for the length of the field. Enter the length (in digits) from the keyboard or numeric keypad and press **ENDLINE**. Use **BACKSPACE** to edit the field length before pressing **ENDLINE**. You can refer to the **Field Length Table** on page 44.

When you choose a character field type, the **APPEAR** key is displayed for entering a formatted character field. You can press **APPEAR** to specify numeric or character positions in the field. As explained in section 2, formatted character fields allow FILE/80 to check for digits when records are added or updated in your file. Insertion characters can be entered directly from your keyboard.

- f. The **PUT** special function key is displayed. The cursor keys can be used to move the field. When the field is in the desired location, press **PUT**.
- g. FILE/80 then displays the REDEFINE screen.
- h. If you are finished making changes to the master form, press **ACCEPT**.
- i. If you don't need to change keys, press **DONE**.

Moving Fields

When you change the position of a field on your master form, the information stored in the field remains intact. Any field on your master form can be moved.

- a. The REDEFINE screen must be on your HP-86/87 display.
- b. Press **MOVE**. The MOVE FIELD screen is displayed. If **MOVE** is pressed accidentally, press **PUT** before moving the field.
- c. Position the cursor over the field you wish to move and press **PICK**.
- d. Use the cursor keys to move the field to the desired location on your master form.
- e. Press **PUT**. You cannot place the field over text or other fields.
- f. The REDEFINE screen is displayed.

- g. If you are finished making changes to the master form, press **ACCEPT** .
- h. If the keys don't need to be changed, press **DONE** .

How to Delete Fields

Use *caution* when deleting fields. After a field has been deleted, the information stored in it cannot be retrieved.

Note: When you delete fields, more space becomes available for storing other fields on the master form. You can press **SPACE** before and after deleting a field to observe this change.

- a. The **REDEFINE** screen must be displayed.
- b. Press **DELETE** . The **DELETE FIELD** screen is displayed. If **DELETE** is pressed accidentally, then press **ABORT** .
- c. Position the cursor over the field you wish to remove.
- d. Press **PICK** .
- e. The **REDEFINE** screen is then displayed.
- f. If you are finished making changes to the master form, press **ACCEPT** .
- g. If the keys for your file don't need to be changed, press **DONE** .

Changing Fields

Both the length and name of fields on your master form can be changed. The **CHANGE FIELD** screen includes two special function keys, **NAME** and **SIZE**, for changing these items. Because changing the size of a field can increase the overall size of your file, an additional disc can be needed when your "new" master form is stored. Remember, you may only *increase* field size.

- a. The **REDEFINE** screen must be on your display.
- b. Press **CHANGE** .
- c. Position the cursor over the field you wish to change with **END LINE** .
- d. Press **PICK** . This screen is displayed:

You can change either the name or length of the field selected with these special function keys:

NAME Press this key to change the name of the field.

SIZE Press this key to increase the size of the field.

ABORT Press this key to select a different field for changing.

- e. Press either **NAME** or **SIZE** .

- f. If you pressed **NAME** in step e, you are prompted to enter the field name. Enter the new field name and press **END LINE**.

OR

If you pressed **SIZE** in step e, you are prompted to enter the field length. You can enter the new length and press **END LINE**. This length must be greater than or equal to the length already defined for the field.

OR

If you pressed **SIZE** and are changing a formatted character field, this screen is displayed. You may only append to formatted character fields and not change their current configuration.

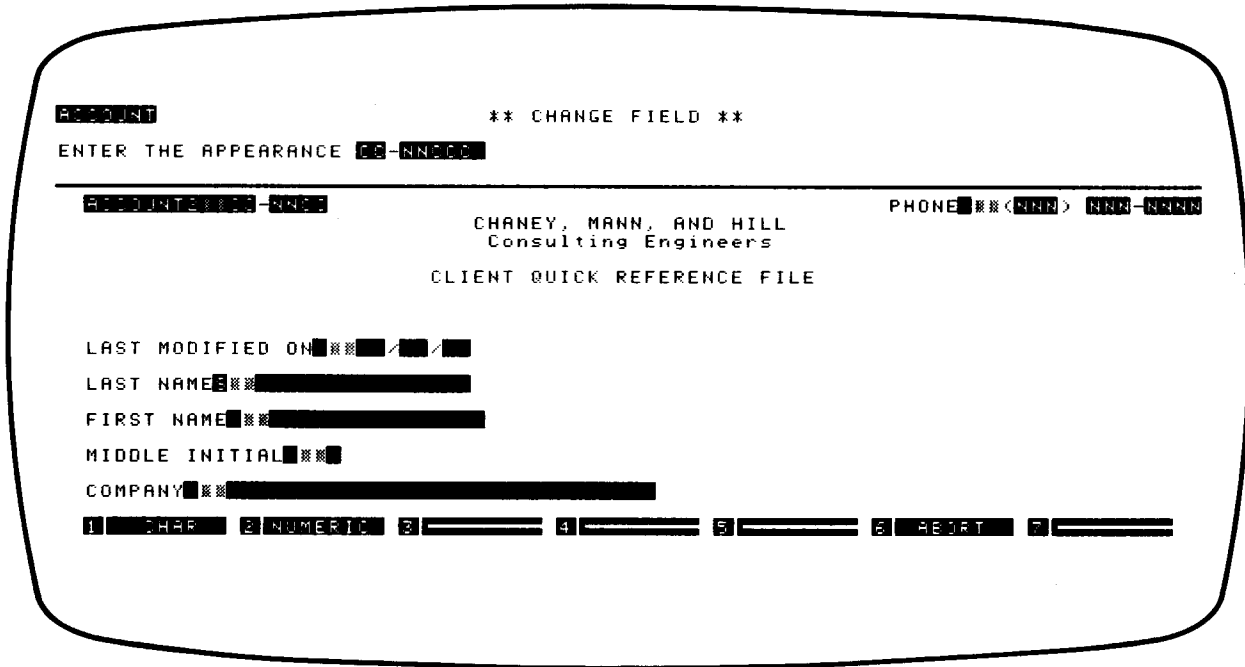

FILE/80 Display

The above screen shows changing the length of the **ACCOUNT** field on the **CLIENTS** master form. To add another character position to the **ACCOUNT** field, press **CHAR** followed by **END LINE**.

Note: Insertion characters can be entered directly from the keyboard.

- g. The **PUT FIELD** screen is displayed.

- h. You can use the cursor keys to move the field (optional). This can be necessary if changes in either the length of the field name or the field itself cause overlapping with other fields or text already on your master form.
- i. Press **PUT**.
- j. The **REDEFINE** screen is displayed.
- k. If you are finished making changes to the master form, press **ACCEPT**.
- l. If you don't need to change any keys, press **DONE**.

Changing Keys

Changing key designations can cause reorganization of your files. Changing the primary key from unique to non-unique is an example of this. Changing key designations can be very time-consuming. To change primary or secondary keys for your file, press **KEYS** on the **REDEFINE** screen. Then the **SELECT KEYS** screen is displayed.

Note: The time required for changing keys is only required when the new master form is stored on disc, after **DONE** is pressed.

```

ACCOUNT          ** SELECT KEYS **          UNIQUE PRIMARY KEY
PRIMARY 1 CLASSIFICATION          PRIMARY 2 ACCOUNT
PRIMARY 3 PROJECT

-----
ACCOUNTS: 3000-4000          PHONE: ***<NNN> NNN-NNNN

          CHANEY, MANN, AND HILL
          Consulting Engineers

          CLIENT QUICK REFERENCE FILE

LAST MODIFIED ON: ##/##/##
LAST NAME: ##
FIRST NAME: ##
MIDDLE INITIAL: ##
COMPANY: ##

1 PRIMARY  2 SECOND  3 UNDO  4 _____  5 UNIQUE  6 _____  7 ACCEPT

```

To change keys, you move the cursor over the field you wish to change and press the appropriate special function key:

PRIMARY Press this key to designate the field the cursor is over as a primary key field. The order of this field in relation to other fields selected for the primary key is indicated in the title/feedback window. A maximum of four fields can be designated for the primary key.

SECON Press this key to designate the field the cursor is over as a secondary key field. Up to four fields can be selected as secondary keys.

UNDO Press this key to clear the field the cursor is over. Both primary and secondary key designations are cleared.

UNIQUE Press this key to change the primary key designation from unique to non-unique, or vice versa. The current designation is displayed in the title/feedback window.

ACCEPT Press **ACCEPT** when each field on the master form has the correct key designation. The **REDEFINE** screen is displayed.

Note: At least one primary key field must be designated for your file before it can be stored on disc.

The following instructions show you how to reorganize your files by changing the fields designated for the primary key. These instructions detail changes to secondary keys as well.

- a. Press **KEY:** on the **REDEFINE** screen. The **SELECT KEYS** screen is displayed.
- b. Check the list of primary key fields in the title/feedback window. Identify the first field in the list you wish to change. This could be field number 2, for instance, if you didn't wish to change field number 1.
- c. Move the cursor over the field with the greatest primary field number.
- d. Press **UNDO** to clear key primary and secondary key designations for the field the cursor is over.
- e. Repeat steps c and d until all fields with a number greater than, and finally equal to, the field you identified in step b have been removed from the list in the title/feedback window.
- f. Move the cursor over the next field you wish to designate as a primary key field.
- g. Press **PRIMARY**.
- h. Repeat steps f and g until all the fields for the new primary key have been designated.
- i. To designate a secondary key, move the cursor over the field to be designated and press **SECON**. Any secondary keys cleared in step d can be restored.
- j. Check over the list in the title/feedback window to verify that the order of the primary key fields you selected is correct.
- k. Press **ACCEPT**.
- l. The **REDEFINE** screen is displayed.
- m. If you are finished making changes to the master form and keys, press **DONE**.

Effects of Changing Keys

You should remember that keys are the organization linkage of your file and that any change to them will have an effect on your file as a whole. Some things to watch out for include:

- Don't delete all of your current keys and then add a new field as the only primary key. This will mean that every record in your file will be a duplicate as the new key will be blank.
- Autodate fields as a part of the primary key are fine, but you should not designate an autodate field to be the only primary key. This will cause the date to be updated during the redefinition session with the current date and all the key fields will be duplicates.

Always use caution when adding, modifying, or deleting keys; think through the results prior to the actual change and all should be well.

Output Formats

Depending on the changes to your file, the `Reuse sorted list` default and/or all output formats defined for a file can become inaccessible. The following table indicates the results of specific file changes. When the `Reuse sorted list` default is *invalid*, the list must be regenerated the next time the output format is used. If the output format is marked *invalid*, then it must be defined and stored on disc again. When an output format or the `Reuse sorted list` default is *valid*, then the change indicated has no effect.

Effects of File Changes

Type of Change	Reuse Sorted List Default	Output Format
File Name Password Text	Valid	Valid
Add Field(s) Delete Field(s) Size of Field(s)	Invalid	Invalid
Key(s)	Valid	Valid (see note)
File Size	Invalid	Valid

Note: If a key field designated as a sort field is changed so it is no longer a key, then sorting will be needed the next time the output format is used.

How to Change File Size

Before changing file size, verify that all other changes have been made. After you press **DONE** on the `REDEFINE` screen, only the maximum number of records can be changed. This number can be either greater or less than your current file size. However, you cannot specify a file size less than the number of records

already entered. If you decide to leave the size of your file the same, enter the old file size and press **END LINE**. If you haven't entered a number yet, just press **END LINE**.

- a. All discs for storing the new file must be on-line.
- b. Press **DONE** on the **REDEFINE** screen.
- c. Enter the new maximum number of records from your keyboard or numeric keypad. This number cannot be less than the number of records currently entered in your file.
- d. Press **END LINE**.
- e. If the disc space on-line is not sufficient to store your file, a message is displayed. You can reduce the maximum number of records, press **EXIT** to cancel all changes, or use **CONFIGUR** for executing mass storage commands.
- f. If disc space is available, then a tentative arrangement of files is displayed.

Note: The **EXIT** key is provided to cancel all changes made with the **REDEFINE** screen. If **EXIT** is pressed, the file is corrupt (some files may have been purged by **FILE/80**) and all remaining related disc files should be purged by you. A list for the **CLIENTS** file is presented under **Use of File Names** on page 188. Before it can be accessed, the original file needs to be recreated with backup copies.

Choosing File Size

Before storing your new file, **FILE/80** automatically packs the disc(s) it will be stored on. This way, the maximum amount of space is always available for the new files. Then a tentative arrangement of your files is displayed in the information window. Two special function keys are provided:

ACCEPT Press this key to store your new file on the discs currently on-line. If you still wish to change the number of records to be included in the file, do not press **ACCEPT**.

ABORT If you wish to change the file size now displayed in title/feedback window, press **ABORT**. **FILE/80** prompts you to enter the number of maximum records again.

By pressing **ABORT** you can determine the maximum number of records that can be stored on the discs currently on-line. You can enter any number of records as long as it is greater than or equal to the number of records currently stored in your file. If no additional discs are required, the tentative arrangement is displayed as before. This means sufficient space is available on the discs you have on-line.

To determine if additional records can be stored in the space available, you can alternately press **ABORT** and increase the maximum number of records. If additional records cannot be stored, a message is displayed to insert an initialized disc or purge unneeded files. If extra space is not available, press **ABORT** and reduce the maximum number of records.

Finally, when a satisfactory arrangement of files is displayed in your information window, press **ACCEPT**:

Press **ACCEPT**

RECORDS ENTERED: 30 ** REDEFINE ** FILE SIZE: 33 RECORDS

Please select a special function key.

FILE NAME	VOLUME NAME	VOLUME NAME	NUMBER OF RECORDS
CLIENTS_R	:D701	_____	_____
CLIENTS_A	:D701	_____	_____
CLIENTS_B	:D701	_____	_____
CLIENTS_C	:D701	_____	_____
CLIENTS_D	:D701	_____	_____
CLIENTS_I	:D701	_____	33

1	2	3	4	5	6	7	8	9	0	REDEF	ACCEPT
---	---	---	---	---	---	---	---	---	---	-------	--------

FILE/80 Display

When **ACCEPT** is pressed, FILE/80 stores your new file according to the arrangement displayed on the screen. This is when the backup copy of your file can be needed. If you need to insert a backup disc file, FILE/80 displays a message requesting the disc file needed. You can remove FILE/80 Program Disc #4 to provide an additional volume of storage; do not remove any data disc(s), however. When the disc with the correct file has been inserted, press **CONTINUE**.

Note: If necessary, you can press **CONFIGUR** to obtain a disc catalog. Refer to section 8 for instructions.

As FILE/80 creates your new file, it is possible that changes made to the keys of your file can cause duplicate primary keys. For example, if the primary key was changed from social security number to last name, then two or more records with the same last name are possible.

If you have specified a unique primary key, the number of duplicates is indicated by a counter in the title/feedback window of the REDEFINE screen. After the new file has been created and a unique primary key has been specified, FILE/80 lets you modify these records to eliminate duplicate entries in the primary key fields.

Note: If you press **ABORT** during the creation of a new file, your file is incomplete and therefore corrupt. You must purge all of the remaining disc files supporting this file. A listing of these files for the CLIENTS file is provided under **Use of File Names** on page 188. The original file can now only be accessed with backup copies.

When your new file has been created, this REDEFINE screen is displayed if you have specified a unique primary key and duplicate primary keys have occurred. Individual file records are displayed in the information window for updating. On this screen, you can change field entries and press **ACCEPT** to eliminate duplicate primary keys. As each record is made unique, the counter in the title/feedback window shows the number of remaining duplicates.

If necessary, position the cursor over the primary key fields and change specific entries to make a record unique. Changing the last character of an entry is often all that is required. Remember, primary key fields display a **1**, **2**, **3**, or **4** in the key indicator. Press **ACCEPT** after changing each record.

```

*** REDEFINE **      5 Primary keys are not unique

-----
ACCOUNT 3**P1-838E                                     PHONE_***(813) 999-1234
                                     CHANEY, MANN, AND HILL
                                     Consulting Engineers
                                     CLIENT QUICK REFERENCE FILE

LAST MODIFIED ON_**08/13/88
LAST NAME 3**JohnE
FIRST NAME_**Paul
MIDDLE INITIAL_**T
COMPANY_**Scientific Equipment, Inc.
1 RESTORE  2 _____  3 _____  4 _____  5 ABORTALL  6 ABORT1  7 ACCEPT

```

FILE/80 Display

The following special function keys can be used:

RESTORE Press this key to display the original entries of the file record on the screen.

ABORTALL Press this key to delete all the records with duplicate primary keys from your file.

ABORT1 Press this key to delete the record currently displayed.

ACCEPT Press this key after making the primary key fields unique. The next duplicate record is displayed for updating.

When the redefinition process is complete, the FILE/80 screen is displayed. To return your HP-86/87 to calculator mode, press **EXIT**. Depending on the changes that were made, tab settings and defaults for adding file records may not have been preserved.

You now have a new file and, at this point, your backup copies are useless (except for archival purposes). New backup copies must be made before the REDEFINE screen can be used again.

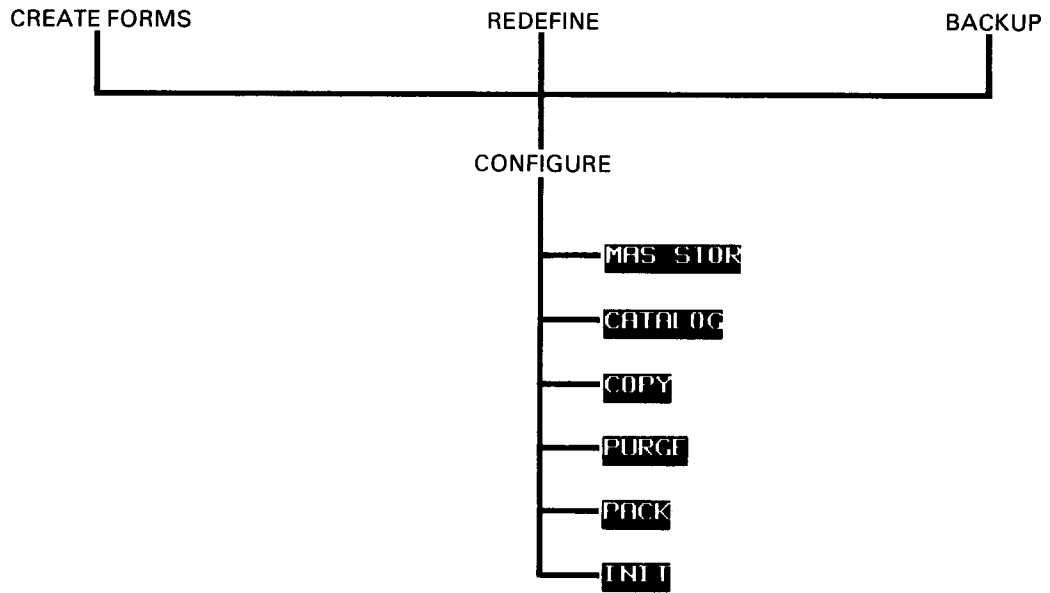

CONFIGURE Diagram

The following special function keys are always provided:

MS STOR Press this key to change the default MSUS location.

CATALOG Press this key to display a listing of files on a disc. You can press **ROLL** or **SHIFT ROLL** to scroll the listing.

COPY Press this key to copy disc files onto other discs.

PURGE Press this key to delete any file on-line.

PACK Press this key to pack all the files on a given disc. This causes larger contiguous spaces to be available for storing other disc files.

INIT Press this key to initialize a disc on-line. When a disc is initialized, *all* files stored on it become inaccessible.

Note: This key differs from the system command. The volume to be initialized can only be specified by a volume name or an MSUS enclosed in quotes.

DONE Press this key after executing mass storage commands. The screen you pressed **CONFIGUR** on is displayed.

The special function keys you choose to use depend on what mass storage commands you are executing. The reason for pressing **CONFIGUR** varies with the current screen. These include the **CREATE FORMS**, **REDEFINE**, **BACKUP**, **LOAD**, and **UNLOAD** screens. For specific instructions on using mass storage commands, refer to the operator's literature provided with your HP-86/87.

Notes



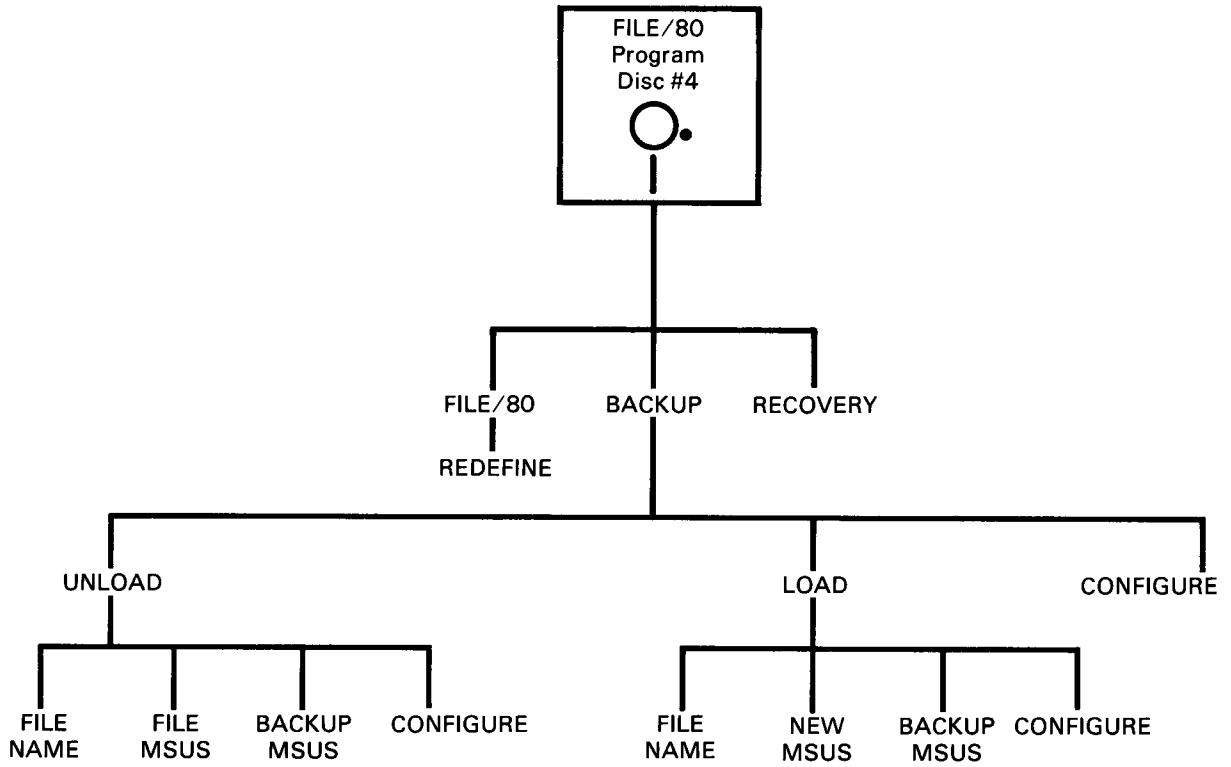

BACKUP Diagram

File Backup

This section tells you how to protect your files by making duplicate copies of them. Instructions for using these duplicates—or *backup*—files when your files become damaged or lost are included. It is recommended you familiarize yourself with the procedures in this section so you are prepared for restoring your files, should the need ever arise.

Introduction

Backing up files means making copies of them. Copies of your files should be made for safety reasons. The BACKUP program, stored on FILE/80 Program Disc #4, provides a convenient means of backing up your files. When backup copies are made, a strict naming convention must be used to assure that original and backup copies can be distinguished.

It is recommended that you backup all the disc files maintained by FILE/80 to insure they remain accessible. If you frequently make updates to your file, then backup copies should be made more often. If your files become damaged, you could use the RECOVERY program (covered in section 10). However, using the RECOVERY program can be very time-consuming and in some cases only part of a file can be restored. If backup copies of your file are available, then the BACKUP program can be used to quickly regain access to your files.

Use of File Names

Depending on the size of your files, you might wish to copy the disc files maintained by FILE/80 individually instead of using the BACKUP program. The COPY mass storage command can be used. These disc files are the same files listed on the CREATE FORMS and REDEFINE screens, just after entering the maximum number of records for your file. The name of each disc file partly depends on the file name you enter when accessing your file. If the file name you enter is CLIENTS, for example, then the following disc files can be present:

Master Form File	Primary Key File	Secondary Key Files	Data Files	Output Format Files
CLIENTS_R	CLIENTS_A	CLIENTS_B CLIENTS_C CLIENTS_D CLIENTS_E	CLIENTS_1 CLIENTS_2 CLIENTS_3 CLIENTS_4 CLIENTS_5 CLIENTS_6 CLIENTS_7 CLIENTS_8 CLIENTS_9 CLIENTS_0	REPORT_S PROJECT_S LETTER_T MEMO_T LABEL_L MAILING_L

Whenever you backup your files, all the files maintained by FILE/80 to support your application must be copied. Not all of these files may be present. However, each file that *is* present must be copied onto a *different* disc than the original is stored on. Either copy the files individually or use the BACKUP program. All the information FILE/80 needs for your application is contained in these files. You should only access these files with the FILE/80, BACKUP, and RECOVERY programs.

BACKUP Naming Convention

When backup copies of your disc files are made, two digits are added to the file name to distinguish the original file from the backup copy. This assures that no two files of the same name are on-line. When a backup copy of a disc file stored on hard disc is made, several backup files can be created.

Original File Name	Backup File Name(s)
CLIENTS_R	CLIENT_R01
FILE_R	FILE_R01
CLIENTS_1	CLIENT_101 CLIENT_102 CLIENT_103 CLIENT_104

The digits 01 are appended to the name of the disc file when a backup copy is made. If the new length of the file name exceeds 10, then characters are removed from the file name beginning with the character to the left of the underscore. If necessary, additional characters are truncated from the end of the file name. In the case of CLIENTS_R, the S is removed. If the length of the file name and the two digits is 10 or less, then no characters are removed from the original file name.

The truncation of file names can cause several unique file names to be reduced to duplicate backup file names. For example, SAMPLE01_L and SAMPLE02_L will both be backed up to SAMPLE_L01. If this occurs, back the files up onto separate discs and keep a record as to which disc contains which original file.

If you use the COPY command to make your backup copies, then you must follow the BACKUP naming convention. When backup copies are made for files stored on a hard disc, then the BACKUP program should be used. When there isn't sufficient space for storing a backup copy on a flexible disc, then the digits 01, 02, etc. are used for storing each segment of the original file on flexible discs.

Making Backup Files

The instructions that follow present a procedure for making backup copies of your file with the BACKUP program. It is recommended two copies of backup files be kept at all times.

- a. Execute the `CAT` command to identify each disc file used by FILE/80 to maintain your file. The *exact* names of the master form file, the primary key file, the secondary key files, the data files, and any output format files need to be written down for reference. When you record the file name, also record the MSUS of the drive it will be copied from.
- b. Initialize at least one flexible disc for each disc your original file is stored on. For files stored on hard disc, several flexible discs can be needed for backing up one large disc file. Record the current date on the discs.
- c. Load the BACKUP program stored on FILE/80 Program Disc #4 from the default drive. This command can be used:

```
LOAD "BACKUP"
```

- d. Press `(RUN)`.
- e. The BACKUP screen is displayed. FILE/80 Program Disc #4 can now be removed to make room for a backup disc, if necessary. Insure that the backup disc is on-line and is not write protected.
- f. Press `UNLOAD`.
- g. The following prompt is displayed on the UNLOAD screen:

```
ENTER THE NAME OF THE FILE TO BE UNLOADED
```

- h. Refer to the list of files you made in step a for the name of a disc file and MSUS where it is located.
- i. Enter the file name without quotes and press `(ENDLINE)`.
- j. The following prompt is displayed:

```
ENTER THE MSUS OF THE DISC WHERE THE FILE IS
```

- k. Enter the digits of the MSUS you recorded for the file in step a and press `(ENDLINE)`.
- l. The following prompt is displayed:

```
ENTER THE MSUS OF THE BACKUP DISC
```

- m. Enter the digits of the MSUS of the flexible backup disc and press `(ENDLINE)`.
- n. The disc file identified in step i is copied to the flexible disc.
- o. If space is exhausted on the backup disc, a prompt to insert an additional initialized disc is displayed. When this occurs, remove the backup disc and insert the next disc you prepared in step b. Note which backup disc the file is continued on.

Note: If an initialized disc is not available, you can press `CONFIGURE` and initialize a disc.

- p. When the disc file identified in step i has been transferred to the backup disc, the **BACKUP** screen is displayed.
- q. Repeat steps f through p until backup copies of all the disc files identified in step a have been made.
- r. Press **[XIT]** on the **BACKUP** screen when you are finished making backup copies.

Using Backup Files

To use backup files, you can run the **BACKUP** program or use the **COPY** command. If you use the **COPY** command, the original file names presented under **BACKUP Naming Convention** described on page 188 must be used. The **BACKUP** program automatically uses this convention. To use the **BACKUP** program for restoring your files, follow these instructions.

- a. Locate the backup discs and the list of file names recorded in step a of **Making Backup Files** on page 189. Be sure each backup disc was created during the same session.
- b. Load the **BACKUP** program stored on **FILE/80 Program Disc #4** from the default drive.
- c. Press **(RUN)**.
- d. When the **BACKUP** screen is displayed, press **LOAD**. You can remove **FILE/80 Program Disc #4** now to make room for an additional disc, if necessary. Place the disc on-line and be sure that it is not write protected.
- e. The **LOAD** screen is displayed.
- f. When prompted, enter the name of a disc file from the list referenced in a. It is important the specific file name be entered. Do not use quotes.
- g. Enter the digits of the **MSUS** of the disc where the new files can be stored.
- h. Then enter the digits of the **MSUS** of the drive where the backup disc is located.
- i. If your file was segmented when the backup copy was made, you can be instructed to insert a specific backup disc file.
- j. The **BACKUP** screen is displayed.

Note: You can press **CONFIGUR** to purge unneeded files and/or pack a disc if additional space is needed for the restored file.

- k. Repeat steps d through j until the names of each disc file on the list have been entered.
- l. Press **[XIT]**.
- m. To access your files, load the **FILE/80** program and press **(RUN)**.

Notes

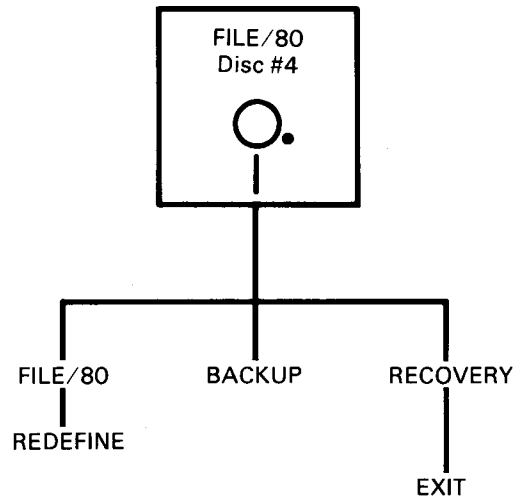

RECOVERY Diagram

File Recovery

This section explains how to restore your files if they become inaccessible and recent backup files are not available. If a power outage occurs when updates are being made to your file, for example, it is possible your file can require special processing before it can be accessed. Such files are termed *corrupt*. The RECOVERY program can be used to “repair” your files when recent backups aren’t available. But in some cases, only part of a corrupt file can be restored.

How to Recover Files

These instructions explain how to use the RECOVERY program. All the discs containing the *corrupt* file need to be on-line while the RECOVERY program is running.

- a. Load the RECOVERY program from FILE/80 Program Disc #4. This disc should be in the default drive. You can use this command:

```
LOAD "RECOVERY"
```

- b. Press **[RUN]**. The RECOVERY screen is displayed.

Note: If necessary, you can remove FILE/80 Program Disc #4 to provide an additional volume of storage.

- c. When prompted, enter the file name.
- d. If requested, enter the MSUS where the disc file ending with `_R` is located. For example, if the file name is CLIENTS, then this file would be CLIENTS_R.
- e. If prompted, enter the password.
- f. Check over the table of MSUSs on-line. For your files to be restored properly, each volume where the corrupt file is stored must be present.
- g. Press **[ACCEPT]**.
- h. Your files are restored.
- i. A message is displayed after your files have been restored.

Note: Use of the RECOVERY program can be very time-consuming. Depending on the size of your files, the time required for restoration can vary from several minutes to several hours.

C

C

C

FILE/80 Screen-Special Function Key Summary

Whenever you are running the FILE/80 program, there will be a preformatted display on the screen of your HP-86/87. Each one has a name which appears in the title/feedback window. It is offset by double sets of asterisks like this: ** ADD **. These formats are referred to as screens. Following is an alphabetical listing of the screens available with FILE/80. Refer to page 201 for a listing of the special function keys.

ADD

Accessed by pressing the **ADD** special function key on the **QUERY** screen. It enables you to add records to your file. The **ADD** screen provides the special function keys **CLEAR**, **COUNT**, **CALC**, **BATCH**, **ABORT**, and **ACCEPT**.

BACKUP

Displayed when the **BACKUP** program is running. This program is stored on FILE/80 Program Disc #4. The purpose of loading this program is to create or use backup copies according to a naming convention required by FILE/80. The special function keys available on this screen are **UNLOAD**, **LOAD**, **EXIT**, and **CONFIGUR**.

BREAK FIELDS

Accessed by pressing the **BREAKS** special function key on the **REPORT FORMAT** screen. It is used to designate sort fields as break fields. This determines when new pages or subtotals are printed on reports. (Subtotals are selected using the **REPORT TRENDS** screen.) The special function keys available on the **BREAK FIELDS** screen are **CONTROL**, **PAGE**, **UNDO**, **CLEAR**, **ABORT**, and **ACCEPT**.

CHANGE FIELD

Accessed by pressing the **CHANGE** special function key on the **REDEFINE** screen. It allows you to modify the name or length of a field on the master record. These changes affect every record in your file simultaneously. The special function keys available on this screen are **NAME**, **APPEAR**, **SIZE**, and **ABORT**.

COMPUTED FIELD

Accessed by pressing the **COMPUTED** special function key on the **FIELD SELECTION** screen. It is used to enter an expression for computations that are performed for individual records in a report or letter. The special function keys available on the **COMPUTED FIELD** screen are **PICK**, **CONSTANT**, **SHOW**, **RUB OUT**, and **ABORT**.

CONFIGURE

Accessed by pressing the **CONFIGUR** special function key on the CREATE FORMS, REDEFINE, BACKUP, LOAD, or UNLOAD screens. It lets you execute mass storage commands on an HP-86/87 while the FILE/80 program is running. The special function keys available on this screen are **MAS STOR**, **CATALOG**, **COPY**, **PURGE**, **PACK**, **INIT**, and **DONE**.

CREATE FORMS

Shown after you press the **NEW FILE** special function key, specify a date format, enter a currency sign, and enter the MSUSs of drives on-line. The CREATE FORMS screen is used for creating the master form. The special function keys are **NAME**, **PASSWORD**, **FORM**, **KEYS**, **DONE** and **CONFIGUR**.

- When you press the **FORM** special function key the **NEW**, **MOVE**, **DELETE**, **COUNT**, **SPACE**, and **ACCEPT** special function keys are provided.

DEFAULTS (for adding records)

Accessed by pressing the **DEFAULTS** special function key on the FILE/80 screen. It is used to make entries in fields that are automatically posted to forms displayed on the ADD screen. The special function keys available on this screen are **CLEAR** and **ACCEPT**.

DEFAULTS (for printing)

Accessed by pressing the **DEFAULTS** special function key on the PRINT SPECIFICATIONS screen. It enables you to specify the printer address, printer type, number of copies, and other defaults for an output format. The special function keys available on the DEFAULTS screen are **CHANGE**, **ABORT**, and **ACCEPT**.

DELETE

Accessed by pressing the **DELETE** special function key on the QUERY screen. It allows you to remove records from a file. The special function keys available are **ABORT** and **ACCEPT**.

DUMP ALL

Accessed by pressing **DUMP ALL** on the OUTPUT screen. It is displayed while the master form summary and individual file records are printed. The **PAUSE** and **ABORT** keys enable you to control the printing of records.

- If **PAUSE** is pressed, the **CONTINUE**, **DISPLAY**, **PRINTER**, **PAUSE**, and **RESTART** keys are displayed.
- If **ABORT** is pressed, the **CONTINUE**, **EDIT**, **SPECS**, **OUTPUT**, and **EXIT** keys are displayed.

FIELD SELECTION

Accessed by pressing the **FIFIT** special function key on the REPORT LAYOUT screen. It enables you to choose fields from your file records for printing in reports. The special function keys available are **PICK**, **COMPUTIT**, and **ABORT**. If a report output format is being accessed, then the **HEADING** key is also displayed.

FILE/80

Displayed when you start a session with the FILE/80 program. After you press **NEW FILE** or **OLD FILE**, you are prompted to enter the file name, an optional password, and the following information:

- If you press **NEW FILE**, you are requested to select a format for dates, choose a currency sign, and enter the current date. Finally, you enter the printer address and the MSUS of each drive on-line. The **MM DD YY**, **DD MM YY**, and **YY MM DD** special function keys are used to select the date format. Next, the character for separating the month, day, and year is selected by pressing one of these special function keys:

MM/DD/YY	DD/MM/YY	YY/MM/DD
MM.DD.YY	DD.MM.YY	YY.MM.DD
MM-DD-YY	DD-MM-YY	YY-MM-DD

- If you press **OLD FILE**, you are requested to enter the current date and verify the printer address and the MSUSs of all drives on-line. The **QUERY**, **OUTPUT**, **REDEFINE**, **TABS**, **DEFAULTS**, **EXIT**, and **DONE** special function keys are then provided.

LABELS

Accessed by pressing the **PRINT** special function key on the **PRINT SPECIFICATIONS** screen. It allows you to interrupt the printing of labels. The **PAUSE** and **ABORT** special function keys are available.

- If you press **PAUSE**, then the **CONTINUE**, **BACK**, **SKIP**, **DISPLAY**, **PRINTER**, **ABORT**, and **RESTART** special function keys are provided.
- If you press **ABORT**, then the **CONTINUE**, **EDIT**, **SPECS**, **OUTPUT**, and **EXIT** keys are displayed.

LABEL DIMENSIONS

Accessed by pressing the **LABELS** special function key on the **OUTPUT TYPE** screen. You can enter the dimensions (height and width) for the label being defined. The special function keys provided on this screen include **HEIGHT**, **WIDTH**, **ABORT**, and **ACCEPT**. The special function key **cm.** is pressed to select metric labels. When label dimensions are in centimeters, the **in.** special function key is displayed.

LABEL FORMAT

Accessed by pressing **ACCEPT** on the **LABEL DIMENSIONS** screen. Also accessed by pressing **EDIT** on the **LABELS** or **PRINT SPECIFICATIONS** screen. The appearance and printing order for your labels can be specified. The special function keys provided are **LAYOUT**, **SORT**, **ABORT**, and **DONE**.

LABEL LAYOUT

Accessed by pressing the **LAYOUT** special function key on the **LABEL FORMAT** screen. It allows you to enter text and arrange fields on the label. The special function keys available are **FIELD**, **DATT**, **DELETE**, **MOVE**, **ABORT**, and **ACCEPT**.

LETTER

Refer to the LABELS screen summary.

LETTER FORMAT

Refer to the LABEL FORMAT screen summary.

LETTER LAYOUT

Refer to LABEL LAYOUT screen summary.

LOAD

Accessed by pressing **LOAD** on the BACKUP screen. It is displayed when backup files are being used to re-create original files. The **ABORT**, **CONFIGUR**, and **CONTINUE** special function keys are provided.

NEW FIELD

Accessed by pressing the **NEW** special function key on the CREATE FORMS screen. It is used to define fields on the master form. At first only the **ABORT** special function key is provided.

- After you enter a field name, the **CHAR**, **INTEGER**, **FLOAT**, **CURRENCY**, **AUTODATE**, **DATE**, and **ABORT** special function keys are provided.
- If you press the **CHAR** special function key, the **APPEAR** and **ABORT** special function keys are provided.
- If you press the **APPEAR** special function key, the **NUMERIC** and **CHAR** special function keys are provided.
- Then you position the new field on the master form with the cursor keys. The **PUT** and **ABORT** special function keys are provided.

OUTPUT

Accessed by pressing the **OUTPUT** special function key on the FILE/80 screen. Also accessed by pressing **OUTPUT** on the DUMP ALL, LABELS, LETTER, or REPORT screens. You are prompted to enter the name of the output format being defined or accessed. The special function keys provided are **DUMP ALL** and **ABORT**.

OUTPUT TYPE

Accessed by entering the name of an output format that is not on-line. You choose the type of the output format with this screen. The special function keys available are **REPORT**, **LETTER**, **LABELS**, and **ABORT**.

PRINT SPECIFICATIONS

Displayed when **DUMP ALL** is pressed or the name of an output format on-line is entered on the OUTPUT screen. It is also displayed by pressing **DONE** on the REPORT FORMAT, LETTER FORMAT, or LABEL FORMAT screens. Pressing **SPECS** on the DUMP ALL, LABELS, LETTER, or REPORT screens also displays the PRINT SPECIFICATIONS screen. This screen enables you

to select records for printing, to change output formats already stored on disc, and to start the printing of output. The special function keys provided are **EDIT**, **DEFAULTS**, **SEARCH**, **ABORT**, and **PRINT**.

PUT FIELD

Accessed by pressing **PICK** on the **FIELD SELECTION** screen or **⊖** on the **COMPUTED FIELD** screen. The **PUT FIELD** screen allows you to arrange fields on reports, letters, and labels with the cursor keys. The **PUT** and **ABORT** special function keys are provided.

QUERY

Displayed when the **QUERY** special function key on the **FILE/80** screen is pressed. You can add records to your file or access records for displaying, updating, or deleting. The **ADD**, **SEARCH**, **NEXT**, **PREVIOUS**, **UPDATE**, **DELETE**, **UNDO**, and **DONE** special function keys are available.

RECOVERY

Displayed when the **RECOVERY** program is running. This program can be used to restore files that have been marked *corrupt*. The **EXIT** special function key is provided.

REDEFINE

Accessed when the **REDEFINE** special function key is pressed on the **FILE/80** screen. It enables you to change the master form after it has been stored on disc, even if records have been added to your file. The **NAME**, **PASSWORD**, **FORM**, **KEYS**, **EXIT**, **DONE** and **CONFIGUR** special function keys are available.

- If you press **FORM**, then the **NEW**, **MOVE**, **DELETE**, **CHANGE**, **COUNT**, **SPACE**, and **ACCEPT** special function keys are provided.
- If duplicate primary keys result from changes you make, then the **RESTORE**, **ABORTALL**, **ABORT**, and **ACCEPT** special function keys are displayed when the revised file is stored on disc.

REPORT

Displayed when **PRINT** is pressed on the **PRINT SPECIFICATIONS** screen when a report output format is being accessed. It lets you interrupt the printing of a report. The special function keys provided are **PAUSE** and **ABORT**.

- If you press **PAUSE**, then the **CONTINUE**, **DISPLAY**, **PRINTER**, **ABORT**, and **RESTART** special function keys are provided.
- If you press **ABORT**, the **CONTINUE**, **EDIT**, **SPECS**, **OUTPUT**, and **EXIT** keys are provided.

REPORT BODY

Accessed when **ACCEPT** is pressed on the **REPORT LAYOUT** screen. It is used to select the headings, body, and footing for your report. The **INCREASE**, **DECREASE**, **ABORT**, and **ACCEPT** special function keys are provided.

REPORT FORMAT

Accessed by pressing the **REPORT** special function key on the **OUTPUT TYPE** screen. Also accessed by pressing **EDIT** on the **PRINT SPECIFICATIONS** or **REPORT** screen. Every screen used to specify reports can be accessed from this screen. The special function keys provided are **LAYOUT**, **SORT**, **BREAKS**, **TRENDS**, **ABORT**, and **DONE**.

REPORT LAYOUT

Accessed by pressing the **LAYOUT** special function key on the **REPORT FORMAT** screen. You can enter text and arrange fields on your report. The **FIELD**, **PAGE #**, **DATE**, **MOVE**, **DELETE**, **ABORT**, and **ACCEPT** special function keys are provided.

REPORT TRENDS

Accessed by pressing the **TRENDS** special function key on the **REPORT FORMAT** screen. You can specify totals and statistics for fields in your report. The special function keys provided are **GRAND**, **SUB**, **MEAN**, **MIN/MAX**, **UNDO**, **ABORT**, and **ACCEPT**.

SEARCH

Accessed by pressing the **SEARCH** special function key on the **QUERY** screen. Any record or group of records in your file can be retrieved. The special function keys available are **RELATION**, **RANGE**, **ANY CHR**, **XMATCH**, **FORM 1**, **FORM 2**, **ABORT**, and **ACCEPT**.

- If you press the **RELATION** special function key, the **=**, **<>**, **>**, **>=**, **<**, **<=**, and **INCL** special function keys are provided.
- If you press the **RANGE** special function key, the **LO BOUND**, **HI BOUND** and **UNDO RNG** special function keys are provided.

SELECT KEYS

Accessed by pressing **KEYS** on either the **CREATE FORMS** or **REDEFINE** screens. You can designate primary and/or secondary fields for your file. The special function keys provided are **PRIMARY**, **SECOND**, **UNDO**, **UNIQUE**, and **ACCEPT**.

SHOW COMPUTED

Displayed when **SHOW** is pressed on the **COMPUTED FIELD** screen. You can choose the computed fields for use in the expression being entered. The special function keys provided are **PICK** and **ABORT**.

SORT

This screen is displayed when **PRINT** is pressed on the **PRINT SPECIFICATIONS** screen. The screen remains on the display until all necessary sorting has been performed. The **ABORT** special function key is provided.

SORTED LABEL

Accessed by pressing the **SORT** special function key on the LABEL FORMAT screen. You can select up to five fields on the master form as sort fields. The special function keys provided are **ASCEND**, **DESCEND**, **UNDO**, **ABORT**, and **ACCEPT**.

SORTED LETTER

Refer to the SORTED LABEL screen summary.

SORTED REPORT

Displayed when you press **SORT** on the REPORT FORMAT screen. You can choose up to five sort fields from the master form. These fields are used to order a report. When printing subtotals, any break fields must first be designated as sort fields. The **ASCEND**, **DESCEND**, **UNDO**, **ABORT**, and **ACCEPT** special function keys are provided.

TABS

Accessed by pressing the **TABS** special function key on the FILE/80 screen. You can select up to 10 fields on the master form for tab stops. When the ADD, DEFAULTS, FIELD SELECTION, SEARCH, and UPDATE screens are displayed, for example, you can press **CONT** or **SHIFT CONT** to tab forwards or backwards. The **SET TAB**, **CLEAR**, and **ACCEPT** special function keys are available.

UNLOAD

Accessed when the BACKUP program is running. It is displayed when backup copies of your files are being made. The **ABORT**, **CONFIGURE**, and **CONTINUE** special function keys are provided.

UPDATE

Accessed by pressing the **UPDATE** special function key on the QUERY screen. You can change data in fields of a file record. The special function keys provided are **RESTORE**, **CALC**, **SHOW DUP**, **ABORT**, and **ACCEPT**.

Special Function Key Summary

Keys	Screens Provided On	Functions
ABORT	ADD	Clears the record being added.
	BREAK FIELDS	Clears all break fields.
	CHANGE FIELD	Clears changes entered for a field when redefining a file.
	COMPUTED FIELD	Clears the computed field being defined.

Keys	Screens Provided On	Functions
ABORT	CREATE FORMS	Clears the form being defined.
	DEFAULTS	Cancel any changes to defaults.
	DELETE	Saves a record from being deleted.
	DUMP ALL	Stops the printing of file records.
	FIELD SELECTION	Cancel selection of an additional field for a report, letter, or label.
	FILE/80	Displays the previous screen.
	LABELS	Stops the printing of labels.
	LABEL DIMENSIONS	Displays the OUTPUT screen.
	LABEL FORMAT	Clears a label output format and displays the LABEL DIMENSIONS screen.
	LABEL LAYOUT	Clears the fields and text on a label.
	LETTER	Stops the printing of a letter.
	LETTER FORMAT	Clears a letter output format and displays the OUTPUT screen.
	LETTER LAYOUT	Clears all fields and text on a letter.
	LOAD	Stops the retrieval of backup files.
	NEW FIELD	Clears the field being defined.
	OUTPUT	Displays the FILE/80 screen.
	OUTPUT TYPE	Displays the OUTPUT screen.
	PRINT SPECIFICATIONS	Displays the OUTPUT screen.
	PUT FIELD	Removes the field being placed on an output format.
	REPORT	Stops the printing of a report.
	REPORT BODY	Displays the REPORT LAYOUT screen.
	REPORT FORMAT	Clears a report output format and displays the OUTPUT screen.
	REPORT LAYOUT	Clears all trends, fields, and text on a report.
	REPORT TRENDS	Clears all trends on a report.
	SEARCH	Cancel any search conditions.
	SHOW COMPUTED	Displays the COMPUTED FIELD screen.
SORT	Terminates the search currently underway.	

Keys	Screens Provided On	Functions
ABORT	SORTED LABEL SORTED LETTER SORTED REPORT	Cancels all sort fields for an output format.
	UNLOAD	Stops creation of backup files.
	UPDATE	Displays the original record on the QUERY screen.
ABORTALL	REDEFINE	Deletes all records with duplicate primary keys.
ABORT1	REDEFINE	Deletes the record with duplicate primary keys on the screen.
ACCEPT	ADD	Adds the record displayed to a file.
	BREAK FIELDS	Selects the break fields displayed.
	CREATE FORMS	Selects the text and fields entered on the master form.
	DEFAULTS	Sets the defaults displayed.
	DELETE	Removes the record displayed from a file.
	FILE/80	Verifies that the MSUSs are complete and correct.
	LABEL DIMENSIONS	Selects the dimensions in the title/feedback window.
	LABEL LAYOUT LETTER LAYOUT	Selects the fields and text currently on an output format.
UPDATE	Makes the changes displayed to a file record.	
ADD	QUERY	Displays a blank form for entering information onto.
APPEAR	NEW FIELD CHANGE FIELD	Designates positions for a formatted character field.
ASCEND	SORTED LABEL SORTED LETTER SORTED REPORT	Designates a field on the master form as an ascending sort field for an output format.
AUTODATE	NEW FIELD	Selects an autodate type field for a master form.
BACK	DUMP ALL LABELS LETTER	Selects specific records for additional printing.
BATCH	ADD	Adds a record to a file and then displays a blank form for adding one more record.
BREAKS	REPORT FORMAT	Designates break fields for reports.
CALC	ADD UPDATE	Performs addition, subtraction, multiplication, or division operations on a file record.
CATALOG	CONFIGURE	Displays the catalog listing of a disc on-line.

Keys	Screens Provided On	Functions
CHANGE	DEFAULTS	Selects the default setting to be changed.
	REDEFINE	Selects fields on the master form to be changed.
CHAR	NEW FIELD CHANGE FIELD	Selects a character type field for master forms. If a character type field has already been selected, then this key can be used to specify character positions in a formatted character field.
CLEAR	ADD	Clears all the fields on the record displayed.
	DEFAULTS	Clears all the fields on the default record used for adding records.
	TABS	Removes a tab stop specified for the field the cursor is over.
cm	LABEL DIMENSIONS	Displays the centimeter defaults for label height and width.
COMPUTED	FIELD SELECTION	Defines a computed field for a report or letter.
CONFIGUR	BACKUP CREATE FORMS LOAD FILE/80 REDEFINE UNLOAD	Enables execution of mass storage commands.
CONSTANT	COMPUTED FIELD	Enters a constant into an expression for a computed field.
CONTINUE	DUMP ALL LABELS LETTER REPORT	Resumes printing of an output format or file record.
	FILE/80 LOAD RECOVERY UNLOAD	Indicates that a requested disc has been put on-line.
CONTROL	BREAK FIELDS	Designates a break field for printing subtotals.
COPY	CONFIGURE	Executes the COPY command.
COUNT	ADD	Displays the number of records currently in a file.
	CREATE FORMS REDEFINE	Displays the number of fields currently on the master form.
CURRENCY	NEW FIELD	Selects a currency type field for the master form.
DATE	FILE/80	Changes the date entered at the beginning of the session.

Keys	Screens Provided On	Functions
DATE	LABEL LAYOUT LETTER LAYOUT REPORT LAYOUT	Places a date field on an output format.
	NEW FIELD	Selects a date type field on a master form.
DD MM YY	FILE/80	Selects a day-month-year ordering for dates.
DD/MM/YY DD.MM.YY DD MM YY	FILE/80	Selects the slash, period, or hyphen insertion character for date fields.
DECREASE	REPORT BODY	Reduces the number of lines printed with each record on a report.
DEFAULTS	FILE/80	Enters data into fields on the form used for adding records.
	PRINT SPECIFICATIONS	Displays the defaults used for printing output.
DELETE	CREATE FORMS REDEFINE	Deletes a field on the master form.
	FILE/80	Deletes a MSUS from the list of drives on-line.
	LABEL LAYOUT LETTER LAYOUT REPORT LAYOUT	Deletes a field on an output format.
	QUERY	Selects the record displayed for deleting.
DESCEND	SORTED LABEL SORTED LETTER SORTED REPORT	Designates a descending sort field for an output format.
DISPLAY	DUMP ALL LABELS LETTER REPORT	Select whether or not output is displayed on the screen as it is produced.
DUMP ALL	OUTPUT	Prints copies of individual file records along with a master form summary.
DONE	CONFIGURE	Displays the screen CONFIGUR was pressed on.
	CREATE FORMS REDEFINE	Requests the file size after selecting fields, text, and keys for a master form.
	FILE/80	Displays the OLD FILE and NEW FILE special function keys.

Keys	Screens Provided On	Functions
DONE	LABEL FORMAT LETTER FORMAT REPORT FORMAT	Stores an output format on disc.
	QUERY	Displays the FILE/80 screen.
EDIT	LABELS LETTER PRINT SPECIFICATIONS REPORT	Edits output formats already stored on disc.
EXIT	BACKUP DUMP ALL FILE/80 LABELS LETTER RECOVERY REDEFINE REPORT	Returns the HP-86/87 to calculator mode.
FIELD	LABEL LAYOUT LETTER LAYOUT REPORT LAYOUT	Adds a new field to an output format.
FLOAT	NEW FIELD	Selects the float field type.
FORM	CREATE FORMS REDEFINE	Enables the changing of fields or text on a master form.
FORM 1	SEARCH	Displays the original form search conditions were entered on.
FORM 2	SEARCH	Displays an alternate form for entering search conditions.
GRAND	REPORT TRENDS	Selects grand totals for a field on a report.
HEADING	FIELD SELECTION	Changes the auto heading indicator.
HEIGHT	LABEL DIMENSIONS	Changes the height of a label.
HI BOUND	SEARCH	Displays the high bound entered for a range search.
in.	LABEL DIMENSIONS	Displays the default label height and width for inches.
INCL	SEARCH	Searches for records with a specific character sequence.
INCREASE	REPORT BODY	Increases the number of lines printed with each record on a report.

Keys	Screens Provided On	Functions
INIT	CONFIGURE	Initializes a disc. Only the volume name and MSUS parameters can be used.
INTEGER	NEW FIELD	Selects an integer type field for the master form.
KEYS	CREATE FORMS REDEFINE	Enables the changing or designating of keys for a file.
LABELS	OUTPUT TYPE	Selects a label output format.
LAYOUT	LABEL FORMAT LETTER FORMAT REPORT FORMAT	Enables the entering of fields and text for an output format.
LETTER	OUTPUT TYPE	Selects a letter output format.
LOAD	BACKUP	Begins the retrieving of backup files.
LO BOUND	SEARCH	Displays the low bound entered for a range search.
MAS STOR	CONFIGURE	Executes the MASS STORAGE IS command.
MEAN	REPORT TRENDS	Specifies the printing of an average for the field the cursor is over on a report.
MIN/MAX	REPORT TRENDS	Specifies the printing of minimum and maximum values of a field on a report.
MM DD YY	FILE/80	Selects a month-day-year format for displaying dates.
MM/DD/YY MM.DD.YY MM-DD-YY	FILE/80	Selects the slash, period, or hyphen insertion character for date fields.
MOVE	CREATE FORMS REDEFINE	Moves a field on the master form.
	LABEL LAYOUT LETTER LAYOUT REPORT LAYOUT	Moves a field on an output format.
NAME	CHANGE FIELD	Changes the name of a field on the master form.
	REDEFINE	Changes the name of a file.
NEW	FILE/80	Enters the MSUS of a drive on-line.
	CREATE FORMS REDEFINE	Adds a field to the master form.
NEW FILE	FILE/80	Begins creation of a new file.
NEXT	QUERY	Displays the next record satisfying search conditions.
NUMERIC	CHANGE FIELD NEW FIELD	Specifies a numeric position in a formatted character field.

Keys	Screens Provided On	Functions
OLD FILE	FILE/80	Accesses a file already stored on disc.
ORIGINAL	UPDATE	Displays the updated record with duplicate primary keys.
OUTPUT	DUMP ALL LABELS LETTER REPORT	Enables access of file records and different output formats.
	FILE/80	Selects the printing or creating of an output format.
QUERY	FILE/80	Enables the perusing or changing of records in a file.
PACK	CONFIGURE	Packs a disc on-line.
PAGE	BREAK FIELDS	Specifies subtotals and a new page when breaks occur on a report.
PAGE #	REPORT LAYOUT	Places a page number field on a report.
PASSWORD	CREATE FORMS REDEFINE	Enters a new password.
PAUSE	DUMP ALL LABELS LETTER REPORT	Interrupts the printing of an output format.
PICK	CHANGE FIELD COMPUTED FIELD FIELD SELECTION	Selects the field the cursor is over from the master form.
	SHOW COMPUTED	Selects one computed field for use in another computed field.
PREVIOUS	QUERY	Displays the previous record matching search conditions.
PRINT	PRINT SPECIFICATIONS	Begins the printing of an output format. If necessary, sorting is performed first.
PRINTER	FILE/80	Displays a prompt for changing the printer address.
	LABELS LETTER REPORT	Selects whether or not the HP-86/87 sends information to a printer for output being produced.
PURGE	CONFIGURE	Purges a file on-line.
PUT	CHANGE FIELD NEW FIELD PUT FIELD	Places a field on a master form or output format.
PRIMARY	SELECT KEYS	Designates a field for the primary key.
QUERY	FILE/80	Enables record additions and searches.
RANGL	SEARCH	Enters high and low bounds for a range search.

Keys	Screens Provided On	Functions
REDEFINE	FILE/80	Makes changes to a master form.
RELATION	SEARCH	Specifies a relation search for information entered in a field.
REPORT	OUTPUT TYPE	Specifies a report type output format.
RESTART	DUMP ALL LABELS LETTER REPORT	Resumes the printing of output.
RESTORE	UPDATE	Cancels any changes to the file record being updated.
	REDEFINE	Displays the original entries of a file record with duplicate primary keys.
RUB OUT	COMPUTED FIELD	Removes the last constant, field, or operator from a computed field expression.
SEARCH	QUERY	Enters conditions for displaying file records.
	PRINT SPECIFICATIONS	Enters conditions for accessing records for output.
SECOND	SELECT KEYS	Designates a secondary key for a file.
SET TAB	TABS	Designates a field on the master form as a tab stop.
SHOW	COMPUTED FIELD	Displays a list of expressions for all computed fields. Press this key to use results from one computed field in another.
SHOW DUP	UPDATE	Displays a record with an identical primary key.
SIZE	CHANGE FIELD	Increases the length of a field on the master form.
SKIP	DUMP ALL LABELS LETTER	Skips over specific records to be printed.
SORT	LABEL FORMAT LETTER FORMAT REPORT FORMAT	Designates sort fields for an output format.
SPACE	CREATE FORMS REDEFINE	Displays the number of character equivalents currently being used by fields on the master form.
SPECS	DUMP ALL LABELS LETTER REPORT	Displays the PRINT SPECIFICATIONS screen.
SUB	REPORT TRENDS	Designates the field the cursor is over for subtotals.
TABS	FILE/80	Sets tab stops on the master form.
TRENDS	REPORT FORMAT	Designates totals or statistics for fields on a report.

Keys	Screens Provided On	Functions
UNDO	BREAK FIELDS	Clears the break field designation for the sort field opposite the cursor.
	REPORT TRENDS	Clears all trends specified for a field.
	QUERY	Retrieves a deleted file record.
	SELECT KEYS	Clears primary and secondary key designations for a field.
	SORTED LABEL SORTED LETTER SORTED REPORT	Clears a sort field for an output format.
UNDO RNG	SEARCH	Clears high and low bounds for a range search.
UNIQUE	SELECT KEYS	Selects a unique or non-unique primary key.
UNLOAD	BACKUP	Makes backup copies of a file.
UPDATE	QUERY	Selects the file record on the screen for updating.
WIDTH	LABEL DIMENSIONS	Changes the width of a label.
YY MM DD	FILE/80	Specifies a year-month-day ordering for date fields.
YY/MM/DD YY.MM.DD YY-MM-DD	FILE/80	Selects the slash, period, or hyphen as an insertion character for date fields.
?ANY CHR	SEARCH	Specifies a position in a field for searching that can contain any character.
*MATCH	SEARCH	Indicates a beginning character sequence for a search.
= <= >= < > <>	SEARCH	Accesses records with the indicated relation to data entered in a field.

Sorting

If you choose a specific order of records for an *output format*, FILE/80 performs sorting just before the actual printing occurs. With large files the efficiency of sorting can depend on the amount of total RAM available. When more RAM is available, larger portions of your file can be sorted together. The sorting process takes *less* time and is *more* efficient with this additional RAM.

Sorting efficiency is also determined by the number of records in your file and the sort string length. In general, the shorter the sort string and the smaller the file, the faster sorting will be. The table in this section gives you an idea of how these factors determine the maximum length of the sort string.

To use the table you must determine the number of file records and the total RAM available on your HP-86 or HP-87. These quantities are defined as follows:

- *File Records* This is the total number of records currently stored in your file. This number is displayed on the ADD screen when **COUNT** is pressed. This quantity is not the file size entered as the maximum number of records. It is the total number of actual file records stored in your file that can be included in a report, letter, or label output format.
- *Total RAM* This is the amount of memory included in the mainframe of your HP-86/87 plus the additional bytes of RAM provided by any memory modules.

If you press **SEARCH** on the PRINT SPECIFICATIONS screen to select certain records for output, then a search must be performed to locate these records. This search occurs prior to the sorting of your records. The records that are sorted are those selected with the SEARCH screen. When searches are performed, the sorting of your records can be slower.

By pressing the **DI** special function key on the PRINT SPECIFICATIONS screen you can change the ascending or descending sort fields specified for your output format. This is done by pressing **SORT** on the REPORT FORMAT, LETTER FORMAT, or LABEL FORMAT screens. It is not necessary to press **DI** if your output format hasn't already been stored on disc.

Several maximum sort string lengths are shown in the following table. These lengths are in character length equivalents, defined on page 55 and under **Terms You Will Encounter** (page 7). You can use any sort string length up to and including the maximum length indicated in the table on the following page.

Sort String Limits

		File Records			
		5,000	10,000	40,000	65,000
Total RAM	96	250	200	100	78
	128	250	250	250	200
	160+	250	250	250	250

Default Printer Types

The printer you are using must be assigned a type number on the **DEFAULTS** screen. The default type is 1. To change this default, you must first display the **PRINT SPECIFICATIONS** screen. This screen is displayed after you enter the name of an output format on-line or after you press **DUMP ALL** on the **OUTPUT** screen. Press **DEFAULTS** on the **PRINT SPECIFICATIONS** screen. The Printer type default is always present on the **DEFAULTS** screen. Settings for the Printer type are listed in the table of **Printer Types**.

To insure your printer interprets the information produced by **FILE/80** correctly, you must set the printer default type to the appropriate setting. To specify the printer type, move the cursor to the number beside the Printer type item listed on the **DEFAULTS** screen, and press **CHANGE**. You can press **END LINE** or **(SHIFT) END LINE** to move the cursor. Next, enter the printer type indicated below, press **END LINE** and then **ACCEPT**. It is only necessary to set the printer type once for each output format you store on disc. However, this default must be reset if you are using **DUMP ALL**.

Printer Types

Model	Type
HP 82905A Printer	1
HP 82905B Printer HP 82906A Printer HP 2631B Printer HP 2635B Printer	2
HP 2631A Printer HP 2631G Printer* HP 2635A Printer HP 2671A Printer HP 2671G Printer HP 2673 Printer	3
HP 2601A Printer	4
HP 2602 Printer	5

* Compressed mode on the HP 2631G Printer is different than that on other HP printers. The number of characters per line is 122 instead of 132. Keep this in mind if you are producing reports with over 80 columns on an HP 2631G Printer.

Note: Whenever you anticipate producing hard-copy output, turn on your printer before loading the FILE/80 program and pressing **RUN**. If you turn on the printer while the program is running, your files can be damaged. Instructions for using backup files and restoring files are provided in sections 9 and 10. In some cases, only part of a file can be restored.

Hard Disc Usage

A hard disc storage device can be used to store the FILE/80, REDEFINE, BACKUP, and RECOVERY programs originally stored on the four FILE/80 Program Discs. If you do transfer the files to hard disc, it is recommended you keep the original discs for archive purposes. Any of the Winchester Disc Drives supported by Series 80 computers can be used.

Follow these steps to transfer the FILE/80 program and utilities to a hard disc volume:

- a. Select the volume (hard disc) to be used for storage and determine its MSUS. This could be :D722, for example.
- b. Determine the MSUS of the flexible disc drive for inserting the FILE/80 Program Discs in—this could be :D700.
- c. Insert FILE/80 Program Disc #1 into the flexible disc drive selected in b.
- d. Execute the COPY command to copy the resident files onto hard disc. For example, if the MSUSs are those indicated in a and b, then this command can be used:

```
COPY ":D700" TO ":D722"
```

- e. Repeat steps c through d for FILE/80 Program Discs #2, #3, and #4.

Note: Disregard any duplicate file name error messages.

- f. Execute the CAT command to list all files that have been copied onto the hard disc volume. The CAT ":D722" command could be used.
- g. Verify that these disc files are present on the hard disc volume:

CRFORMS	F/80mesg	FILE/80BIN	MESS2	REDEFLOW
QUERY	F/80START	REPORTHIGH	REPORTLOW	Relowmesg
Createmesg	Startmesg	LABELSHIGH	LABELLOW	BACKUP
Querymesg	BIN15	LETTERHIGH	SORT	Backupmesg
DUMMY_ROOT	BIN24	SPECS	REDEFINE	RECOVERY
FILE/80	STEVIE	RLL_MES	Redemesg	Recovmesg



Index

A

Accessing files, 59-61

Accessing output formats, 128

Accessing records, 59-86

Deletions, 84-86

Locating, 68-70

Procedure, 67

Search summary, 86-88

Updating procedure, 80-84

ACCOUNT field, 15, 22, 47, 50, 56, 67, 174

ACCOUNT field diagram, 47

ACCOUNT field name, 48, 51

ACCOUNT REP field, 16, 56, 132-133, 137, 146

Active keys, 13

ADD screen, 62, 64-65

Adding records, 62-67

Calculating entries, 63

Clearing fields, 62

Defaults, 64-65

Multiple, 64

Tabs, 65-67

ADDRESS 1 field, 56, 136, 146, 165

ADDRESS 2 field, 56, 136, 146, 165

Alternate search conditions, 79-80, 87

PANY CHR, 76-77

Arithmetic hierarchy, 101

Autodate type field, 40, 42

Comparison of entries, 68

Making entries, 64

Averages for reports, 115

B

Backup—files, 167, 187

Making, 189

Using, 190

BACKUP naming convention, 188

BACKUP program, 187-188

BACKUP screen, 183-184, 189-190

BATCH, using, 64

Blank lines default, 117, 119, 124

Boxes, 11

Break diagram, 110

BREAK FIELDS screen, 109, 111, 114

Break sequence, 109

Break_type column, 111

Break types, 111-112

Control, 111, 123

Definition, 110

Page, 111

Bytes, conversion, 55

C

Calculations, performing, 62

Adding records, 62-63

Updating, 81

CATALOG command, 183, 189-190

Changing discs, 19-20, 59, 91, 127, 149

CHANGE FIELD screen, 171, 174

Changing fields, 174

Formatted character, 174

- Changing file size, 177-180
 - During creation, 53-54
- Changing master forms, 167-171
 - Backup requirements, 167
 - Effects on output formats, 177
 - Field length, 174
 - Field names, 173
 - Fields, adding, 171-172
 - Fields, deleting, 173
 - Fields, moving, 172
 - File name, 169
 - File size, 177-179
 - Keys, 175-176
 - Password, 169
 - Primary keys, duplicate, 180
 - Text, 171
- Changing media, **59**, 91, **119-120**, 127, 149
- Character equivalents, 35
 - Length conversion, 55
 - Number on master form, 36, 171
- Character field type, 39-40
 - Comparison of entries, 68
 - Formatted, 46-47
 - Making entries, 64
- Character positions, 46-47
- Characters, insertion, 47-48
- Characters, searching for, 73
- CITY/STATE field, 56, 79, 136, 146, 165
- CLASSIFICATION field, 15, 50, 56, 98-100, 107, 110-112, 123
- CLIENT_R01 file, 188
- CLIENT_101 to CLIENT_104 files, 188
- CLIENTS_A to CLIENTS_E files, 187
- CLIENTS_R file, 187-188, 193
- CLIENTS_0 to CLIENTS_9 files, 187
- CLIENTS file, 11
 - Label, 165
 - Letter, 146-147
 - Master form entries, 55-57
 - Printing output, 23-27
 - Report, 123-124
 - Trends for report, 124
- Commands, mass storage, 183-184
- COMPANY field, 56, 79, 136, 146
- Comparing field entries, 68
- COMPUTED FIELD screen, 102
- Computed fields, 101
 - Deleting, 103
 - Evaluating, 101
 - Letters, 134
 - Reports, 101-103
 - Sample problem, 101
 - Using other computed fields, 102
- Configuration file, 31-33
- CONFIGURE screen, 183
- CONSULTING REQUIREMENTS field, 56, **73**
- Control breaks, **109-112**, 123
- Converting label dimensions, 153
- COPY command, 184
 - File backup, 167, **187-188**
- Corrupt files, 193
- CREATE FORMS screen, 29, 36, 46, 48-49, 51-54
- Creating master forms, 29-57
 - Deleting fields, 49
 - Designating keys, 51-52
 - Designing, 29
 - Entering file size, 53-54
 - Field lengths, 43-44
 - Field types, **39-43**, 46-48
 - Fields, 36-37
 - File size, entering, 53-54
 - Moving fields, 48-49
 - Putting fields, 45-46
 - Sample, 14
 - Selecting keys, 49-51
 - Text entries, 49
- Currency sign, 32-33
- Currency type field, 41-42
 - Comparison of entries, 68
 - Making entries, 64
- Current date, entering, 21, 33

Cursor, 21

- Movement on master form, 36

- Movement on output formats, 98-100, 132, 154

- With tabs, 65-66

D

Data files, 187

Date, entering, 21

Date field, 97, 131, 155

Date type fields, 40, 42

- Configuring, 31-32

- Comparison of entries, 68

- Making entries, 64

Dating labels, 157-158

Defaults, 26, 61

- Changing, 117-118

- Labels, 159-160

- Letters, 141-143

- Reports, 117-119

- Setting for records, 64-65

DEFAULTS screen (for adding records), 65

DEFAULTS screen (for printing), 26, 105, 117,

- 138, 141, 147, 158-160

Defining labels, 151-152

Defining letters, 128-130

Defining reports, 92-96

DELETE FIELD screen, 98, 104, 131, 136, 164,

- 170, 173

DELETE screen, 84-85

Deleting fields, 104

- Computed on reports, 103

- Labels, 155, 164

- Letters, 136

- Master form, 49, 173

Deleting file records, 84-86

- Saving with **UNDO**, 85

Demonstration of FILE/80, 21-27

Demonstration disc, 11

- Accessing, 20-21

- Letter, 16, 27

- Mailing label, 17, 27

- Printing each record, 14, 27

- Reports, 15, 24-27

- Viewing individual records, 22-23

Designating keys, 51-52

Designating sort fields, 107

- Labels, 158

- Letters, 138-140

- Reports, 107-108

Designing reports, 96

Disabled keys, 13

Disc files, 187

- Label, 158

- Letter, 140

- Master form, 54, 179

- Report, 115

Discs, changing, 19-20, 24, 91

DISPLAY IS ON/OFF indicator, 121, 144,

- 162

Dimensions, 27

- Label, 152-153

- Letter, 127, 142

- Report, 96, 118

Disc, hard, 10

:D700 MSUS, 20, 30, 33, 59-60

:D701 MSUS, 20, 30, 33, 59-60

DUMP ALL screen, 27, 94, 115

DUMP ALL, use of, 94, 115-117, 119

Duplicate primary keys, 50

- Adding, 63

- Updating, 84

- With REDEFINE, 180

E

-
- Editing field data, 64
 - Editing output formats, 116
 - Label, 163-164
 - Letter, 140
 - Report, 122
 - Effects of file changes, 177
 - Efficiency, 49-50
 - Also see `Reuse sorted list`
 - Search, 88
 - Sort, 108-109
 - Entering, 21
 - Data into fields, 64
 - Field names, 37-38
 - File size, 53
 - MSUSs, 33-34
 - Output format names, 93, 129, 151
 - Text, 49
 - Estimating file size, 53
 - Exiting FILE/80, 27, 54, 86, 120-121, 145, 180, 190

F

-
- Field entries, 64
 - Comparing, 68
 - Field length, 43-44
 - Choosing numeric, 44
 - Field length table, 44
 - Field name*, 37
 - Field names, 37-38
 - Auto headings, 98-99
 - FIELD SELECTION screen, 98-99, 101, 103, 131, 133, 155
 - Field types, 39-40
 - Autodate, 42
 - Character, 40
 - Currency, 41-42
 - Date, 42-43
 - Float, 41
 - Formatted character, 46-49
 - Integer, 40-41
 - Fields, 36-37
 - Adding, 171-172
 - Changing, 173-175
 - Comparison of entries, 68
 - Computed on letters, 134
 - Computed on reports, 101-103
 - Deleting on labels, 164
 - Deleting on letters, 136
 - Deleting on master form, 49, 173
 - Deleting on reports, 104
 - Editing data, 64
 - Moving on labels, 164
 - Moving on letters, 135
 - Moving on master form, 48-49, 172
 - Moving on reports, 103
 - Number on master form, 36, 171
 - Putting, 45-46
 - Selecting, 98-99
 - Sort, **108-109**, 138-140, 158
 - Use on reports, 98
 - File access, 59-61
 - File name, 31, **60**
 - MSUSs, 33-34, **60-61**
 - Password, 31, 60
 - File changes, effects of, 177
 - File, CLIENTS, 11
 - Label, 165
 - Letter, 146-147
 - Master form, 55-57
 - Report, 123-124
 - File configuration, 31-33
 - FILE/80, 7
 - Demonstration disc, 11
 - Demonstration, 21-27

- Display, 12-13
- Exiting, 27, 54, 86, 120-121, 145, 180, 190
- Program discs, 11
- FILE/80 Pocket Guide*, 7
- FILE/80 screen, 64, 67, 81, 83, 85-86, 92, 116, 128, 150-151, 168-169, 180
- File maintenance, 7
 - Additions, 62-63
 - Automatic, 7, 49-50
 - Deletions, 84-86
 - Procedure for backup, 188-190
 - Updating, 80-83
- File management, 10
 - Phases, 7
- File names, 31
 - Changing, 35, 169
 - Entering to access files, 60
 - Used for backup, 188
- File naming convention, 188
- File records, 29
 - Adding, 62-63
 - Deleting, 84-86
 - Displaying current number, 62
 - Locating with searches, 68-80
 - Printing, 24, 94, 119-121
 - Sample output, 13-17, 56
 - Saving with **UNDO**, 85
- File records, updating, 59
 - Duplicate primary keys, 81, 84
 - Editing field entries, 64, 80
 - Instructions, 80-83
- FILE_R file, 188
- FILE_R01 file, 188
- File recovery, instructions, 193
- File size, 53
 - Changing, 177
- File updating
 - See File records, updating
- Files, backup
 - See Backup files
- Files, disc
 - See Disc files
- Files ending _R, 60, 187, 193
- Files ending _1, 54, 187
- Files ending _2, 54, 187
- FIRST NAME field, 56, 149, 155-156, 165
- First-time usage instructions, 19-20
- Fixed disc
 - See Hard disc
- Flexible disc, 10
- Float type field, 39, 41
 - Comparison of entries, 68
 - Making entries, 64
- Footings, 96, 104-106
- Form, master
 - See Master form
- Form size (Lines) default, 26, 118, 124, 140-142, 147
- Formats,
 - See Output formats
- Format name, 93, 128-129, 151, 187
- FORMAT NAME prompt, 25, 93-95, 129, 151, 163
- Forms creation, starting, 30-34
- Formats
 - See Output formats
- Formatted character fields, 46-47
 - Comparison of entries, 68
 - Insertion characters, 47-48

G

- Grand totals, 114
 - Fields for, 44

H

Hard-copy output, 13-17, 23, 67
 Hard disc, 10
 Hardware requirements, 19
 Headings, 96, **104-106**

Height for labels, 152-153
 Help messages, 12
 HOURS LOGGED field, 56, 67, 74-75, 79-80

I

Identifier, special function key, 12-13
 Inclusion, search with **INCL**, 73
 Indicators, 37
 Search, 88
 Sort, 108
 Information window, 12-13
 INITIALIZE command, 184

Insertion characters, 47
 Insufficient memory, 20
 Integer type field, 39, **40-41**
 Comparison of entries, 68
 Making entries, 64
Invalid format changes, 177

J

Justification, 136-138
 Labels, 158

Letters, 85, 133
 Justify default, 138, 142, 147, 158, 160, 165

K

Key files, 49-50, 187
 Key indicator, **37**, 51-52, 84, 180
 Keys, changing, 175-176
 Keys, designating 51-52
 Keys, duplicate primary, 50

Additions, 63
 Updating, 84
 With REDEFINE, 180

Keys, primary, 49-50
 Keys, secondary, 51

L

Label dimensions, 152-153
 Converting, 153
 Entering, 152
 Metric, 150
 LABEL DIMENSIONS screen, 152-153
 LABEL FORMAT screen, 153, 155, 157-159,
 163-164
 Label formats, storing, 158
 LABEL LAYOUT screen, 153-158
 LABEL output format, 165
 Printing, 27
 Sample output, 17

Label, special function key, 12-13
 LABEL_L file, 187
 Labels across default, **160**, 165
 Labels, 149-151
 Dating, 157
 Defaults, 159-160
 Defining, 150-152
 Dimensions, 150
 Editing, 163-164
 Fields, 155-157, 165
 Justified, 158
 Layout, 153-157

- Order of, **158**, 165
- Printing, 159, **161-163**
- Sample mailing, 17
- Selecting records for, 161
- Size, 150
- Sorting, 158
- Storing, 158
- Text, 154-155
- LABELS screen, 27, 160-162
- LAST CONTACTED field, 42, 56, 74-75, 79-80, 147, 165
- LAST MODIFIED ON field, 42, 56, 82
- LAST NAME field, 37-40, 43, 45, 50-51, 56, 116, 146, 165
- LAST NAME field name, 39-40, 43
- Layout, label, 153-157
 - Date fields, 157
 - Editing, 163-164
 - Fields, deleting, 164
 - Fields, moving, 164
 - Fields, selecting, 155
 - Justified, 158
 - Text, entering, 154
 - Text, removing, 164
- Layout, letter, 130-138
 - Computed fields, 134
 - Fields, deleting, 136
 - Fields, moving, 135
 - Fields, selecting, 133
 - Justified, 136-137
 - Non-justified, 138
 - Text, 132-133
- Layout, report, 97-104
 - Fields, deleting, 103-104
 - Fields, moving, 103
 - Fields, selecting, 98-103
 - Specifying the body of, 104-107
- Length, field, 43-44
- Letter dimensions, 127, **142**
- LETTER output format, 146-147
 - Printing, 27
 - Sample output, 16
- LETTER screen, 27, 140-141, 143-145
- LETTER FORMAT screen, 129, 131, 135, 138, 140, 147
- LETTER LAYOUT screen, 127-128, 130-138
- LETTER_T file, 187
- Letters, 127-147
 - Computed fields, 134
 - Defaults, 141-143
 - Defining, 128-130
 - Deleting fields, 136
 - Editing, 140
 - Fields, 133
 - Layout, 130-138
 - Moving fields, 135
 - Order of, **138-140**, 147
 - Printing, 140-141, **143-145**
 - Putting fields, 134
 - Sample, 16
 - Search conditions, 127, **141**, 147
 - Selecting fields, 133
 - Sorted, 138-139
 - Text, 154, 164
- LOAD screen, 183-184, 190
- LOAD "BACKUP" command, 189
- LOAD "FILE/80" command, 20, 30, 60, 91
- LOAD "RECOVERY" command, 193
- Loading program, 20, 30, 59-60
- Locating file records, 21-23, **68**
 - Deleting, 84-86
 - Searches, 68-80
 - Updating, 80-83
-  , use of, 13

M

-
- MAILING_L file, 187
 - Making backup files, 189-190
 - Manual, use of, 11-12
 - Mass storage commands*, 11, 169, **183-184**
 - Screens for using, 184
 - MASS STORAGE IS command, 20, **183-184**
 - Master forms, 29
 - Printing, 27, **94**, 115-119
 - Sample output, 15, 56
 - Master forms, changing, 167-171
 - Backup requirements, 167
 - Effects on output formats, 177
 - Field length, changing, 174
 - Field names, changing, 173
 - Fields, adding, 171-172
 - Fields, deleting, 173
 - Fields, moving, 172
 - File name, 169
 - File size, 177-179
 - Keys, 175-176
 - Password, 169
 - Primary keys, duplicate, 180
 - Text, 171
 - Master form storage limitations, 35-36
 - Master form summary, 56
 - Features, 94
 - Master forms, creating
 - See Creating master forms
 - MATCH**, 87
 - Starting character(s), 78-79
 - Maximum number of records, 53
 - Changing, 177-179
 - Entering, 53-54
 - Maximum records per page default, 117, 119
 - Media, changing, 19-20, 91
 - MEMO_T file, 187
 - Memory, insufficient, 20
 - Messages, help, 12
 - Metric labels, 150
 - MIDDLE INITIAL field, 56, 165
 - Minimum/maximum values, 115
 - Month day year* format, 32
 - MOVE FIELD screen, 48, 98, 103, 131, 135, 164, 172
 - Moving fields, 48, 172
 - Label, 164
 - Letter, 135
 - Reports, 103
 - Multiple addition of records, 64-65
 - Multiple search conditions, 74-75, 88
 - MSUSs, 20-21
 - Entering, 33-34
 - Verifying, 60-61

N

-
- Names, file
 - See File names
 - Naming convention, file, 188
 - Necessary hardware, 19
 - NEW FIELD screen, 38-40, 43, 45, 171
 - NI X1**, use of, 70
 - Notes, 11
 - Number of copies default, 118, 124, 142, 147, 160, 165
 - Number of file records, 36, 171
 - Numeric positions, 46-47

O

-
- Output format files, 187
 - Output format type, selecting
 - See Selecting output format types
 - Output formats*, 25, 91

CLIENTS label, 165
 CLIENTS letter, 146-147
 CLIENTS report, 123-124
 Type, 91, 93
 Output formats, storing, 115
 Effects of REDEFINE, 177
 Labels, 158
 Letters, 140
 Reports, 115
 Output, sample, 13

Form, 14, 23, 67
 Labels, 17
 Letter, 16
 Master form summary, 56
 Report, 15
 OUTPUT screen, 25, 27, 56, 92-94, 115-117,
 119-121, 127-130, 141, 145, 151, 159, 163
 OUTPUT TYPE screen, 91, 93-95, 127-129,
 151-152
 Overview, 7

P

PACK command, 184
 Page breaks, 109-112
 Passwords, 31
 Changing, 35, 169
 Entering to access files, 60
 PHONE field, 22, 56, 83
PREVIOUS, use of, 70
 Primary key file, 50, 187
 Primary keys, 49-50
 Duplicate, 50, 63, 84
 Duplicate with REDEFINE, 180
 PRIMARY 1 title, 51
 PRINT SPECIFICATIONS screen, 25-27,
 86, 93-94, 115-124, 128, 140, 143, 147, 151,
 158-165
 Printed lines per page default,
 105, 118, 124
 Printer address default, 26, 117-118,
 124, 141, 147, 160, 165
 Printer type default, 26, 117-118, 124, 142,
 147, 160, 165
 Printer usage, 13
 PRINTING IS ON/OFF indicator, 121, 145,
 163
 Printing labels, 159, 161

Order, 158
 Printing letters, 140
 Interrupting, 144
 Starting, 143
 Printing reports, 115-116
 Pausing, 120
 Procedure, 119-121
 PROFITABILITY INDEX field, 41, 56
 Program discs, FILE/80, 11
 Program execution, indication of, 20
 Program loading, 20
 PROJECT field, 15, 23, 50, 56, 67, 81, 123
 PROJECT FROM field, 56, 76-77
 PROJECT_S file, 187
 PROJECT SUMMARY REPORT, 25
 Breaks on, 110
 Diagram, 113
 Printing, 26-27
 Sample output, 15
 PURGE command, 184
 PUT FIELD screen, 99-101, 103, 131-132,
 134-135, 156, 164, 174
 Putting fields, 45

Q

QUERY screen, 12, 23-24, 59, 62, 64, 67-70, 72,
 74-77, 80-86

R

- Range searches, **75-76**, 87
- Record access, 67
 - Deleting, 84-86
 - Search summary, 86-88
 - Searches, 68-70
 - Speed of, 88
 - Tabs, 65-67
 - Updating, 80-83
- Records, adding, 62-63
- Records, locating with searches, 68-70
 - Alternate conditions, 79-80
 - PNY CHR**, use of, 76-77
 - INCL**, use of, 73
 - *MATCH**, use of, 78-79
 - Multiple conditions, 74-75
 - Range searches, 75-76
 - Relation searches, 70-72
 - Summary, 86-88
 - Tabs, using, 65-67
- Records, maximum number of, 53
 - Changing, 117
- Records, order of, 91-92
 - Labels, **158**, 165
 - Letters, **138-139**, 147
 - Reports, **107-108**, 123
 - Sorted list, **119**, 177
- RECOVERY program, 11, 193
- RECOVERY screen, 193
- REDEFINE screen, 11, 167-180
- Relation searches, **70-73**, 86-87
- Removing text, 49
- Report body, selecting, 104-106
- REPORT BODY screen, 96, 98, 104-106, 123
- REPORT FORMAT screen, 95-98, 103, 107-109, 112, 115-116, 122, 124
- Report layout, **97-98**, 104-106
 - Computed fields, 100-103
 - Deleting fields, 103-104
 - Designating body, 106
 - Footings, 96, 104, 118
 - Headings, 96, 104, 118
 - Moving fields, 103
 - Picking fields, **98-99**, 102
 - Putting fields, **99-100**
 - Sample diagram, 113
 - Text, 104
- REPORT LAYOUT screen, 95, 97-101, 103-105, 107, 123
- REPORT output format, 123-124
 - Sample output, 15
- Report records, 104-106
 - Information appearing with, 118
- REPORT_S file, 187
- REPORT screen, 26-27, 94, 115-117, 119-122
- Report trends, 112-115
 - Averages, 115
 - CLIENTS file, 124
 - Grand totals, 114
 - Minimum/maximum values, 115
 - Subtotals, 114
- REPORT TRENDS screen, 112, 114
- Reports, 91-124
 - CLIENTS file, 123-124
 - Column headings, 98-100
 - Computed fields, 100-103
 - Defaults for, 117-119
 - Defining, 91-115, **95-96**
 - Discs to use, 91
 - Editing, 116, **122**
 - Fields, adding, 98-100
 - Fields, deleting, 103-104
 - Fields, moving, 103
 - Format name, 93
 - Layout, see Report layout
 - Modifying, 122
 - Printing, 115-116, **119-121**
 - Sample, 15
 - Selecting heading, 96

Size footing, 96
 Sorted, 107-108
 Storing on disc, 115
 Subtotals, 112, 114
 Text, 104
 Width, 96

Requirements, hardware, 19
 Retrieving records, 68-70
 Reuse sorted list default, 109, 119,
 123, 177
ROLL, use of, 13
→, use of, 13

S

Sample REPORT diagram, 113
 Sample output, 13
 Form, 14
 Labels, 17
 Letter, 16
 Master form summary, 56
 Report, 15
 Sample screen, 12
 Scrolling, 13
 Letters, 132
 Master forms, 36
Scrolling horizontally, 13, 96
 Search conditions, 70-80
 Accessing records with, 68-70
 Alternate, 79-80
 ANY CHR, 76
 FORM 2, 79-80
 Labels, 159, 161, 165
 Letters, 127, 141, 147
 MATCH, 78-79
 Multiple conditions, 74-75
 RANGE, 75-76
 RELATION, 70-72
 Specific character sequences, 73
 Summary, 86-88
 Search efficiency, 88
 SEARCH screen, 22-23, 37, 59, 67-81, 84-88, 91,
 147, 161
Search/sort indicators, 37, 88
 SEARCH summary table, 88
 Secondary key files, 187
 Secondary keys, 51
 Requirements, hardware, 19
 Retrieving records, 68-70
 Reuse sorted list default, 109, 119,
 123, 177
ROLL, use of, 13
→, use of, 13
 SELECT KEYS screen, 49, 52, 169, 175-176
 Selecting keys, 49-50
 Primary, 50
 Secondary, 50-51
 Selecting output format types, 94, 129, 152
 Setting defaults, 64-65
 Setting tabs, 65-66
 SHOW COMPUTED screen, 102
 Size, file, 53
 Changing, 177
 Sort fields, 108-109
 Labels, 158
 Letters, 138
 Omitting, 138
 Reports, 107-108, 112
 Sorted lists, 109, 119
 SORT screen, 116, 119, 141, 143, 160-161
 SORTED LABEL screen, 37, 158, 161
 SORTED LETTER screen, 37, 127, 138
 Sorted lists, 109, 119
 Effects of file changes, 177
 SORTED REPORT screen, 37, 107, 109, 111
 Sorted reports, defining, 107-108
 Special function window, 12-13
 Special function key label, 12-13
 Special function key identifier, 12-13
 Starting forms creation, 30-34
 Stop between pages default, 118, 124,
 142, 147
 Storage of file records, 10
 Storing formats, 115
 Labels, 158

Letters, 150
 Reports, 115
 Subtotals, 114
 Diagrams, 110, 113

Fields for, 44
 Requirements for, 112
 Summary, SEARCH screen, 86-88

T

Tabs, setting, 65-67
 Terms, definition of, 7
 Text, 49, 104
 Changes on master form, 171
 Labels, 154, 164
 Letters, 132-133
 Reports, 104
 Title/feedback window, 12-13
 TO field, 56
 TOTAL AMOUNT PAST DUE field, 56,
 70-72, 101-102, 123-124
 Trends, report, 112
 Averages, 115

CLIENTS file, 124
 Grand totals, 114
 Minimum/maximum values, 115
 Subtotals, 114
 Types, field, 39-40
 Autodate, 42
 Character, 40
 Currency, 41-42
 Date, 42-43
 Float, 41
 Formatted character, 46-47
 Integer, 40-41
 Types, output format, 91, 94

U

UNDO, use of, 85
 Unformatted character fields
 See Character fields
 UNLOAD screen, 183-184, 189
 UPDATE screen, 80-84
 Updating records, 80-83

Duplicate keys, 84
 Editing fields, 80
 Procedure, 81-83
 Use of manual, 11
 Using backup files, 190

V

Valid format changes, 117

Verifying MSUSs, 60-61

W

Width (label), 152
 Width, report, 96

Wild card searches, 73, 76-77
 Windows, 12-13

XYZ

YTD BUSINESS VOLUME field, 41-42, 56,
 67, 75-76, 101-102, 123-124
 YTD CONSULTING HOURS field, 40-41, 56,
 123-124

ZIP CODE field, 46, 50-51, 56, 78-79, 139,
 146-147, 158, 165